

Circumference Welding Machine

▶▶ **CW-350R/CW-600R**



CW-600R

Features

- Full digital & PLC control support flexible welding process setting and multiple programmable welding sequences edit.
- The system includes alarm history, alarm messages and PLC I/O monitoring functions.
- Tilt style main frame design that allows 7 angular position adjustment from vertical to horizontal position (0~90°).
- Multi-function welding bracket assembly for all position special welding job demand.
- 75 mm stroke adjustable pneumatic clamping of tailstock and movement on high precision linear guide way.
- TA-100 pneumatic torch actuator with 100 mm stroke to control and ensure welding torch positioning at high accuracy.
- Welding table equipped with low backlash precision reducer and include 22 mm diameter through-hole for gas purge.
- Allows for input voltage hookup 100~240V AC without manual linking.
- All units are high frequency protected.

Specifications

Full Digital Control

The system employs PLC controller together with 5.6 inches, full color TFT touch screen HMI. A closed loop driver system is also included to maintain the constant rotation speed and increase accuracy, stability and efficiency.

Flexible Welding Process Setting

Configurable continuous welding angle from 0~1,800 degree and turn table RPM. Configurable work piece diameter, travel distance (max. 5 turns) and linear speed. Graphical welding sequence and 10 configurable timers allow easy and flexible operation.

Multiple Programmable Welding Sequences

100 sets of welding sequence can be saved and loaded for future use. Saving content may include: file name, turn table position, rotation speed, sequence timer setting and motor parameters (offset and gain).

The search function also enables the user to have quick access to the particular welding sequences.

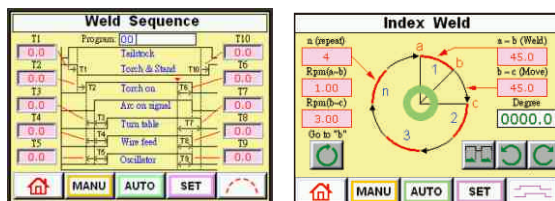

Maintenance Function

The system includes alarm history, alarm messages and PLC I/O monitoring functions, which facilitates troubleshooting and maintenance and increases overall production efficiency.

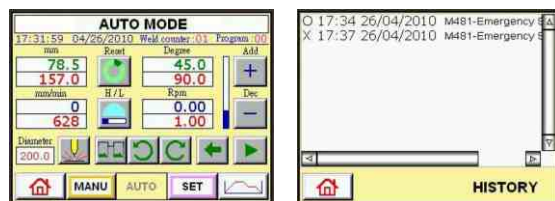

Model	Unit	CW-350R	CW-600R
Power input		AC 110~240V, 50/60 Hz, 1 phase	
Rotation motor	hp	1/12	
Overall length (A)	mm	870	975
Overall width (B)	mm	795	
Overall height (C)	mm	1,450	
Center to floor	mm	~	
Part weight capacity	kg	130	
Part diameter	mm	350	600
Part length (D)	mm	600	
Welding equipment capacity	kg	10	
Tailstock stroke (E)	mm	75	
Table diameter (F)	mm	Ø320	
Table pilot hole	mm	Ø22	
Table slot bolt size		M10	
Rotation speed	rpm	0.15 ~ 16* ¹	
Earthing	Amp	300A 100%	
Weight	kg	175	190

*1 A:0.15~4 B:0.3~8 C:0.4~12 D:0.55~16

*Specifications subject to change without notice

Dimensions

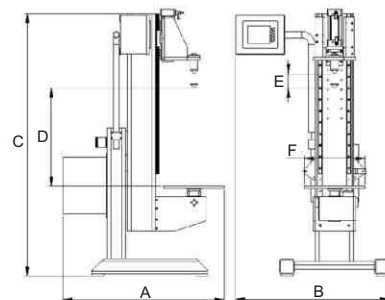

Options

- Welding grounds
- Grippers

UNITED PROARC CORPORATION

No.3, Gungye 10th Road, Pingjen Ind. Park, Pingjen Dist, Taoyuan City 32459, Taiwan
 Tel: 886-3-4696600 Fax: 886-3-4694499 http://www.proarc.com.tw E-mail:sales@proarc.com.tw