

# SPIROL<sup>®</sup>

## ALIGNMENT DOWELS/BUSHINGS



**SPIROL's** roll formed hardened Bushings are designed to meet one or more of the following objectives:

- ⊙ **Align mating components,**
- ⊙ **Eliminate drilling of a separate bolt hole,**
- ⊙ **Protect bolts from shear loading, and/or**
- ⊙ **Maintain joint integrity**

Although these hollow, lightweight Bushings are not precision ground and do not require precision holes, thus saving in component and hole preparation costs, they are capable of precision alignment if the design guidelines are followed. Further savings can be achieved by using the inside of the Bushing for the bolt and thus eliminating the cost of a separate bolt hole. This design concept also protects the bolt from shear loads perpendicular to the bolt and isolates the forces on the bolt to tension loading. Shear forces acting on a bolted joint cause the joint members to slip back and forth, which causes the bolts and nuts to rotate, reducing the pre-load tension. This is particularly the case with short bolts with a reduced clamping distance.



# SPIROL® Product Features and Benefits

## SPRING ACTION

The diameter of the Bushing is slightly larger than the hole. The spring action of the Bushing allows it to be installed into a drilled or cored hole and assume the diameter of the hole. It is self-retained once installed.

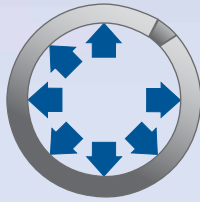

## STAGGERED SEAM

The staggered seam prevents interlocking, making these Bushings suitable for automatic feeding and eliminating the need to separate them during manual assembly.

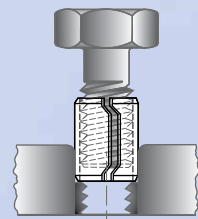
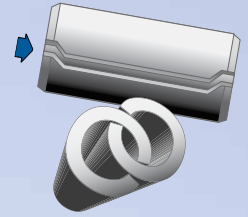

## CONTROLLED INSIDE DIAMETER

The inside diameter of the Dowel Bushings is designed to provide clearance for a bolt through the Bushing for the purpose of fastening the aligned components together. This isolates the bolt from the shear loading and increases the joint integrity. It also eliminates the cost of a separate hole.

## LEAD-IN CHAMFERS

The beveled chamfer around the entire periphery of the Bushing is designed to facilitate ease of insertion and to avoid skiving of the Bushing during installation.

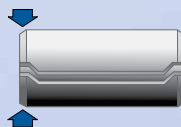



**Dowel Bushings** are used to locate components in conjunction with bolts which pass through the inside of the Dowel after it has been installed. Separate holes for locating pins are eliminated. The hardened Dowels also absorb shear loads, isolating the bolts from these forces.

### Series DB100

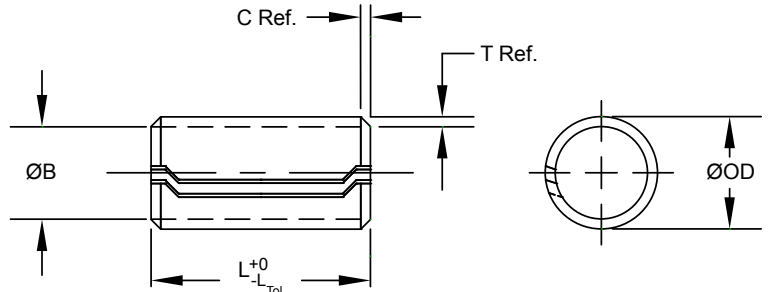

#### MATERIAL

**B** High Carbon Steel

#### FINISH

**K** Plain, Oiled

#### DIMENSIONAL DATA

Metric									
Nominal Bolt Diameter	Min. ØID Installed <sup>1</sup>	ØOD		Wall Thickness T	Chamfer		Recommended Ø Hole Size		Min. Single Shear (kN) <sup>2</sup>
		Min.	Max.		C Length	ØB Max.	Min.	Max.	
6	6.20	7.92	8.18	0.70	1.40	7.50	7.67	7.80	10.9
8	8.20	10.35	10.61	0.90	1.40	9.85	10.10	10.23	18.7
10	10.20	12.75	13.01	1.10	1.40	12.20	12.50	12.63	28.4
12	12.25	15.50	15.76	1.45	1.80	14.85	15.25	15.38	45.4
16	16.25	20.25	20.51	1.80	1.80	19.50	20.00	20.13	74.6

Inch									
Nominal Bolt Diameter	Min. ØID Installed <sup>1</sup>	ØOD		Wall Thickness T	Chamfer		Recommended Ø Hole Size		Min. Single Shear (lbs.) <sup>2</sup>
		Min.	Max.		C Length	ØB Max.	Min.	Max.	
.250   1/4	.256	.325	.335	.028	.050	.308	.315	.320	2,500
.312   5/16	.318	.401	.411	.035	.050	.381	.391	.396	4,000
.375   3/8	.381	.479	.489	.042	.050	.457	.469	.474	5,750
.500   1/2	.510	.640	.650	.057	.060	.615	.630	.635	10,500

Nominal Bolt Diameter	Metric Length					
	12	15	20	25	30	35
6						
8			LENGTH TOLERANCE + 0.0mm - 1.0mm			
10						
12						
16						

Nominal Bolt Diameter	Inch Length			
	.500 1/2	.750 3/4	1.000 1	1.250 1-1/4
.250   1/4				
.312   5/16		LENGTH TOLERANCE +.000" -.030"		
.375   3/8				
.500   1/2				

<sup>1</sup> When installed in recommended hole.

<sup>2</sup> Single shear minimum, tested in accordance with ISO 8749 and ASME B18.8.2 Appendix B.

Testing can only be performed on Dowels greater than two diameters in length.

- On special order plated parts, all dimensions apply prior to plating.
- Special lengths and sizes available upon request.

**To Order:** BUSH, Nominal Dowel Size x Length, Material, Finish, Series  
**Example:** BUSH 10 x 25 BK DB100



**Spring Dowels** are used to accurately locate components with respect to each other. They are formed around arbors to assure roundness. It is recommended that one half the hole tolerance be used for the fixed location of the Dowel and one half for the hole in the mating part.

### Series SD200

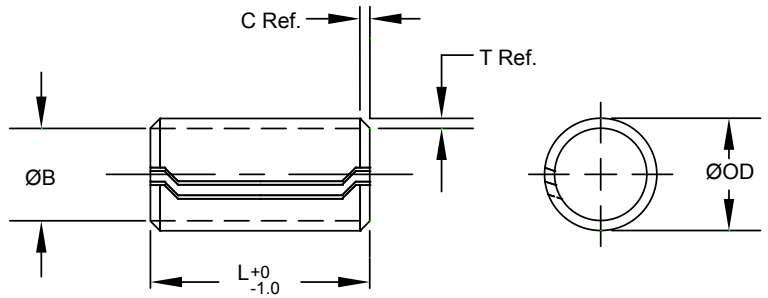

#### MATERIAL

**B** High Carbon Steel

#### FINISH

**K** Plain, Oiled

#### DIMENSIONAL DATA

Metric								
Nominal Dowel Diameter	ØOD		Wall Thickness <b>T</b>	Chamfer		Recommended Ø Hole Size		Min. Single Shear (kN) <sup>1</sup>
	Min.	Max.		C Length	ØB Max.	Min.	Max.	
6	6.25	6.50	0.55	1.00	5.85	6.00	6.13	6.6
8	8.25	8.50	0.70	1.40	7.80	8.00	8.13	11.5
10	10.25	10.50	0.90	1.40	9.75	10.00	10.13	18.5
12	12.25	12.50	1.10	1.40	11.70	12.00	12.13	27.1

Metric					
Nominal Dowel Diameter	Length				
	12	15	20	25	30
6					
8					
10					
12					

<sup>1</sup> Single shear minimum, tested in accordance with ISO 8749. Testing can only be performed on Dowels greater than two diameters in length.

- On special order plated parts, all dimensions apply prior to plating.
- Special lengths and sizes available upon request.
- Inch sizes available upon request.

**To Order:** BUSH, Nominal Dowel Size x Length, Material, Finish, Series  
**Example:** BUSH 8 x 20 BK SD200



## Doweling for Permanent Positioning

If components are located or positioned by methods other than the Doweling itself, and the issue is to allow for disassembly and then re-assembly with the components in exactly the same location – then it is recommended that the components be drilled together and the Dowel installed in the assembled condition. During disassembly, the Dowel may be removed and reinstalled during re-assembly. This method eliminates the need for hole tolerancing and hole centerline concerns. It provides for very accurate permanent locating.

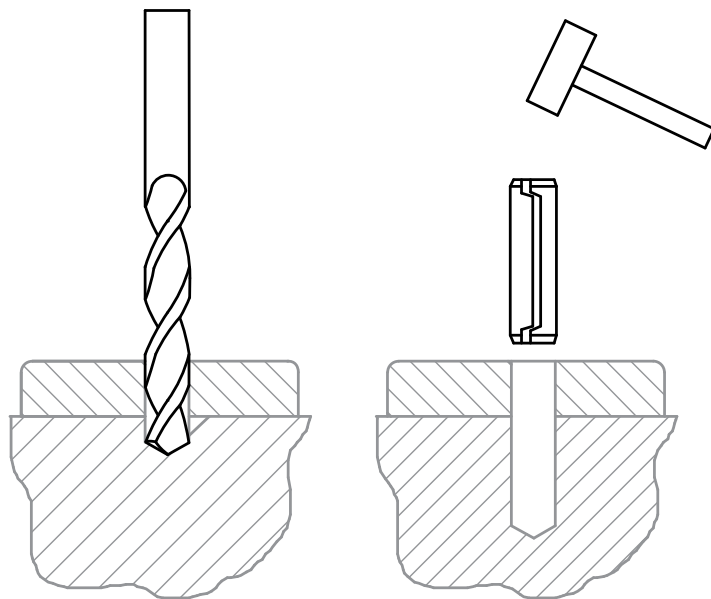

## Doweling to Fix Relative Location Of Components

The more common application is to use the Dowels to fix the relative location of two or more components. In this situation, the Dowels are partially installed in one component, the initial installation, and then holes in the mating component are pushed over the exposed end of the partially installed Dowel. The following factors need to be considered for precision location:

- ⦿ Hole dimension tolerance
- ⦿ Relative depth of initial installation
- ⦿ Total length of the Bushing
- ⦿ True position of hole centerlines

These factors are interrelated and need to be considered together. The following general guidelines are helpful in determining the best design in a specific situation.

- ⦿ Precise holes with reduced hole tolerances increase the cost but also increase location accuracy and simplify the design considerations.
- ⦿ Wider hole tolerances require longer Dowels to assure a tight, non clearance fit in both components.
- ⦿ Hole tolerance should be minus in the initial installation hole and plus in the mating component hole.
- ⦿ The maximum hole tolerance should not exceed one half (1/2) of the recommended tolerance range to allow for hole tolerancing of both holes within the tolerance range.
- ⦿ Fixing the Dowel location in a through hole can be achieved through length of engagement and hole tolerancing, or both. Generally, an engagement of 60% of the total length in the smaller hole is recommended for the fixed location.
- ⦿ If more than one Dowel is used, holes in the upper recommended tolerance range allow for a wider tolerance in centerline location.

### Precise Holes

If the holes are precise and the same in both components, such as honed or reamed holes with a tolerance of .0008" or 0.02mm, then the length of the Bushing need only receive minor consideration for purposes of precise relative location. We recommend using the minimum specified hole in these situations. The Bushing will assume the diameter of the initial installation hole and the unsized diameter of the normally exposed end would compensate for the tolerance difference between the holes if any. If no interference whatsoever is acceptable when assembling the mating component over the exposed Bushing, then it is recommended to keep the exposed Dowel length to a minimum, or if practical, to push the Dowel through the initial component to size the exposed end. In any event it is recommended to install at least two thirds of the total Dowel length into the initial hole so as to permanently fix the Dowel position.

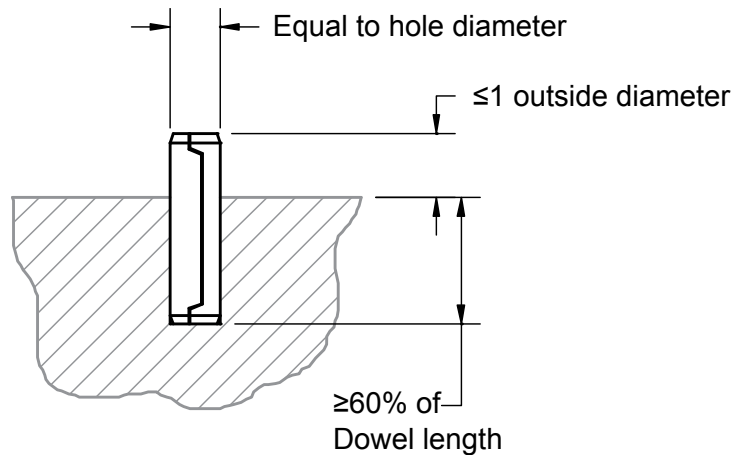

### Maximum Tolerance Holes

The maximum allowable tolerance is one-half the total recommended tolerance. This is still within the normal production hole tolerance for drilled or cored holes. The smaller hole, that is the hole with the minus tolerance, should be the hole into which the Dowel is initially installed. The larger hole, that is the hole in the mating component, should have a plus tolerance. To illustrate: The total recommended hole tolerance for an  $\varnothing 8$ mm Dowel is  $\varnothing 8.00$  to  $\varnothing 8.13$ mm. Take the approximate midpoint and split the tolerance. The smaller hole would be  $\varnothing 8.00$  to  $\varnothing 8.06$ mm, the larger  $\varnothing 8.06$  to  $\varnothing 8.13$ mm. The smaller hole used for the initial installation will size the Dowel but the protruding unsized length of the Dowel remains larger, with the diameter increasing as the distance from the hole increases. It normally requires a protruding length equal to 1-1/2 times the Dowel diameter for a Dowel installed in a minimum hole to have a protruding diameter greater than the maximum hole. For an  $\varnothing 8$ mm Dowel in a  $\varnothing 8$ mm hole, that would require a protrusion of 12mm to have a Dowel diameter at the protruding end greater than  $\varnothing 8.13$ mm. The smaller hole in the initial installation helps in fixing the location of the Dowel but it is still recommended that the greater length of engagement be in the smaller initial hole. Therefore, in the example used here to illustrate the maximum hole tolerance situation, the Dowel would be BUSH 8 x 30 BK SD 200.

Total hole tolerance =  $\varnothing 8.00$  to  $\varnothing 8.13$ mm  
 Hole for fixed Dowel location =  $\varnothing 8.00$  to  $\varnothing 8.06$ mm  
 Mating component hole =  $\varnothing 8.06$  to  $\varnothing 8.13$ mm

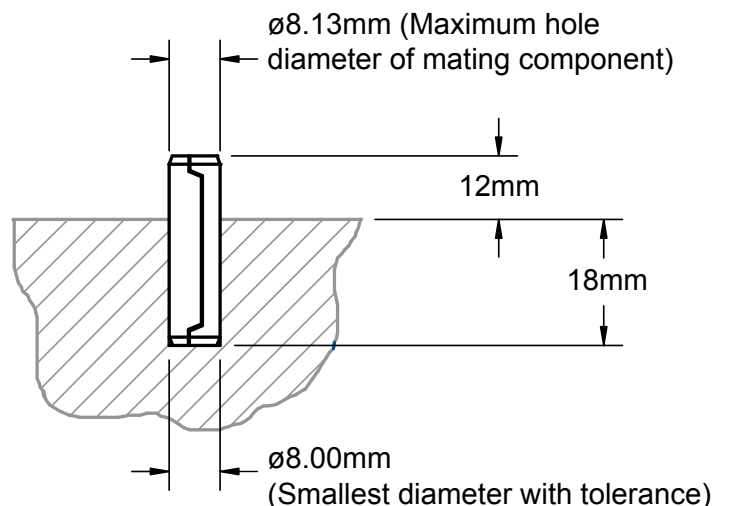

### Centerline Tolerancing

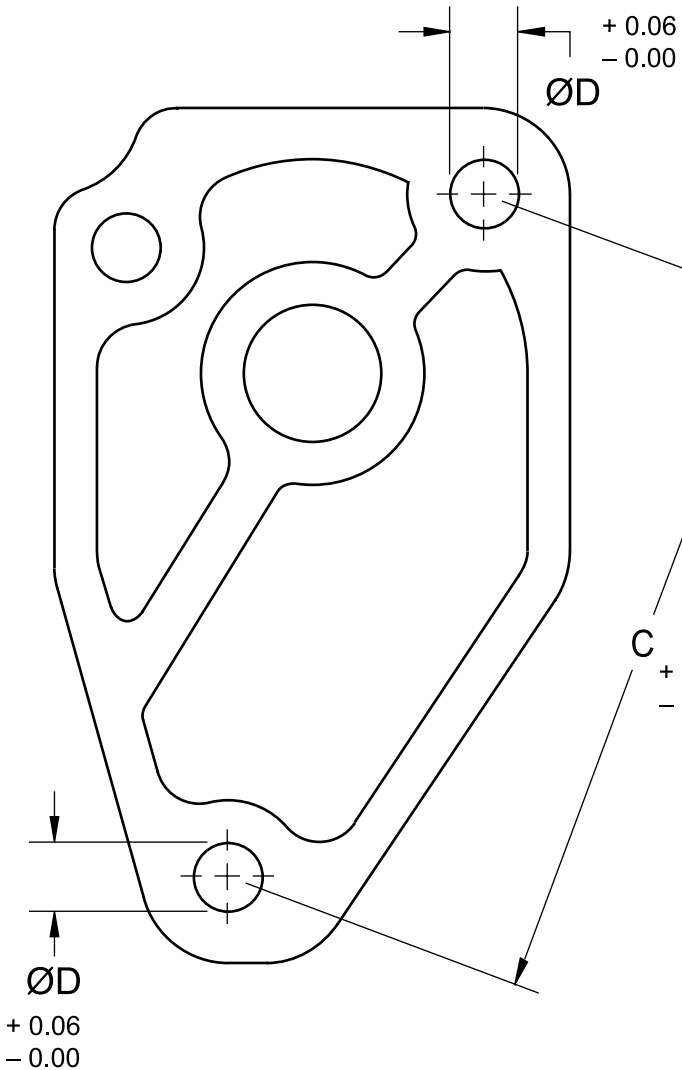

If more than one Dowel is used, centerline tolerancing for hole positioning becomes an issue. In situations with precision holes requiring precision locating, the centerline tolerancing needs to be accurate and similar to tolerancing used for solid Dowels. A tolerance of .0006" or 0.015 mm is recommended. When a Dowel is installed in a minimum hole, which is recommended in these cases, the Dowel gap is butted and further spring action is very limited, if any.

Hole tolerance can be increased to provide for relaxed positioning tolerances with some sacrifice of rigidity. The centerline tolerance can be increased to the tolerance of the holes, or the smallest tolerance if the tolerances of the holes are different. In the  $\text{Ø}8\text{mm}$  Dowel example used, the centerline tolerance can be 0.06mm. The net hole at maximum misalignment cannot be less than the smallest recommended hole; in the example,  $\text{Ø}8\text{mm}$ . The misalignment will normally distribute itself between the Dowels.

If it is a Dowel Bushing application with a bolt passing through the Dowel into a threaded component, the clearance between the minimum inside diameter of the Dowel Bushing and maximum bolt diameter needs to be enough to compensate for misalignment. If these guidelines are used, the standard clearance will always be adequate at maximum misalignment.

### Blind Holes and Stepped Holes

Blind and stepped holes can be used for Dowel location and stepped holes are generally used for Dowel Bushings used in conjunction with bolts. Since blind and stepped holes only fix the Dowel location in one direction, it is still recommended that the Dowel be fixed into location by using the smaller hole and greater length of engagement.

### Joint Integrity

Loss of joint integrity due to rotational loosening is triggered by vibration. Loads perpendicular to the axis of the bolt, particularly cyclic loading cause slip at the bolt head or the nut which translates into rotational loosening. Dowels, particularly Dowel Bushings, reduce or even eliminate rotational loosening. In this instance, the use of the smallest hole possible within the tolerance range is recommended to reduce Dowel flexibility after insertion. The shear strength also needs review. In static loading or a long cycle time between loads, maximum load should not exceed of 75% of the minimum shear strength. When the loads are in the form of severe vibration, 50% is recommended.

**SPIROL APPLICATION SPECIALISTS ARE AVAILABLE  
TO MAKE RECOMMENDATIONS BASED ON YOUR REQUIREMENT  
OR TO REVIEW YOUR APPLICATION.**



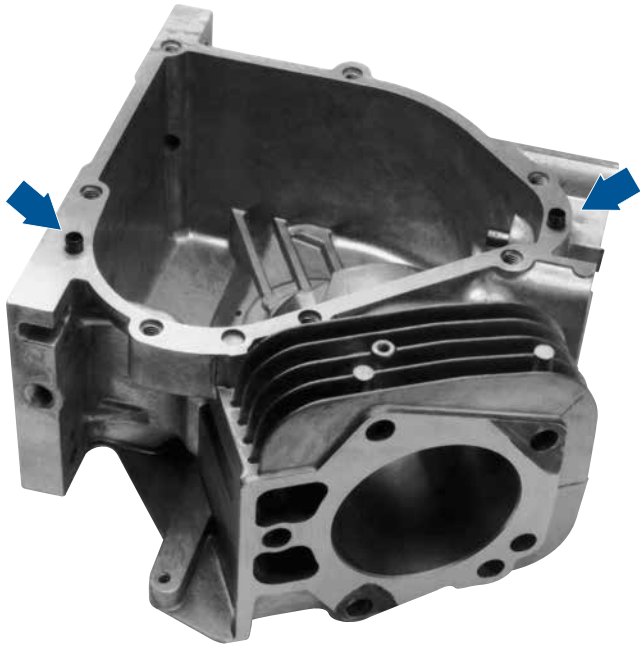

ENGINE HOUSING

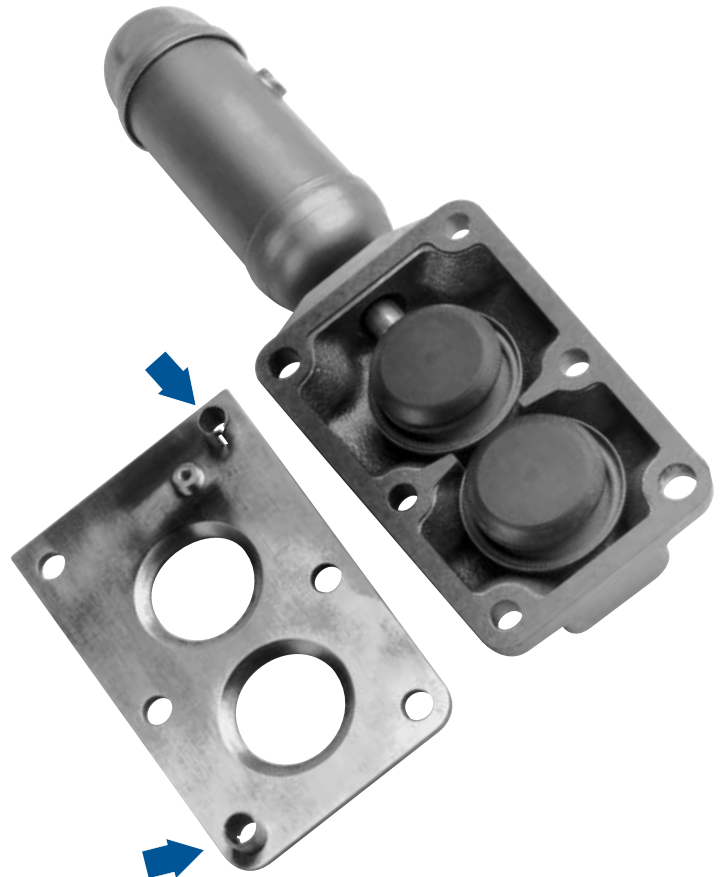

SWITCH HOUSING ASSEMBLY

ENGINE CAM SHAFT CAPS

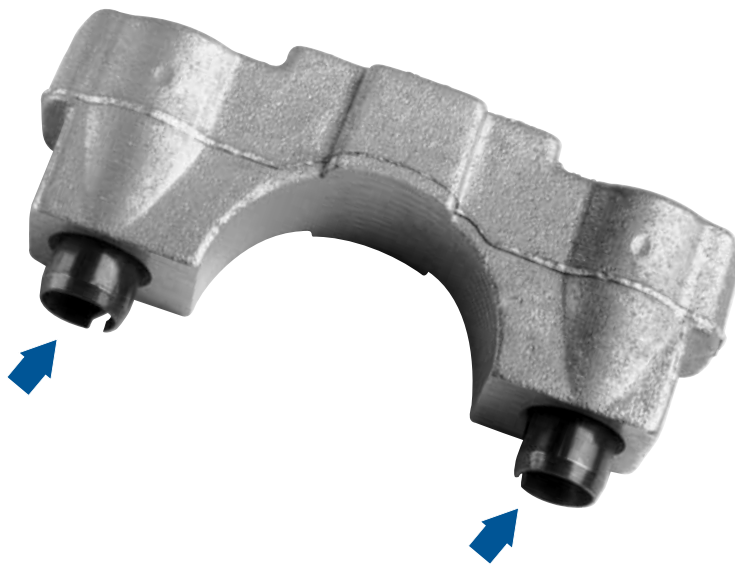

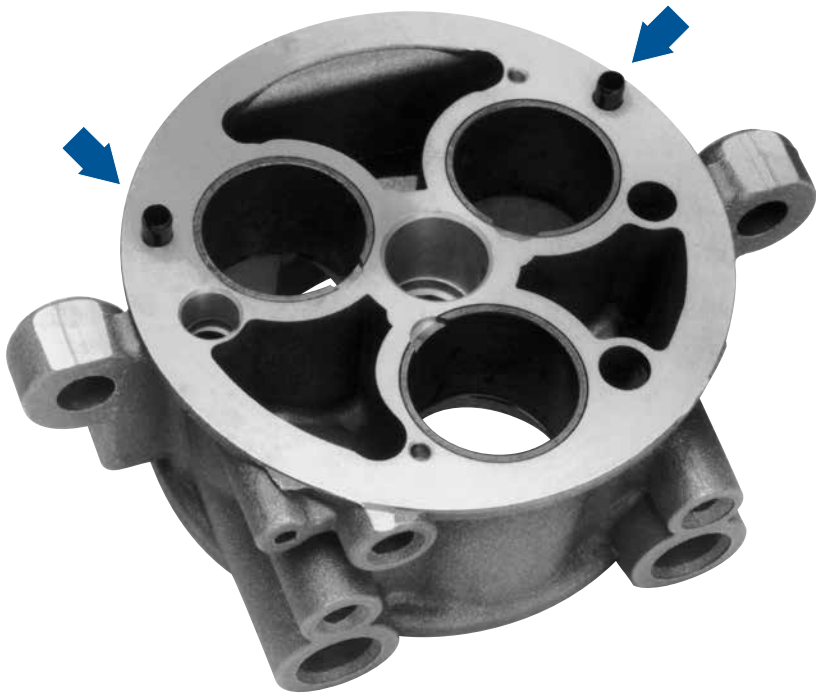

VALVE

INTAKE MANIFOLD HOUSING

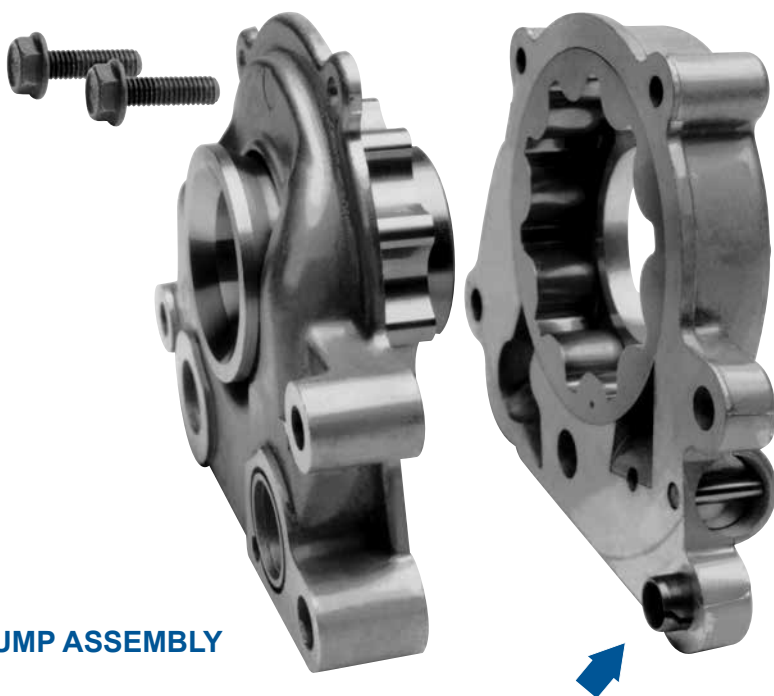
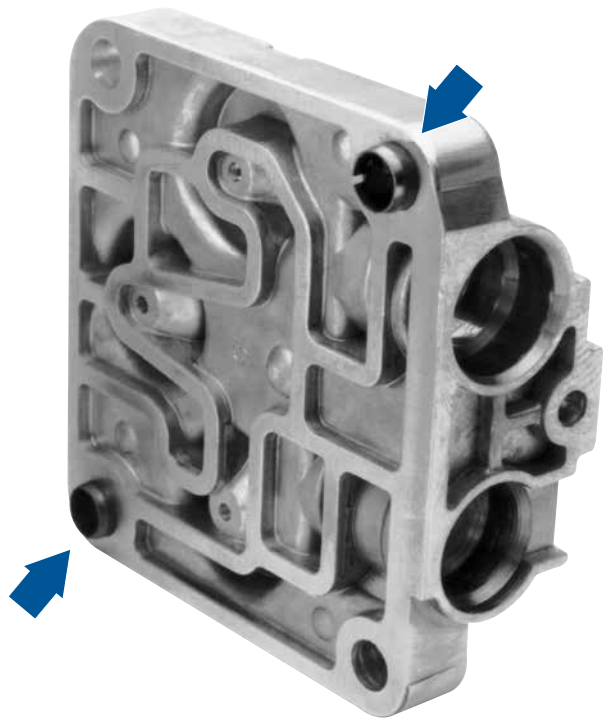

OIL PUMP ASSEMBLY

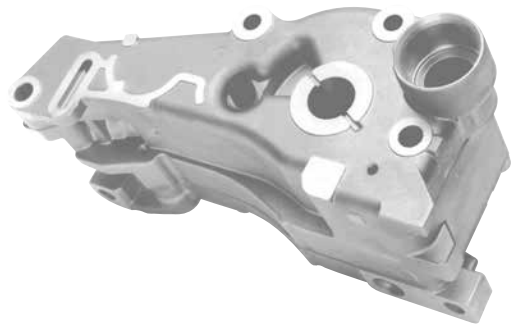

OIL PUMP HOUSING

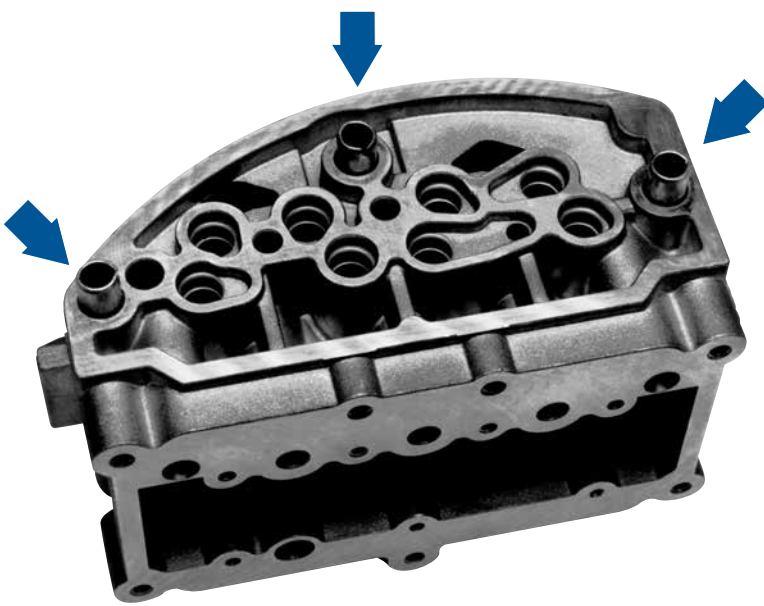
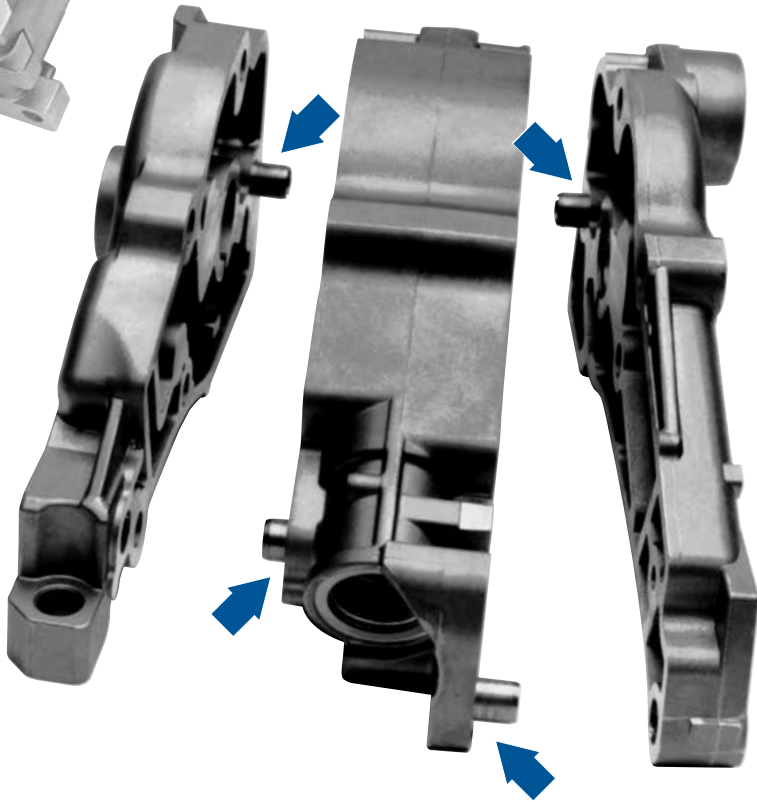
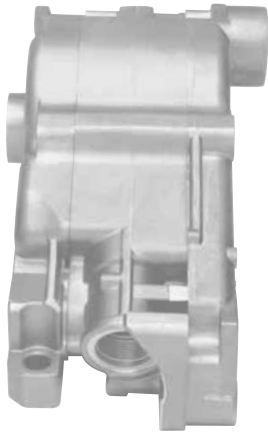

TRANSMISSION SOLENOID HOUSING



## Technical Centres

**Europe** **SPIROL United Kingdom**  
17 Princewood Road  
Corby, Northants  
NN17 4ET United Kingdom  
Tel. +44 1536 444800  
Fax. +44 1536 203415

**SPIROL France**  
Cité de l'Automobile ZAC Croix Blandin  
18 Rue Léna Bernstein  
51100 Reims, France  
Tel. +33 3 26 36 31 42  
Fax. +33 3 26 09 19 76

**SPIROL Germany**  
Ottostr. 4  
80333 Munich, Germany  
Tel. +49 89 4 111 905 71  
Fax. +49 89 4 111 905 72

**SPIROL Spain**  
08940 Cornellà de Llobregat  
Barcelona, Spain  
Tel. +34 93 193 05 32  
Fax. +34 93 193 25 43

**SPIROL Czech Republic**  
Sokola Tůmy 743/16  
Ostrava-Mariánské Hory 70900  
Czech Republic  
Tel/Fax. +420 417 537 979

**SPIROL Poland**  
ul. Solec 38 lok. 10  
00-394, Warszawa, Poland  
Tel. +48 71 399 44 55

**Americas** **SPIROL International Corporation**  
30 Rock Avenue  
Danielson, Connecticut 06239 U.S.A.  
Tel. +1 860 774 8571  
Fax. +1 860 774 2048

**SPIROL Shim Division**  
321 Remington Road  
Stow, Ohio 44224 U.S.A.  
Tel. +1 330 920 3655  
Fax. +1 330 920 3659

**SPIROL Canada**  
3103 St. Etienne Boulevard  
Windsor, Ontario N8W 5B1 Canada  
Tel. +1 519 974 3334  
Fax. +1 519 974 6550

**SPIROL Mexico**  
Avenida Avante #250  
Parque Industrial Avante Apodaca  
Apodaca, N.L. 66607 Mexico  
Tel. +52 81 8385 4390  
Fax. +52 81 8385 4391

**SPIROL Brazil**  
Rua Mafalda Barnabé Soliane, 134  
Comercial Vitória Martini, Distrito Industrial  
CEP 13347-610, Indaiatuba, SP, Brazil  
Tel. +55 19 3936 2701  
Fax. +55 19 3936 7121

**Asia Pacific** **SPIROL Asia Headquarters**  
1st Floor, Building 22, Plot D9, District D  
No. 122 HeDan Road  
Wai Gao Qiao Free Trade Zone  
Shanghai, China 200131  
Tel. +86 21 5046 1451  
Fax. +86 21 5046 1540

**SPIROL Korea**  
160-5 Seokchon-Dong  
Songpa-gu, Seoul, 138-844, Korea  
Tel. +86 21 5046-1451  
Fax. +86 21 5046-1540

email: [info-uk@spirol.com](mailto:info-uk@spirol.com)



Please refer to [www.SPIROL.co.uk](http://www.SPIROL.co.uk) for current specifications and standard product offerings.

**SPIROL** Application Engineers will review your application needs and work with you to recommend the optimum solution. One way to start the process is to visit our **Optimal Application Engineering** portal at [SPIROL.co.uk](http://SPIROL.co.uk).