

# DSS 1064-450

Diode pumped passively Q-switched solid state laser

- 1064 nm
- single pulse
- < 1.7 ns
- 1 – 100 Hz
- > 450  $\mu$ J

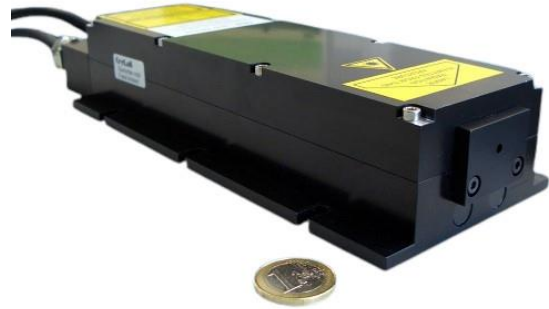

## biology · biomedicine · chemistry · analytics

<b>Optical Data</b>	Wavelength	1064 nm
	Spatial Mode	TEM <sub>00</sub>
	M <sup>2</sup>	< 1.5
	Beam Divergence (full angle)	< 6.5 mrad
	Beam Ellipticity	< 2:1
	Waist Diameter	380 ± 100 $\mu$ m (located at about 110mm inside the laser head)
	Beam Diameter	650 ± 150 $\mu$ m (at laser exit)
	Peak Power	> 250 kW @ 1 - 100 Hz
	Pulse Energy	> 450 $\mu$ J @ 1 - 100 Hz
	Pulse Repetition Rate (with external trigger)	1 - 100 Hz
	Pulse Width (FWHM)	< 1.7 ns
	Polarization Ratio	> 100:1, vertical
	Long term pulse energy stability (6 hours) <sup>1)</sup>	< ± 6 %
	Pulse-To-Pulse Stability <sup>2)</sup>	< 1 % rms
Laser Classification	3B / IIIb	
<b>Optical Output</b>	Free Beam	
<b>Electrical Data</b>	Electrical Power Consumption	< 70 W
	Line Voltage	100 - 240 V AC (50-60 Hz) or 24 V DC
<b>Interface</b>	RS 232, USB	
<b>Miscellaneous</b>	Warm-up Time	< 15 min
	Operating Temperature	18 - 38 °C
	Laser Head Size	217 x 65 x 45 mm (core dimensions)
<b>Options</b>	SMA-connector for fiber with core diameter $\geq$ 200 $\mu$ m	
	Synchronization signal output (rise time < 2 ns)	
	Manual shutter or electrical beam blocker	
	Other repetition rates on request	
	External telescope (e.g. M=5)	
	Manual or electrical attenuator	
	Stand Alone System (incl. key-switch, heat sink, manual shutter; CDRH compliant)	

<sup>1)</sup> Drift over 6 hours, energy averaged over 10 sec after 5 min of continuous operation, temperature variation < 3 °C/hour.

<sup>2)</sup> RMS over 1000 pulses after 5 min of continuous operation.

# Laser Head and Controller

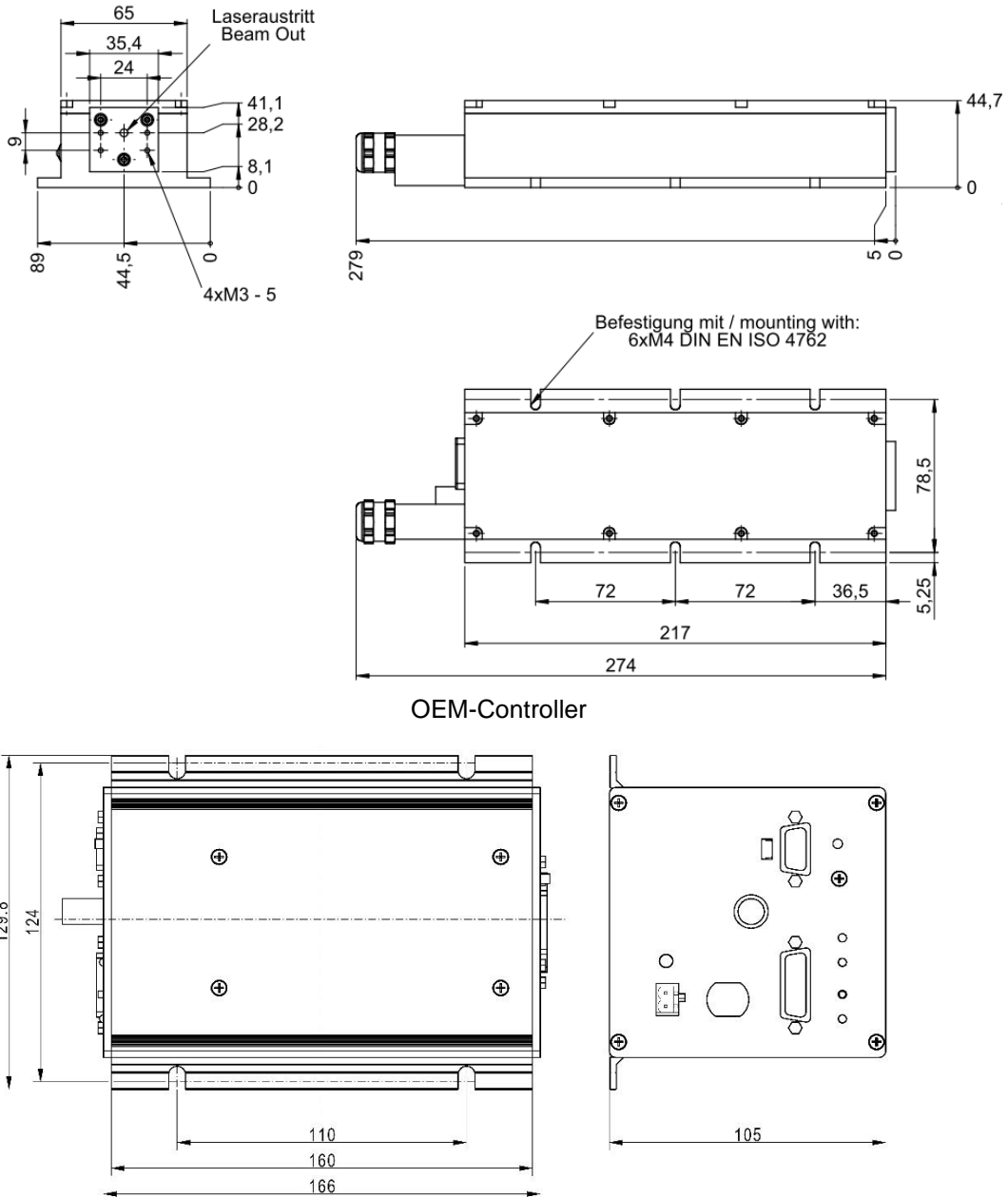

OEM-Controller

## Laser Safety Labels

The DSS1064-450 lasers are class 3B / IIIb according to IEC 60825-1:2014

<p>wavelength: 1064 nm  max. output: 1 mJ  pulse duration: &lt;2 ns  max. repetition rate: 200 Hz</p> <p>Complies with IEC 60825-1:2014  Complies with 21CFR 1040.10 and 1040.11  except for deviations pursuant to  Laser Notice No. 50, dated July 26, 2001</p>	<p><b>WARNING - INVISIBLE  LASER RADIATION  AVOID EXPOSURE  TO BEAM</b></p> <p><b>CLASS 3B  LASER PRODUCT</b></p>	<p>IS EMITTED FROM THIS  APERTURE</p> <p>LASER  RADIATION</p>
---	---	---

