

# Torque Gauge – BTGE-G

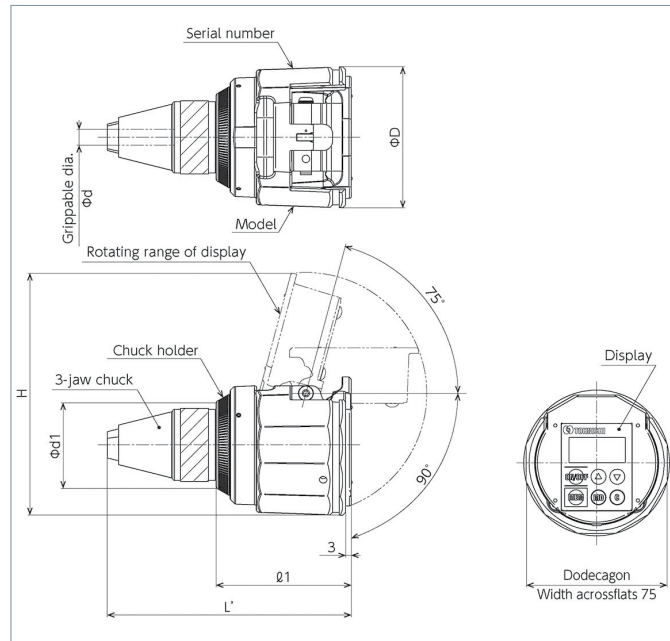

Img: BTGE10CN



- ▶ Accuracy  $\pm 2\% + 1$  digit.
- ▶ Bi-directional measuring – cw / ccw.
- ▶ Physical stopper prevents accidental over-loading.
- ▶ 999 readings can be saved with computing function for max/min/mean.
- ▶ Coin-type lithium battery allows 10-hour continuous operation.
- ▶ 4 selectable torque units: cN-m, kgf-cm, ozf-in, lbf-in.
- ▶ Applicable for international use including the EU region. Compliant with CE and RoHS directives.

## Digital Torque Gauge with flip-up LC-Display

High precision handheld digital torque gauge with integrated LC display to measure small torque. Ideal for torque measurement on precision machinery, electronic devices, and various assembly components. Flip-up display can be adjusted for optimal reading and accommodates various testing positions.

BTGE-G series products are manufactured for the global market and offer a selection of SI, metric and American units of measurement. Equipped with SI calibration as standard, optionally available with calibration in english (ozf-in, lbf-in) or in metric (kgf-cm) units.

There are various application types, even for measuring rotating objects. Combined with Measurement Board (#809), it can be fixed to use as torque screwdriver checker, et al.

Delivery in firm storage case including traceable calibration certificate, operating manual and Lithium battery CR2450.

Optional USB cable can be used for data transfer to PC (free Data Receiver Software available\*).

### Optional Accessories

INFO

- Measurement stand #809.
- Battery pack #BP-C1 for up to 50 hours continuous use.
- USB cable #384, Data Receiver Software.\*
- AC adaptor #BA-5 (requires cable #384).
- Calibration Kit #BTGTCL150CN.

### BTGE-G

Model	Item No.	Torque Range						Dimensions		Chuck span mm	Weight kg
		cN-m		ozf-in		lbf-in		L' mm	øD mm		
		Min - Max	1 Digit	Min - Max	1 Digit	Min - Max	1 Digit				
BTGE10CN-G	T251120	2 - 10	0.01	3 - 14	0.01	0.2 - 0.88	0.001	130	75	1 - 8.5	0.65
BTGE20CN-G	T251121	4 - 20	0.02	6 - 28	0.02	0.4 - 1.7	0.002	130	75	1 - 8.5	0.65
BTGE50CN-G	T251122	10 - 50	0.05	15 - 70	0.05	1 - 4.4	0.005	130	75	1 - 8.5	0.65
BTGE100CN-G	T251123	20 - 100	0.1	30 - 140	0.1	2 - 8.8	0.01	130	75	1 - 8.5	0.65
BTGE200CN-G	T251124	40 - 200	0.1	60 - 280	0.2	4 - 17	0.02	130	75	1 - 8.5	0.65



Further information available on our website – 24/7.

\* Data Receiver software is a data input tool for Excel® data management. It can be downloaded for free. Note: Excel® is a registered trademark of Microsoft Corporation.