

# Limit Value Switch for Frequency Input Sinusoidal Signal

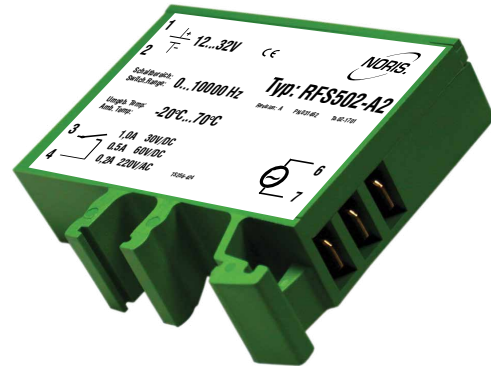

- Straightforward application
- Suitable for severe operating conditions
- Compact construction
- Limit value freely adjustable by drum scale
- Anti-tamper seal for drum scale
- Frequency ranges to suit customer requirements
- Provision made for fine adjustment of measuring range
- Meets high EMC-requirements
- Volt-free output as normally closed contact or normally open contact
- Open-circuit or closed-circuit variants available
- Open-circuit devices with integrated push button to simulate an increased sensor signal for test functions without critical machine loading
- Optionally with latching function (only open circuit devices)
- Operating characteristics displayed by integrated LEDs
- Flame-inhibiting and self-extinguishing body
- Suitable tachogenerators are available (NORIS devices GE...)



Limit Value Switch  
RFJ5.../RFS5.../RFG5...

## Limit Value Switch RFJ5.../RFS5.../RFG5...

### Method of Operation

Limit value switches of the series 5 are designed to monitor and process electric measured variables.

Working principle: When the actual value of the measuring signal supplied reaches the setpoint, the built-in relay will operate. The switching status of the relay contact may, for instance, be monitored or individually processed by a machine controller.

### Details

- Designed to monitor a sinusoidal frequency signal
- Suitable to evaluate outputs of speed pickups; AC-tachogenerators with various signal amplitudes
- Suitable to evaluate outputs of NORIS tachogenerators, GE...-series via RFG5...
- Factory-set maximum range frequency adjustment between 50 Hz and 10 kHz (maximum range frequency is 100 % of drum scale)
- Trimming potentiometer for re-adjustment of measuring range
- Limit value setpoint adjustable by means of drum scale from 5 ... 100 %
- Lowest limit value:  
50 Hz (RFx500...), 100 Hz (RFx501...), 1,000 Hz (RFx502...)

To avoid triggering errors the frequency full range set in factory must be the highest frequency of the measuring chain, the set point will be done in a ratio to the full range.

### Integrated Test Button for Test Purposes

Open-circuit devices have a test button integrated for testing purposes. As long as this button is kept pressed, the preselected limit value is decreased by approx. 15%. This enables safety functions, such as an overspeed trip to be tested without it being necessary to run the machine in the critical range.

### Volt-free Relay Contact, Closed-circuit or Open-circuit Version

A volt-free relay contact is provided as a normally closed or normally open contact for outputting and further processing. In addition, there is a choice between closed-circuit and open-circuit devices.

In the case of closed-circuit devices, the output relay is pulled up in the

normal state of operation with the operating voltage applied. It drops off upon the limit-value being exceeded or if the operating voltage fails. In the open-circuit variant, the output relay pulls up when the limit-value is exceeded with the operating voltage applied. Failure of the voltage will not result in any switching function below the limit value.

### Latching function for open circuit devices

Open circuit devices can optionally be equipped with a latching function (see type code). When the limit value is exceeded, the relay keeps activated even if the signal falls below the limit value afterwards. The device has to be reset by disconnecting the operating voltage.

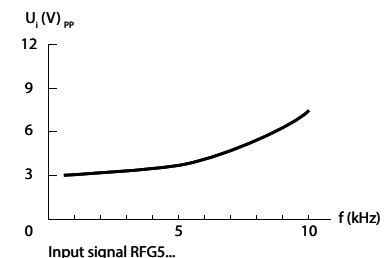
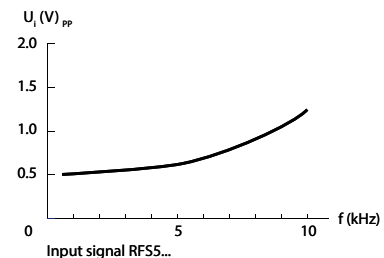
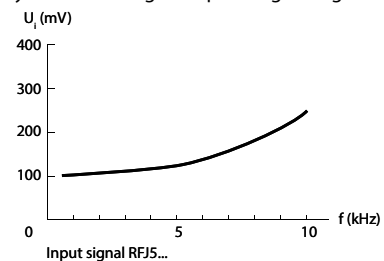

# Technical Data

Series RFJ5.../RF55.../RF55...		
Connection	Supply voltage	$U_s = 9 \dots 32 V_{DC}$ , $U_R = 24 V_{DC}$
	Ripple	$< 20\% U_o$
	Power consumption	Approx. 50 mA @ $24V_{DC}$
	Reverse voltage protection	Integrated
	Overvoltage	2.5 times $U_R$ up to 2 ms
	Voltage drops	100 % up to 10 ms
	Connection contact	DIN 46244: flat connector, gold-plated A6.3 x 0.8
Input	Galvanic isolation	Between input signal and supply voltage
	Input signal	Sinusoidal signal, NORIS tachogenerator GE
	Input overloading	RFJ5... up to 30 V, RF55... and RF55... up to 90 V
Output	Input resistance	RFJ5... approx. 10 k $\Omega$ , RF55... approx. 30 k $\Omega$ , RF55... approx. 15 k $\Omega$
	Output contact	Volt-free NOC or NCC, closed circuit or open circuit
Environmental influences	Max. switching capacity	30 W (1 A at $30 V_{DC}$ ; 0.5 A at $60 V_{DC}$ ); 40 W (0.2 A at $220 V_{AC}$ )
	Limit value	Adjustable on tamper-proof drum scale between 5 ... 100 %
	Operating temperature	-20 °C ... +70 °C
	Climatic test	DIN IEC 60068-T2-30
	Storage temperature	-45 °C ... +85 °C
	Vibration resistance	DIN IEC 60068-T2-6: 15 g increased strain, characteristic 2 (10 ... 100 Hz)
	Shock resistance (impact)	DIN IEC 60068-T2-27: 300 m/s <sup>2</sup> with 18 ms dwell time
	Degree of protection	DIN EN 60529: body IP20; terminals IP00
	ESD	IEC 61000-4-2: $\pm 8$ kV
	Electromagnetic field	IEC 61000-4-3: 10 V/m f=10 kHz ... 2.000 MHz, 80% AM @ 1 kHz 10 V/m f=900 $\pm$ 5 MHz, 50% AM @ 200 Hz 10 V/m f=1,800 MHz $\pm$ 5 MHz, 50% AM @ 200 Hz
	Burst	IEC 61000-4-4: $\pm 2$ kV supply; $\pm 1$ kV sensor
	Surge	IEC 61000-4-5: sym. $\pm 1$ kV ( $R_s=2 \Omega$ ); asym. $\pm 2$ kV ( $R_s=2 \Omega$ )
	HF-interference	IEC 61000-4-6: 3 V <sub>pp</sub> f=0.01 ... 100 MHz, 80% AM @ 1 kHz
	LF-interference	IEC 60553: 3 V <sub>pp</sub> 0.05 ... 10 kHz
	Interference field intensity	Basis CISPR 16-1, 16-2 reduced characteristic
Mech. quantities	Case material	Thermoplastic polyester, green
	Mounting	Snap-fit on G-channel TS32 or top-hat channel TS35
	Installation position	Any
Other	Weight	55 g
	Reproducibility	$< \pm 0.2\%$
	Linearity of scale	$< \pm 1.5\%$
	Hysteresis	Approx. 2% (1,5% for RFx502-devices)
	Test button function	Limit value lowered by approx. 15 % (only open-circuit devices)
	Accuracy class	IEC 51-1: 1.5 %
	Temperature sensitivity	$< \pm 0.1\%$ per 10 °K
	Voltage sensitivity	$< \pm 0.1\%$ for 10 % change in supply voltage
	Reaction time	f=50 Hz/0.25 s; f=100 Hz/0.2 s; f=1 kHz/0.1 s; f=10 kHz/50 ms
	Approvals	Approvals
Applied standards		DIN EN 61000-6-2, DIN EN 61000-6-4, DIN EN 50155
Fire protection class		V0

## Type Code

R **FJ** **5** **01** - **A2** (e. g. RFJ501-A2)  
 1 | 2 | 3 | 4 | 5

1	Device and series (Standard variants, other available on customer request)
	R Limit value switch
	2
2	Input signal
	FJ Frequency input for sinusoidal signal 100 mV <sub>pp</sub> ... 10 V <sub>pp</sub>
	FS Frequency input for sinusoidal signal 500 mV <sub>pp</sub> ... 30 V <sub>pp</sub>
3	Frequency input for sinusoidal signal 6 V <sub>pp</sub> ... 200 V <sub>pp</sub>
	4
	5

3	Type series
	5
	4
4	Input range $f_b$ /upper-range frequency $f_u$ /limit value $f_s$
	00 $f_b=10 \dots 100$ Hz; $f_u=50 \dots 100$ Hz; $f_s=50 \dots 100$ Hz mit $f_s \leq f_u$
	01 $f_b=20 \dots 1,000$ Hz; $f_u=100 \dots 1,000$ Hz; $f_s=100 \dots 1,000$ Hz mit $f_s \leq f_u$
5	Variant
	02 $f_b=200 \dots 10,000$ Hz; $f_u=1,000 \dots 10,000$ Hz; $f_s=1,000 \dots 10,000$ Hz mit $f_s \leq f_u$
	R1 Output contact as NCC in closed current
R2 Output contact as NOC in closed current	
A1 Output contact as NCC in open-circuit current	
A2 Output contact as NOC in open-circuit current	
S1 Output contact as NCC in open-circuit current with latching function	
S2 Output contact as NOC in open-circuit current with latching function	

# Dimensions, Connection, Diagram

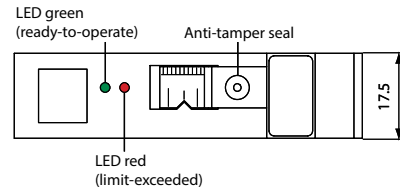
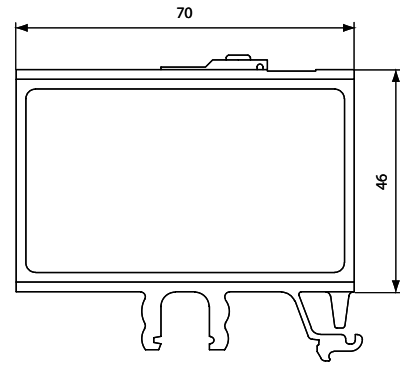

## G-channel TS32 to DIN EN 50035

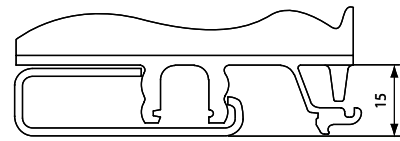

## Top-hat channel TS35 to DIN EN 50022

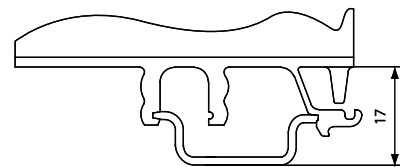

## Connection NCC RFx5...-...1

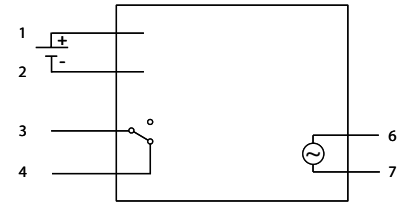

## Connection NOC RFx5...-...2

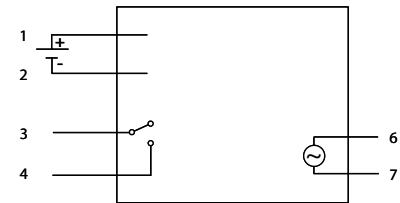

## Relais position

	RFx5...-R1	RFx5...-R2	RFx5...-A1	RFx5...-A2	RFx5...-S1	RFx5...-S2
f < limit value	-	x	x	-	x	-
f > limit value	x	-	-	x	- (*)	x (**)

x = contact closed  
 - = contact open  
 (\*) = Latching function: as -A2, but relay keeps open until  $U_s$  is disconnected  
 (\*\*) = Latching function: as -A2, but relay keeps closed until  $U_s$  is disconnected  
 The red LED is illuminated, if the limit value is exceeded

## Standard Variants

Frequency version	00	01	02
NCC in closed current	RFx500-R1	RFx501-R1	RFx502-R1
NOC in closed current	RFx500-R2	RFx501-R2	RFx502-R2
NCC in open-circuit current	RFx500-A1	RFx501-A1	RFx502-A1
NOC in open-circuit current	RFx500-A2	RFx501-A2	RFx502-A2

x is to be replaced with range J, S or G of input signal  
 Please state upper range frequency in case of order.

