

SPIROL[®]

INSERTS FOR PLASTICS

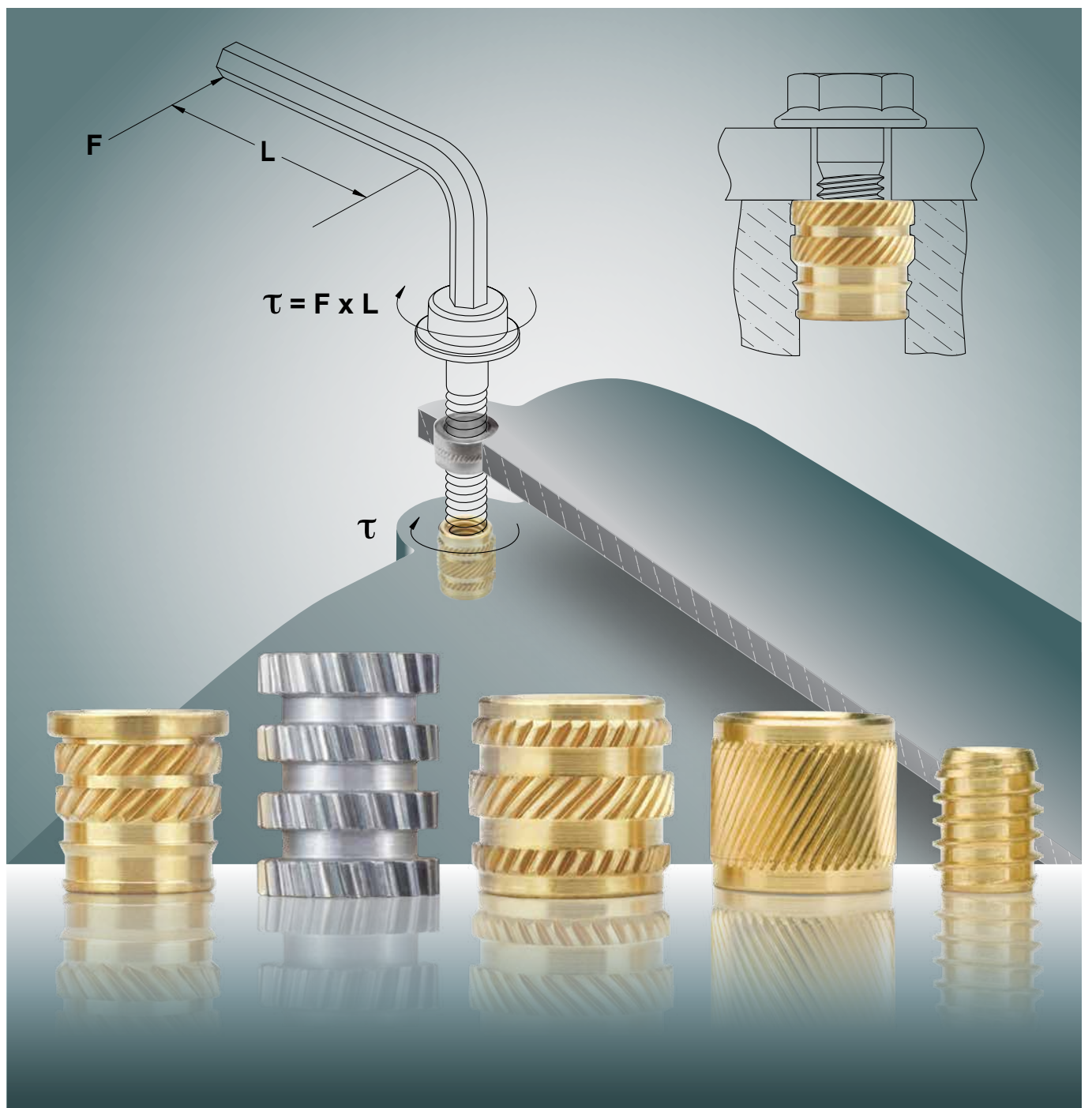

Inserts provide reusable threads and secure tight threaded joints. An additional benefit is high load carrying capability.

PRESERVATION OF THE THREADED JOINT

The primary benefit for using an Insert is that it preserves the threaded joint integrity for the life of the application. An additional benefit is the unlimited reusable thread.

PROPER SEATING TORQUE

During the assembly process with a mating component, the screw has to be tightened with sufficient torque to introduce the recommended axial tension in order to achieve the required load between the screw and Insert threads to prevent loosening. The larger body diameter and body design of the Insert allow the appropriate installation torque to be applied to the screw.

UNAFFECTED BY STRESS RELAXATION

A common problem with bolted joints in plastic applications is that plastic is susceptible to creep or stress relaxation. Under loads well below the elastic limit, plastics will lose their ability to maintain a load. When this occurs, the threaded connection becomes loose. The brass and aluminium thread provides permanent creep resistance for the entire load path of the thread.

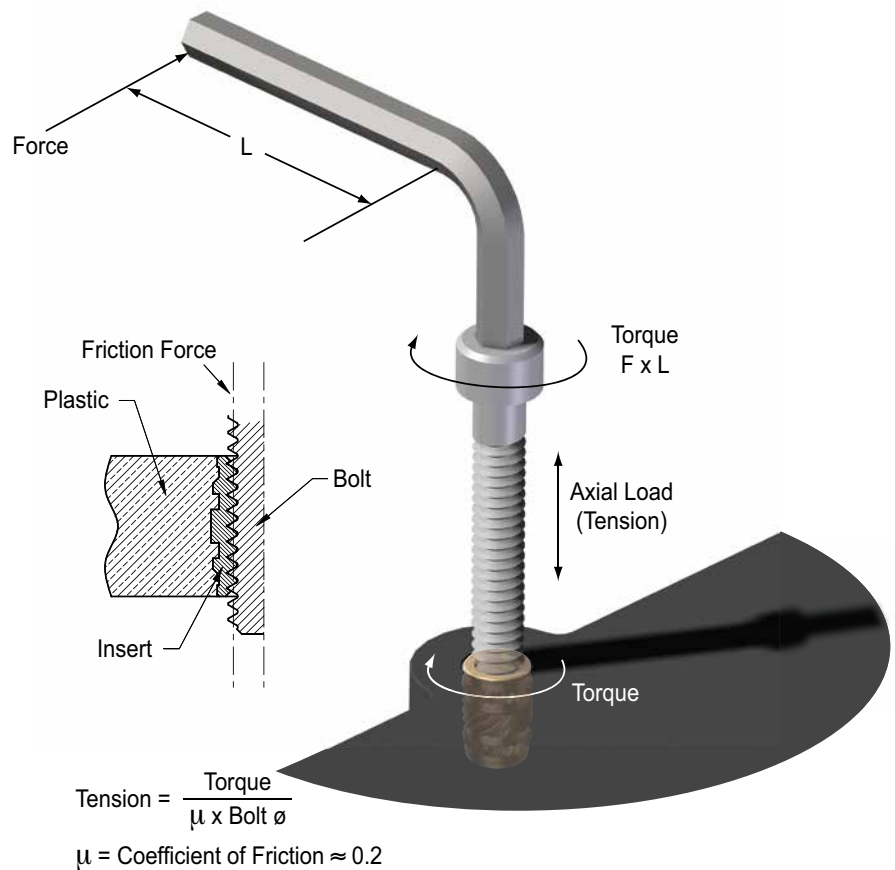

ENHANCE LOAD CARRYING

The load carrying ability of the joint is enhanced by the larger diameter of the Insert as compared to the screw. Inserts are generally twice the diameter of the screw and that increases the shear surface fourfold. Pull-out resistance can further be enhanced by increased Insert length.

TECHNICAL SUPPORT

Since **SPIROL**'s inception in 1948, we have lead the industry in application engineering support for fastening, joining and assembly. Our Inserts are designed to maximise and balance tensile (pull-out) and rotational torque performance. Our Application Engineers have the technical know-how and experience to work together with our customers to develop a cost-effective solution to meet the application requirements.

BROAD PRODUCT RANGE/CAPABILITY

Our leading edge production technology is suitable to meet all your specific needs for both long and short run requirements at competitive pricing. We offer a broad range of standard products and cost-effective methods of producing special features.

QUALITY

Our comprehensive quality concept encompasses not only product quality, but also quality of design and service. Process control, operational discipline and continuous improvement are the foundation of our mission to exceed our customers' expectations. We are IATF 16949, ISO 9001 and ISO 14001 certified.

INSTALLATION SUPPORT

We offer installation technical support and installation equipment. Our standardised, time-tested, modular designs are robust, reliable and easily adjustable – allowing simple customisation to meet the specific needs of an application.

LOCAL DESIGN, GLOBAL SUPPLY

SPIROL has Application Engineers throughout the world to assist you in your designs, supported by state-of-the-art manufacturing centers and worldwide stocking facilities to simplify the logistics of delivering your product.



The objective is to design an Insert with sufficient torque resistance to accommodate the tightening torque necessary to achieve sufficient axial tension load on the threaded joint to keep it together and prevent loosening, while also achieving pull-out values necessary for the load conditions that the Insert will be exposed to while in service.

In general, resistance to torque is a function of diameter and resistance to pull-out is a function of length. These functions, however, are interactive and the challenge for the designer is to achieve the optimum combination of both.

TYPES OF KNURLS



Diamond



Straight



Helical

POST-MOULD INSTALLED WITH HEAT OR ULTRASONIC INSTALLATION

Knurls are used to increase resistance to torque. Straight knurls, as opposed to diamond knurls, are the preferred design. Coarser knurls increase resistance to torque but they also induce greater stress on the plastic. In addition, the circumference of the Insert determines the knurl pitch so there are practical limitations on knurl design. Helical knurls, in comparison to straight knurls, lower torque resistance but increase axial pull-out resistance. In practice, knurl angles between 30 and 45 degrees have a positive impact on pull-out resistance with a minimal loss of torque value. Several knurl bands with different helix angles can be combined on the same Insert to achieve an optimum combination of torque and pull-out resistance.

Some Inserts are designed with a slightly larger diameter knurl band between two slightly smaller diameter knurl bands on either side separated from the larger knurl band by grooves. With a properly designed Insert installed in a hole manufactured as recommended, the plastic will flow over the larger knurl band into the groove and knurls behind the larger knurl band in the opposite direction of installation, significantly increasing pull-out resistance. All the plastic above the larger knurl band in effect becomes a shear plane. A head facilitates plastic flow into the upper grooves of the Insert.

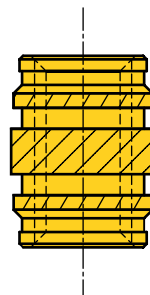

Finally for best performance, it is essential that the Insert is installed axially square to the hole. This can be facilitated with tapering the Insert or by providing a pilot. Pilots need to be of sufficient length and have a plain, unknurled diameter the same size or slightly smaller than the hole.

DETERMINING PROPER INSTALLATION

Retention within the hole is provided by the plastic conforming to the external features of the Insert. A sufficient volume of plastic must be displaced to entirely fill these external features so that the Insert achieves maximum performance when the plastic solidifies. An accurate way of determining sufficient plastic flow into the knurls, barbs and undercuts of the Insert is to take a cross section of the installed Insert and ensure that the features are mirrored in the plastic as shown in *Figures 1* and *2*. It is extremely important to ensure proper plastic flow into the features of the Insert as this dictates the torque and pull-out performance. In *Figure 2*, the plastic did not sufficiently flow into the retention features, which will result in low Insert performance.

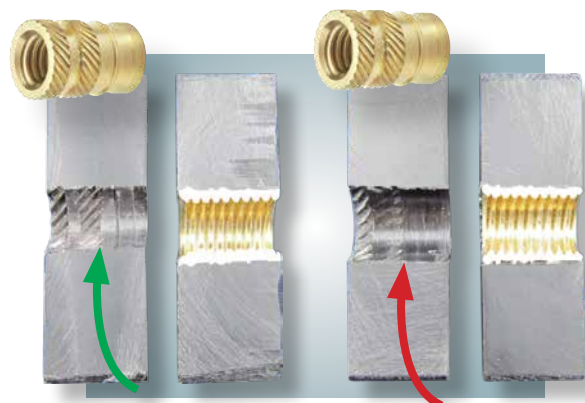

Figure 1. Proper Plastic Flow

Figure 2. Improper Plastic Flow

SELF-TAPPING INSERTS

Provide the best pull-out resistance for a post-mould installed Insert. The threads are designed with a thin profile to minimise inducing stress into the plastic and a relative coarse pitch to provide the maximum plastic shear surface to resist pull-out.

Installation torque is not a problem in that tightening increases the friction between the plastic and threads, and the larger diameter of the external Insert thread increases the frictional surface. Back-out torque performance relies totally on the greater surface area of the external Insert thread and the tension between the threads and plastic.

Again, to facilitate installation square to the hole, a good pilot is essential.

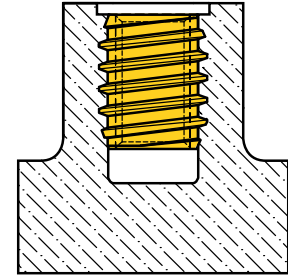

PRESS-IN INSERTS

These Inserts are designed to reduce installation cost at a sacrifice of torque and pull-out performance.

Helical knurls are used to provide both torque and pull-out resistance and to ensure good plastic flow as the Insert rotates into the hole. Installation torque to achieve sufficient tension between the threads is not a problem in that the helical knurls are designed so that the direction of the installation torque will have the tendency to drive the Insert into the hole — which of course is not possible — as the threaded joint is tightened.

A pilot only slightly smaller than the hole and of sufficient length is designed to assure straight Insertion into the hole.

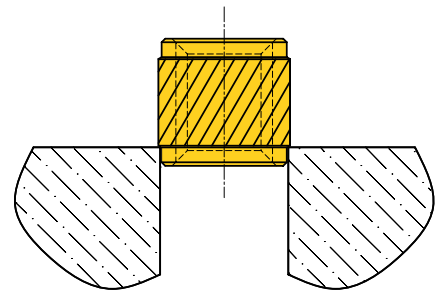

MOULDED-IN INSERTS

This process, although generally more costly in getting the Insert into place than the post-mould installation process, provides the best performance.

Both length and diameter have an impact on pull-out resistance and torque. The challenge is to find the most cost-effective solution that provides/meets the installation torque requirements to achieve a good threaded joint, and the pull-out values that meet the application load requirements.

Helical knurls are the designer's choice to maximise the torque resistance for a given diameter. The volume of these knurls must be such that sufficient plastic is encapsulated in the voids to meet the installation torque requirements for the given bolt.

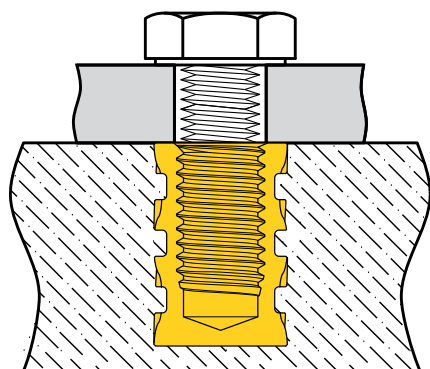

Blind-end Inserts provide an additional alternative to prevent plastic from flowing into the inside of the Insert.

The amount of plastic trapped in the undercuts of the Insert must be sufficient to achieve the pull-out resistance to which the Insert is subjected while in service.

In order to facilitate insertion into the mould squarely on the core pin, the tolerance of the minor thread diameter is reduced for a good fit between the Insert and these mold core pins. Countersinks are designed to simplify the placing of the Insert on the pin.

There are four main commercial categories of plastics: thermoset, thermoplastics, foam and elastomers. The latter two have limited suitability for Insert installation and should an Insert be required, an application analysis is suggested. Accordingly, these categories are not covered here.

Thermoset plastics, once formed, undergo an irreversible chemical change and cannot be reformed using heat and pressure. These plastics are tough and heat-resistant. Examples are Bakelite, urea and polyester resins. Heat/Ultrasonic Inserts are not suitable for these plastics. Thermoset plastics require the use of Moulded-In, Press-In, or Self-Tapping Inserts.

THERMOSET PLASTICS

- Phenolic (Bakelite)
- Epoxies
- Polyimide
- Vulcanised rubber

Thermoplastics are rigid and solid at normal temperatures but at elevated temperatures they soften and melt. Some of the more common plastics in this category are ABS, nylon, PVC and polycarbonate. Heat/Ultrasonic Inserts, as well as other types, are suitable for plastics in this category.

Thermoplastics are further delineated into amorphous and semi-crystalline polymers. **Amorphous polymers** have a random molecular structure that does not have a sharp melting point. Instead, amorphous material softens gradually as temperature rises. Amorphous materials are more sensitive to stress failure due to the presence of hydrocarbons. ABS and PVC are common amorphous thermoplastics. **Semi-crystalline polymers** have a highly ordered molecular structure. These do not soften as the temperature rises, but rather have a defined and narrow melting point. This melting point is generally above that of the upper range of amorphous thermoplastics. PET and PEEK are common semi-crystalline plastics.

Molecular arrangement of polymer chains

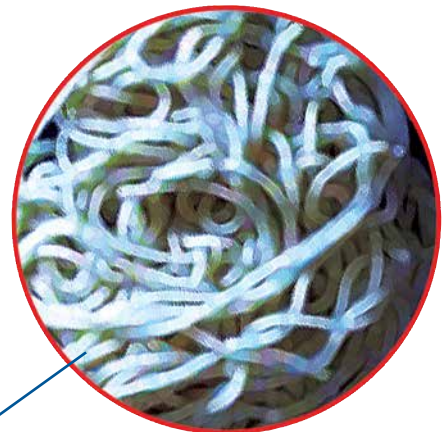

Amorphous

Semi-Crystalline

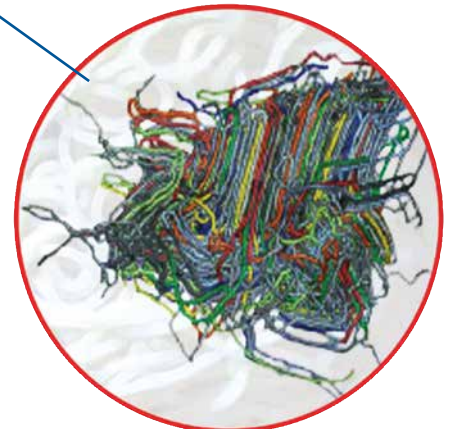

THERMOPLASTICS

Amorphous polymers

- Polymethyl methacrylate (PMMA / Acrylic)
- Polystyrene (PS)
- Polycarbonate (PC)
- Polysulfone (PS)
- PVC
- ABS

Semi-crystalline polymers

- Polyethylene (PE)
- Polypropylene (PP)
- Polybutylene terephthalate (PBT)
- Polyethylene terephthalate (PET)
- Polyetheretherketone (PEEK)

- Polyamide (Nylon)

This can be both amorphous and semi-crystalline based on the blending.

A wide variety of fillers and plasticisers are used to achieve the desired characteristics for the application such as strength, stability, stiffness, conductivity, thermal properties and resistance to creep. Fillers are also used to reduce cost. Fillers and plasticisers increase the stress sensitivity. All fillers generally increase the flow or melt point and therefore, they impact post-mould Insert installation. The impact not only correlates to the type of filler, but also to the percentage used.

- **Holes** for post-mould installed Inserts should always be deeper than the length of the Insert. For Self-Tapping Inserts, a minimum depth of 1.2 times the Insert length is recommended. For other Inserts, the recommended minimum depth is the Insert length plus two (2) Insert thread pitches. The assembly screw should never bottom out in the hole, as jack-out would result.

- **Counterbores** are not recommended for any Insert types except Self-Tapping and Headed Inserts. Counterbores are recommended for Self-Tapping Inserts to reduce the risk of flaking. The outside diameter of the counterbore should be equal to or larger than the outside diameter of the Self-Tapping Insert. The mean counterbore depth should be equal to one thread pitch of the Insert's outer thread.

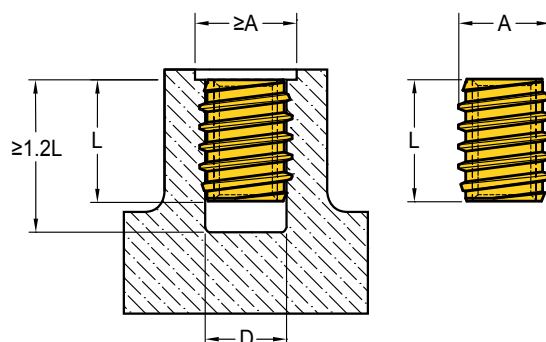

Counterbores are also recommended for Headed Inserts so that the top of the Insert will be flush with the surface of the plastic after installation. The diameter of the counterbore should be 0.5mm (.02") to 1.3 mm (.05") larger than the head diameter of the Insert. The minimum depth of the counterbore should be specified as the thickness of the head. Insert heads are sometimes left above flush to reduce jack-out or improve match-up with the mating component.

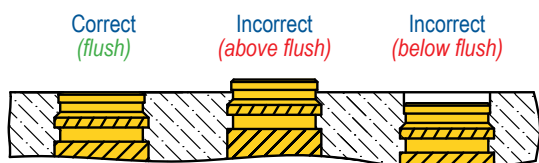

Top of the Insert should be installed as close to flush as possible with the surface of the plastic.

The top of the installed Insert should be flush with the surface of the plastic part with maximum protrusion from the host of 0.13mm (.005"). Additional installation depth tolerance may be assigned so the Insert is slightly below flush. Care should be taken to install the top bearing surface of the Insert as close to flush as possible since a subflush installation presents a jack-out condition.

- **Correct hole size** is critical. Larger holes decrease performance, while smaller holes induce undesirable stresses and potential cracks in the plastic. Undersized holes may also result in flash at the hole edge and make the Insert more difficult to install. The recommended holes need to be reviewed if fillers are used. If the filler content is equal to or greater than 15%, it is suggested to increase the hole 0.08 mm, and if the content is equal to or greater than 35%, the suggested hole increase is 0.15 mm. For intermediate contents interpolation is suggested. Due to the great variety of fillers and plastics and combinations thereof, consultation with **SPIROL** Engineering is strongly recommended.

- **Moulded holes** are preferred over drilled holes. The strong, denser surface of the moulded hole increases performance. Core pins should be large enough to allow for shrinkage. For straight holes, the taper should not exceed a 1° included angle. Tapered holes should have an 8° included angle.

- **Tapered holes** reduce installation time and ensure proper alignment of the Insert to the hole. Only tapered Inserts should be used in tapered holes. Easier release from the core pin is an additional benefit.

- Insert performance is affected by the plastic boss diameter and/or wall thickness. Generally the **optimum wall thickness** or **boss diameter** is two (2) to three (3) times the Insert diameter with the relative multiple decreasing as the Insert diameter increases. The wall thickness has to be enough to avoid bulging during installation, and for boss diameters to be strong enough for the recommended assembly screw installation torque. Poor knit lines will cause failures and reduced Insert performance. Ribs can be added to bosses to add strength.

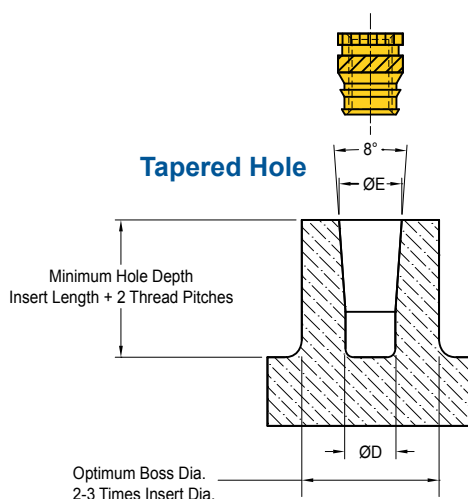
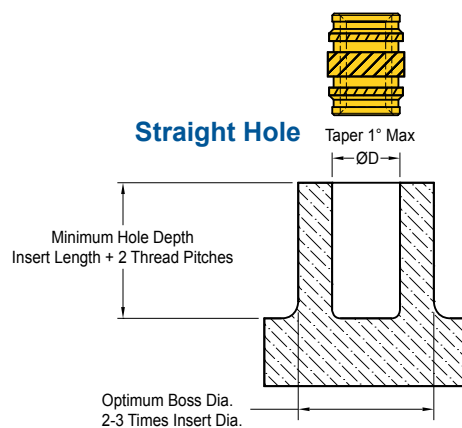

- Post-mould installed Inserts that are **cold-pressed** into the hole require larger boss diameters and/or wall thickness to withstand the greater stresses induced during installation. Installing the Inserts while the plastic is still warm from the moulding process generally eliminates this need.

- The **diameter of the clearance hole in the mating component** is very important. The Insert and not the plastic must carry the load. The hole in the mating component must be larger than the outside diameter of the assembly screw but smaller than the pilot or face diameter of the Insert. This prevents **jack-out**. If a larger hole in the mating component is required for alignment purposes, a headed Insert should be considered. Inserts should be installed flush (or no more than 0.13 mm above the hole).

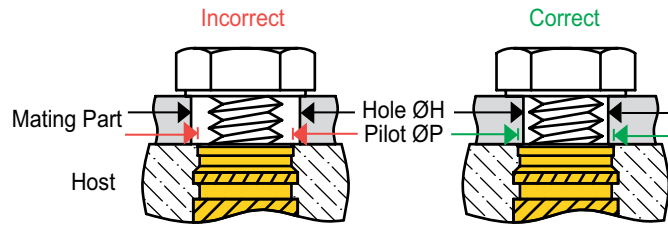

Hole In Mating Part Must Be Smaller Than Insert Pilot Diameter In Host To Prevent The Insert From Pulling Through The Assembly – Known As “Jack-Out”.

- If the mating component is plastic, the use of a **Compression Limiter** should be considered to maintain the preload of the threaded joint. In order for the Compression Limiter to work properly, it should abut the Insert so that the Insert, and not the plastic, carries the load. *For additional information see page 19.*

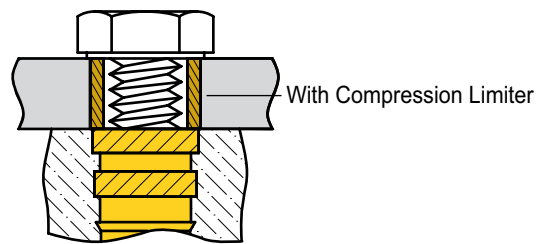

Pull-Through Configuration

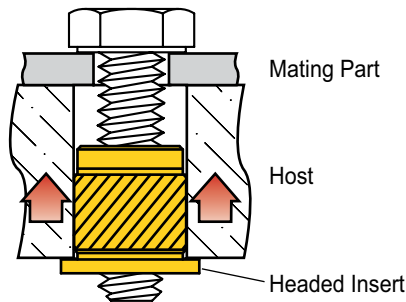

- **Insert heads** provide a larger bearing surface and a conductive surface if this is a requirement. The head also facilitates plastic flow into the upper knurls and grooves for Heat/Ultrasonic Inserts. In high load applications, locating the head opposite the load in a **pull-through configuration** warrants design consideration.

Tapered Inserts should **NOT** be used in pull-through applications or in thin walled bosses as this will cause cracking of the plastic.

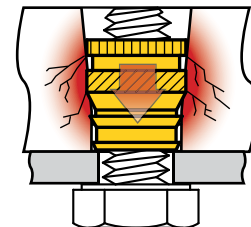

The **SPIROL** Application Engineering Center can provide **impartial advice relative to specifically defined requirements based on extensive experience in the field of Insert design and application. Testing facilities are available, and testing and a report of the results is a free service provided to our customers.**

STANDARD MATERIALS

Type	Grade
A - Aluminium High Strength Aluminium Alloy	ASTM B211 2024 ISO AlCu4Mg1
E - Brass Free-Cutting Brass	ASTM B16 UNS C36000 EN 12164 CW603N CuZn36Pb3
RoHS compliant	

ORDER DESCRIPTION

INS (Series #) / Thread Size / Length Material Finish
Example: INS 29/8-32 / .321L EK

SPIROL has a broad range of Inserts for post-mould installation as well as a series of Moulded-In Inserts. Installation of Inserts after moulding reduces in-place cost by shortening moulding time and eliminating secondary cleaning. This method also reduces rejects and mould damage resulting from dislodged Inserts. Moulded-In Inserts are placed into the mould cavity prior to plastic injection and offer exceptional torque and pull-out resistance due to unrestricted plastic flow.

HEAT/ULTRASONIC INSERTS are designed for post-mould installation in thermoplastics. Heat and ultrasonic installation yield outstanding performance results. Available in long and short variations, long for maximum torque and pull-out resistance; short for less stringent requirements with the benefits of lower cost and reduced installation time.

Pages 8 and 9



Series 19 and 29 are designed for straight holes using standard core pins. The same hole diameter applies to all Inserts within these Series. Seating and installation are facilitated with a pilot and a tapered knurl and groove design. The Series 29 is symmetrical to eliminate the need for orientation.

Pages 8 and 9



Series 20 and 30 are headed versions using the same body style as Series 19 and 29 respectively.

Page 10



Series 14 are designed for use in tapered holes. The tapered hole facilitates proper seating and maximises the surface contact between the Insert and hole wall prior to the application of heat or ultrasonic vibration.

Page 11



SELF-TAPPING INSERTS are available in **Series 10** which is a Thread Forming Insert for soft, flexible thermoplastics.

Page 12

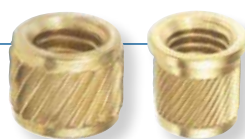

PRESS-IN INSERTS are ideal for use in softer plastics to provide a reusable thread which can meet the tightening torque requirements for a threaded joint. Moderate pull-out and good torque requirements are provided by the helical knurl which also facilitates good plastic flow. **Series 50 and 51** Inserts allow for easy and quick installation. The Series 50 is symmetrical with a generous pilot. Series 51 is the headed version which is also suitable for pull-through applications where high pull-out force is a requirement.

Page 13



MOULDED-IN INSERTS are designed for maximum pull-out and torque performance, and are often the Insert of choice for thermosets and engineered plastics with a high percentage of filler. The minor thread diameter tolerance is controlled to ensure positive positioning and perpendicularity of the Insert on the core pin during the moulding process. **Series 63** is symmetrical eliminating orientation and **Series 65** is the same body style in a blind ended version. These Inserts are made from 2024 aluminium, a light-weight, lead-free grade.

Series 19 Short

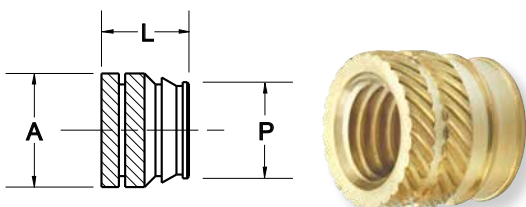

Series 19 Long

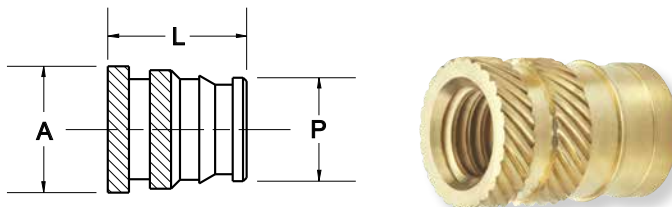

Series 20 Short

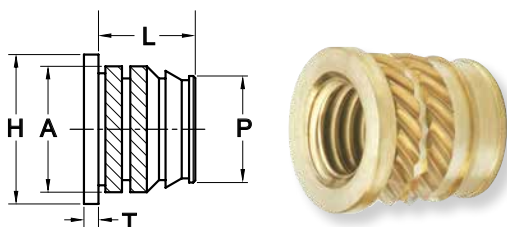

Series 20 Long

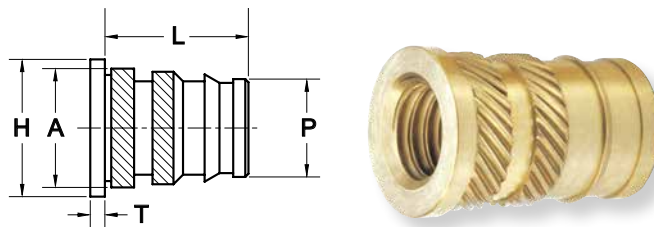

DIMENSIONAL DATA

LEGEND

Inch
Metric Conversion

Thread Size	A Short Overknurl Ø		A Long Overknurl Ø		P Pilot Ø		L Short Length		L Long Length		T Head Thickness		H Head Ø		D* Rec. Hole Ø		
	Tolerance ▶	Ref.	Ref.	Ref.	±0.003	±0.008	±0.005	±0.13	±0.005	±0.13	±0.003	±0.08	±0.003	±0.08	+0.003	+0.08	
2-56	M2 x 0.4	.141	3.58	.143	3.63	.123	3.12	.125	3.18	.157	3.99	.018	0.46	.185	4.70	.126	3.20
4-40	M2.5 x 0.45 M3 x 0.5	.182	4.62	.187	4.75	.154	3.91	.140	3.56	.226	5.74	.021	0.53	.216	5.49	.157	3.99
6-32	M3.5 x 0.6	.213	5.41	.218	5.54	.185	4.70	.150	3.81	.281	7.14	.027	0.69	.247	6.27	.188	4.78
8-32	M4 x 0.7	.246	6.25	.251	6.38	.218	5.54	.185	4.70	.321	8.15	.033	0.84	.278	7.06	.221	5.61
10-24 10-32	M5 x 0.8	.277	7.04	.282	7.16	.249	6.32	.250	6.35	.375	9.53	.040	1.02	.310	7.87	.252	6.40
1/4-20	M6 x 1.0	.340	8.64	.345	8.76	.312	7.92	.312	7.92	.500	12.70	.050	1.27	.372	9.45	.315	8.00
5/16-18	M8 x 1.25	—	—	.407	10.34	.374	9.50	—	—	.500	12.70	.050	1.27	.435	11.05	.377	9.58

Recommended Hole Design*

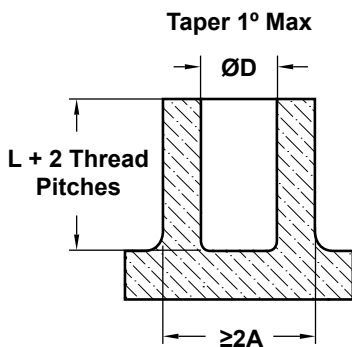

* See page 5 for more information on recommended hole design

Series 29 Short

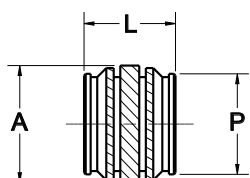

Series 29 Long

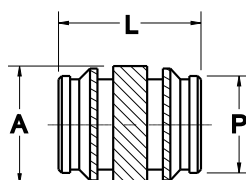

Series 30 Short

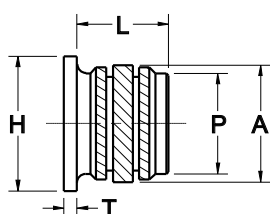

Series 30 Long

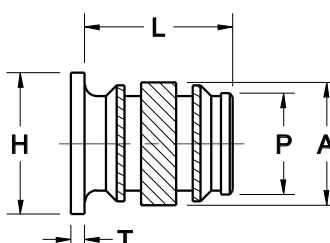

DIMENSIONAL DATA

LEGEND

Inch
Metric Conversion

Thread Size	A Overknurl Ø		P Pilot Ø		L Short Length		L Long Length		T Head Thickness		H Head Ø		D* Rec. Hole Ø	
	Tolerance ▶	Ref.	±.003	±0.08	±.005	±0.13	±.005	±0.13	±.003	±0.08	±.003	±0.08	+0.03	+0.08
2-56	M2 x 0.4	.143 3.63	.123	3.12	.125	3.18	.157	3.99	.018	0.46	.185	4.70	.126	3.20
4-40	M2.5 x 0.45 M3 x 0.5	.187 4.75	.154	3.91	.140	3.56	.226	5.74	.021	0.53	.216	5.49	.157	3.99
6-32	M3.5 x 0.6	.218 5.54	.185	4.70	.150	3.81	.281	7.14	.027	0.69	.247	6.27	.188	4.78
8-32	M4 x 0.7	.251 6.38	.218	5.54	.185	4.70	.321	8.15	.033	0.84	.278	7.06	.221	5.61
10-24 10-32	M5 x 0.8	.282 7.16	.249	6.32	.250	6.35	.375	9.53	.040	1.02	.310	7.87	.252	6.40
1/4-20	M6 x 1.0	.345 8.76	.312	7.92	.312	7.92	.500	12.70	.050	1.27	.372	9.45	.315	8.00
5/16-18	M8 x 1.25	.407 10.34	.374	9.50	—	—	.500	12.70	.050	1.27	.435	11.05	.377	9.58

Recommended Hole Design*

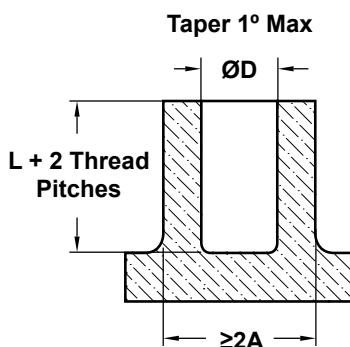

* See page 5 for more information on recommended hole design

To Order: INS (Series #)/Thread Size / Length, Material, Finish
Example: INS 29/10-24 / .375L EK

Series 14 Short

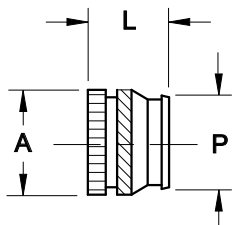

Series 14 Long

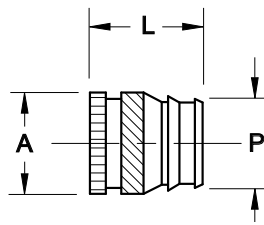

DIMENSIONAL DATA

LEGEND

Inch
Metric Conversion

Short	Thread Size		A Overknurl Ø		P Pilot Ø		L Length		E* Rec. Hole Ø at Entrance		D* Rec. Hole Ø at Tapered End	
	Tolerance ▶		Ref.		±.003	±.008	±.005	±.013	+ .002	+ .005	+ .002	+ .005
	2-56	M2 x 0.4	.141	3.58	.119	3.02	.115	2.92	.123	3.12	.118	3.00
4-40	M2.5 x 0.45	.174	4.42	.156	3.96	.135	3.43	.159	4.04	.153	3.89	
6-32	M3 x 0.5 M3.5 x 0.6	.221	5.61	.203	5.16	.150	3.81	.206	5.23	.199	5.05	
8-32	M4 x 0.7	.249	6.32	.230	5.84	.185	4.70	.234	5.94	.226	5.74	
10-24 10-32	—	.297	—	.272	—	.225	—	.277	—	.267	—	
—	M5 x 0.8	—	8.38	—	7.85	—	6.73	—	8.00	—	7.70	
1/4-20	M6 x 1.0	.378	9.60	.356	9.04	.300	7.62	.363	9.22	.349	8.86	

Long	Thread Size		A Overknurl Ø		P Pilot Ø		L Length		E* Rec. Hole Ø at Entrance		D* Rec. Hole Ø at Tapered End	
	Tolerance ▶		Ref.		±.003	±.008	±.005	±.013	+ .002	+ .005	+ .002	+ .005
	2-56	M2 x 0.4	.141	3.58	.112	2.84	.188	4.78	.123	3.12	.107	2.72
4-40	M2.5 x 0.45	.174	4.42	.146	3.71	.219	5.56	.159	4.04	.141	3.58	
6-32	M3 x 0.5 M3.5 x 0.6	.221	5.61	.190	4.83	.250	6.35	.206	5.23	.185	4.70	
8-32	M4 x 0.7	.249	6.32	.213	5.41	.312	7.92	.234	5.94	.208	5.28	
10-24 10-32	—	.297	—	.251	—	.375	—	.277	—	.246	—	
—	M5 x 0.8	—	8.38	—	7.19	—	11.13	—	8.00	—	7.06	
1/4-20	M6 x 1.0	.378	9.60	.326	8.28	.500	12.70	.363	9.22	.321	8.15	
5/16-18	M8 x 1.25	.469	11.91	.406	10.31	.562	14.27	.448	11.38	.401	10.19	

Recommended Hole Design*

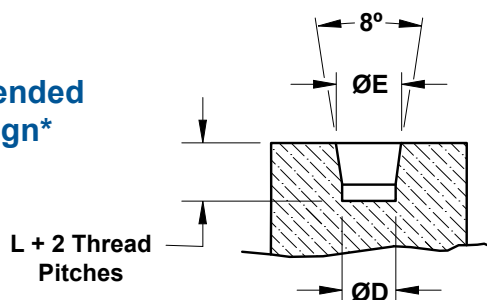

* See page 5 for more information on recommended hole design

Reduced thread profile and coarse pitch minimises radial stress and potential hole wall damage. The coarse thread also maximises the pull-out strength of these Self-Tapping Inserts.

Series 10 Thread Forming



DIMENSIONAL DATA

LEGEND

Inch
Metric Conversion

Thread Size		A Outer Thread Ø		L Length		D* Rec. Hole Ø		F* Counterbore Depth	
Tolerance ▶		Ref.		±.010	±0.26	+.003	+0.08	Ref.	
4-40	M3 x 0.5	.188	4.78	.250	6.35	.169	4.29	.042	1.07
6-32	M3.5 x 0.6	.219	5.56	.281	7.14	.199	5.05	.042	1.07
8-32	M4 x 0.7	.250	6.35	.312	7.92	.228	5.79	.050	1.27
10-24	M5 x 0.8	.281	7.14	.375	9.53	.250	6.35	.063	1.60
10-32	M5 x 0.8	.281	7.14	.375	9.53	.250	6.35	.063	1.60
1/4-20	M6 x 1.0	.344	8.74	.438	11.13	.312	7.92	.071	1.81

Recommended Hole Design*

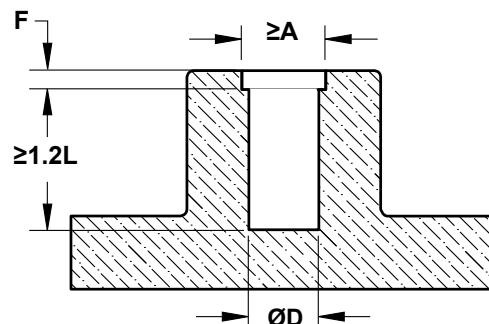

* See page 5 for more information on recommended hole design

To Order: INS (Series #)/Thread Size / Length, Material, Finish
Example: INS 10/250-20 / .438 EK

Series 50

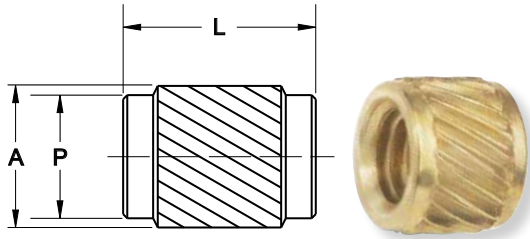

Series 51

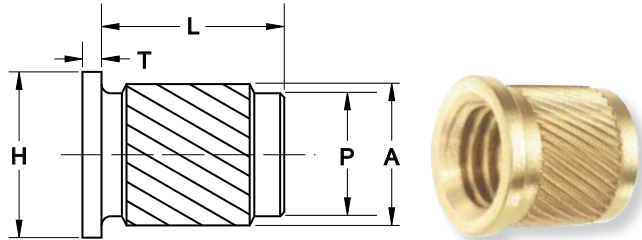

DIMENSIONAL DATA

LEGEND

Inch
Metric Conversion

Thread Size	A Overknurl Ø		P Pilot Ø		L Length		T Head Thickness		H Head Ø		D* Rec. Hole Ø		
	Tolerance ▶	Ref.	±.003	±0.08	±.005	±0.13	±.003	±0.08	±.003	±0.08	+0.003	+0.08	
2-56	M2 x 0.4	.134	3.40	.121	3.07	.125	3.18	.018	0.46	.185	4.70	.124	3.15
4-40	M2.5 x 0.45 M3 x 0.5	.165	4.19	.152	3.86	.140	3.56	.021	0.53	.216	5.49	.155	3.94
6-32	M3.5 x 0.6	.196	4.98	.183	4.65	.150	3.81	.027	0.69	.247	6.27	.186	4.72
8-32	M4 x 0.7	.227	5.77	.214	5.44	.185	4.70	.033	0.84	.278	7.06	.217	5.51
10-24 10-32	M5 x 0.8	.259	6.58	.246	6.25	.250	6.35	.040	1.02	.310	7.87	.249	6.32
1/4-20	M6 x 1.0	.321	8.15	.308	7.82	.312	7.92	.050	1.27	.372	9.45	.311	7.90
5/16-18	M8 x 1.25	.384	9.75	.371	9.42	.375	9.53	.050	1.27	.435	11.05	.374	9.50

Recommended Hole Design*

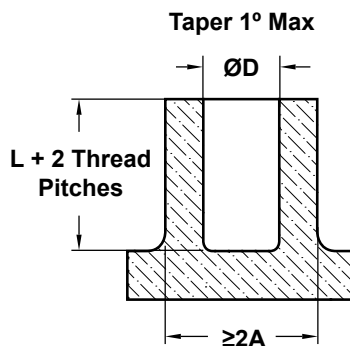

* See page 5 for more information
on recommended hole design

Series 63 Through Hole

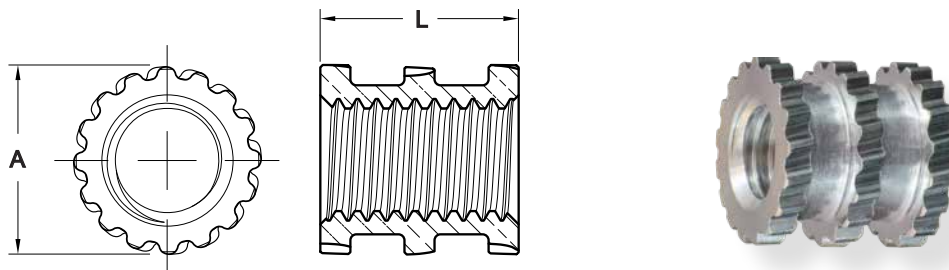

Series 65 Blind End

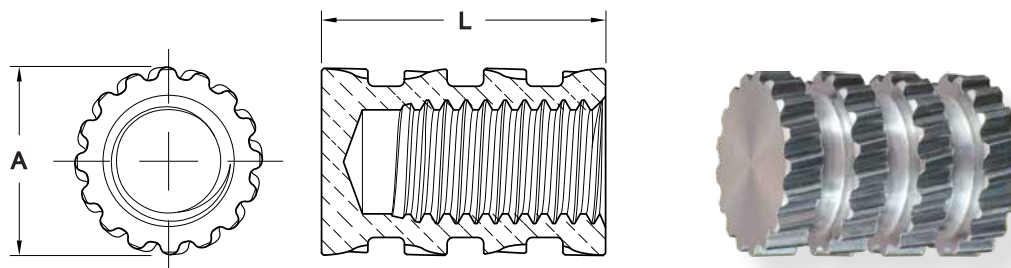

DIMENSIONAL DATA

Thread Size		A Outer Ø		L Length Series 63		L Length Series 65		Minimum # Threads Series 65		Minimum Minor Ø	
Tolerance ▶		Ref.		±.005	±0.13	±.005	±0.13	—		—	
8-32	M4 x 0.7	.272	6.90	.256	6.50	.380	9.65	6	7	.1365	3.289
10-24	M5 x 0.8	.309	7.85	.325	8.25	.459	11.65	5	8	.1495	4.229
1/4-20	M6 x 1.0	.367	9.33	.394	10.00	.610	15.50	6	9	.2005	4.991
5/16-18	M8 x 1.25	.463	11.75	.463	11.75	.697	17.70	6	8	.2575	6.769

LEGEND

Inch
Metric

To Order: INS (Series #)/Thread Size / Length, Material, Finish
Example: INS 65/312-18 / .697 AK

SPIROL's Application Engineers stand ready to help you with your threaded joint, whether it be the application of an Insert or a Compression Limiter, to ensure continued integrity of the bolted connection. When reviewing your design requirements, our Application Engineers will help you select the most appropriate component to achieve your performance and cost objectives. As it's beneficial to you, our first option will be to recommend the use of a standard Insert or Compression Limiter, but if these do not meet the application's requirements, we will design and produce a custom component which will.

Examples of special offerings:

- **Threaded studs**
- **Special knurl configurations and external features for unique installation and performance requirements**
- **Special materials:**
 - 300 Series Austenitic Stainless Steel
 - 12L14 Steel
- **Special plating requirements:**
 - Nickel Plate
 - Zinc Plate
 - Black Zinc Plate
- **Cross-drilled holes**
- **Special internal threads and hole dimensions**
- **Tighter than standard tolerances**
- **Unique diameter and length combinations**
- **Special designs for non-traditional plastics**

Engage us early on your next design!



HEAT INSTALLATION



Heat installation is a highly versatile method to install Inserts into thermoplastics with only temperature and pressure as variables. Care has to be taken to assure that the heated Insert softens and not melts the plastic. This will avoid flash and keep the Insert in place as the plastic re-solidifies. A piloted tip should be used to guide the Insert during installation and extended tips provide access to recessed holes. The Insert should be installed flush with the surface, and this is usually accomplished with a positive stop.

Fixturing is simple when installing with heat; the sole purpose being to position the hole under the installation tip. Rigidity is not an issue. The radial stresses are minimal. **This makes heat insertion ideal for thin walls or components which are difficult to fixture with the rigidity required for ultrasonic installation.** Since only a low insertion pressure is used and there is no vibration, the contact area between the driver and Insert is not critical, making this process ideal for symmetrical Inserts with small bearing surfaces.

There are two methods of applying heat to the Insert: 1) with a heat tip that transfers heat to an Insert which has been manually placed into the hole, and 2) with a pre-heat chamber which heats the Insert to the appropriate temperature and the installation is with a non-heated quill. The latter method is utilised in the **SPIROL Model HA** Automatic Heat Insert Driver. Since the Insert cools during installation, this method is not suitable for plastics with a high filler content or for Inserts that do not retain heat well. The pressure and temperature settings for these machines are programmed into the controller, and these drivers are set up for a specific Insert/plastic combination.



Model HA

The heated tip method is employed in the **SPIROL Model HP** pneumatic and **Model PH** platen multi-tip heat Insert drivers. Here, it is recommended to start with a temperature 28°C (50°F) above the initial softening temperature for the plastic in question. For plastics with fillers, this initial differential should be 83°C (150°F). Pressure is Insert-size dependent and should be as low as possible in the 0.03 MPa to 0.10 MPa range. The pressure should be just enough to push the Insert into the hole as the plastic melts.

Model HP



The process of determining the right temperature/pressure combination is not complex, but it takes some experimentation. It is suggested that an installed Insert be sectioned through its center line, and that the Insert halves then be removed from the plastic material. The plastic material should then reveal a negative image of the Insert profile. This defines the correct settings and assures optimum performance.

Model PH



We also offer the **SPIROL Model HM** manual insertion press.

Model HM



PRESS-IN INSERT INSTALLATION



This is the easiest installation method. Place the Insert pilot into the hole and use a hammer or arbor press to seat it. A piloted, extended punch can be used for recessed locations. In high volume applications, an automatic Insert Driver such as a **SPIROL Model PR** or **Model CR** can be used to feed the Inserts into position and press them into place. Series 50 Inserts are symmetrical, and Series 51 can be easily oriented.

ULTRASONIC INSERT INSTALLATION



Ultrasonic installation is a very effective—but complex—method of installing Inserts. The effective application of this technology requires expertise to assure consistent quality. The variables are amplitude, down speed, pressure and weld time. A special hardened steel or carbide-faced horn is required to minimise wear.



The Insert is placed into the hole and the horn of the ultrasonic inserter is pressed down on the Insert. The horn transmits ultrasonic vibration to the Insert and the friction from the vibration of the Insert melts a thin film of plastic to the metal-plastic interface. Pressure from the horn forces the Insert into the hole. When the horn is removed, the melted plastic next to the Insert solidifies. The Inserts should be installed flush with the surface. The horn travel needs to be limited either mechanically or with switches.

Fixturing of the plastic component is very important when ultrasonically installing an Insert. It has to be held rigid to get the desired vibration between the Insert and the plastic. 20% of the Insert area should be in contact with the plastic prior to the application of vibration and pressure. A tapered hole combined with a tapered Insert facilitates a sufficient contact area. A pre-trigger switch is recommended to prevent cold-pressing the Insert into place. A large contact area between the horn and Insert is also desirable.

The ultrasonic method is limited to thermoplastics and is particularly suitable for amorphous polymers which have a broad softening temperature range. This allows the plastic material to soften gradually, thus tolerating a wide range of pressure/amplitude combinations. Semi-crystalline polymers have a sharp, comparatively higher melting point and resolidify rapidly. This requires more energy, i.e. a higher amplitude, and special consideration to the variable settings.



Model CR

A bench press with a simple ram for Press-In Insert installation



As a general guideline, the preferred parameter for the ultrasonic Insert installation process can be summarized as follows:

- Low to medium amplitude
- Low to medium pressure
- Pre-trigger
- Slow-down speed
- Minimum weld time
- Hardened horn
- Rigid fixturing

SELF-TAPPING INSERT INSTALLATION



Since the Insert is driven by its internal thread, a different driving stud is required for each Insert size. For applications in recessed areas or close to walls, an extension driver is the solution. The Insert is threaded onto the driver by hand and the manual press is brought down to line the Insert up with the hole. The plastic component should be located against a stop to prevent rotation during installation, or fixtured to prevent rotation as well as to ensure consistent alignment of the hole. After the Insert is seated, releasing the pressure automatically reverses and raises the driver. The Insert should always be installed flush or slightly below the surface.

The **SPIROL Model TA** Automatic Self-Tapping Insert Driver eliminates the need to manually place Inserts. The Inserts are automatically fed to and fixed onto the driving stud while the operator unloads the assembled component and loads a new component. The sequence of this cycle is shown below.



Model TA

Model TA Insert installation sequence

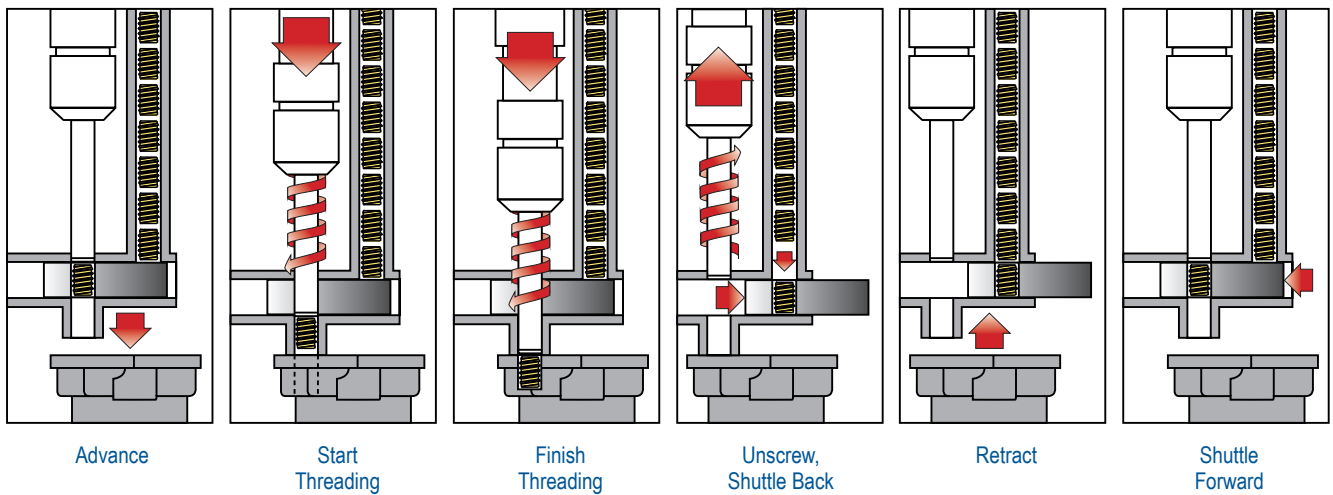

If multiple Insert locations are required, a **Radial Arm Driver** can be used. It is important that whatever is used provides rigidity to assure straight axial insertion of the Insert into the hole.



Radial Arm Driver

ADVANTAGES OF HEAT INSTALLATION OVER ULTRASONIC

As much as 75% of the Insert's performance is a direct result of how well it was installed, therefore all of the factors that impact installation must be carefully controlled in order to maximise performance. With so many different combinations of Insert types, plastic types, and performance requirements, it is recommended that manufacturers partner with SPIROL as early as possible in the design stage. Proper choice of the Insert and the installation process are both critical to part integrity for the intended life of the assembly. Heat installation of Inserts has many advantages to help control these variables.



RELIABLE & CONSISTENT

Lower installation forces enable insertion into thin-walled parts which would be destroyed by ultrasonic equipment. With consistent and adjustable temperature, force and depth settings, an installed Insert with predictable pull-out and torsion failure forces can be designed for the application.

QUIET

Quiet operation eliminates the harsh noise associated with ultrasonic installation.

MORE ECONOMICAL

Heat installation machines are about 50% less expensive than similar ultrasonic equipment because they are less complex and do not require as many components. Heat installation is comprised of using a heated tip and the insertion force is pneumatically driven under low force; generally under 220 N (50 lbs.) Ultrasonic installation requires an electronic power supply, cycle controlling timers, an electrical or mechanical energy transducer, and an ultrasonic horn.

EASY INSERTION INTO DEEP RECESSES

Longer heat tips can be used to enable insertion into deep recesses within a part which would be inaccessible to an ultrasonic horn.

VERSATILE

- The heat installation method is extremely adaptable. Applications that need multiple Inserts on multiple planes can be catered to with platen style heat machines. Prototyping or low volume applications can be catered to with manual heat machines.
- Wide range of Insert sizes can be accommodated on the same machine by switching out the interchangeable heat tips.
- Any Insert can be installed – headed or non-headed.
- Heat insertion modules can be equipped with vibratory bowl feeders so that the operator does not need to physically touch the Insert during the entire installation process. The Inserts would simply be loaded into a vibratory feeder and advance through the feed tube to a guarded heating chamber. The operator would then load the plastic molded component into the fixture, and activate the machine to install the Insert.
 - This is extremely important for very small Inserts, which are difficult to singulate and orient.

MINIMAL MAINTENANCE

Heat machines seldom need maintenance (if ever). Replacement heat tips, maintenance and spare parts are inexpensive as compared with ultrasonic equipment costs.

HIGHER PERFORMANCE

Generally, higher performance can be expected from heat installation because of the “through-heating” of the Insert. This enables the melted plastic to fully flow into all retention features. Performance of Inserts that are ultrasonically installed is often times lower because the plastic is not able to fully flow into retention features. This happens because of the minimal heating generated only at the point of interference between the Insert and the host.

POTENTIAL DISADVANTAGES

Heat insertion's slightly longer process time for installation of a single Insert (when the Insert is not preheated) is balanced by its many advantages over ultrasonic installation.

The flexibility, consistency, high performance, and price of heat insertion make it the best choice for installing Inserts into plastic for many applications.

In applications where the mating component is also plastic, a Compression Limiter is necessary to avoid the creep or stress relaxation in the mating component from reducing the frictional load in the threaded joint.



Similar to Inserts, Compression Limiters are used to ensure bolted joint integrity in plastic assemblies. As the bolt is tightened to achieve the required friction between threads, the plastic is compressed. The Compression Limiter absorbs the force generated during tightening of the bolt, and isolates the plastic from excessive compressive loads. Without the Compression Limiter, plastic will creep resulting in the loosening and eventual failure of the joint. The Compression Limiter ensures that the joint remains intact throughout the life of the product.

It is essential for the Compression Limiter to be in contact with the Insert and the condition described in the first paragraph on page 6 needs to be avoided. The Insert – and not the plastic – must carry the load. A jack-out condition is not acceptable.

SPIROL offers a variety of standard **Compression Limiters** enabling the most cost effective component to be chosen for each particular assembly depending on performance requirements and installation method.



Series CL200 and CL350



Series CL400 and CL460



Series CL500



Series CL600 and CL601



Series CL800 and CL801

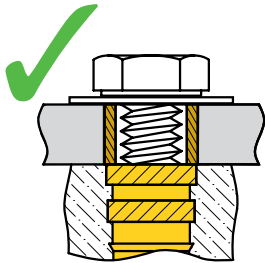

Proper configuration

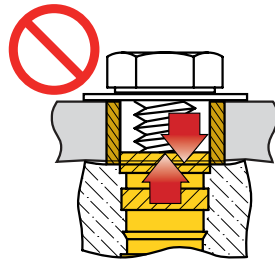

Jack-out

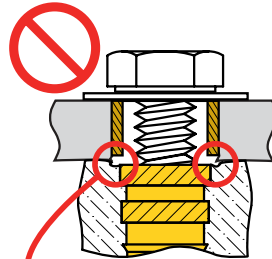

Plastic creep

Headed Inserts – **SPIROL** Series 20, 30 and 51 are designed to increase the contact surface for the Compression Limiters. In addition, **SPIROL** Series 14, 19, 63 and 65 generally have adequate surface area. In any event, at the design stage proper contact needs to be evaluated.

In applications using multiple Inserts where misalignment needs to be accommodated, the standard solution is to increase the clearance between the internal diameter of the Compression Limiter and the external diameter of the assembly screw. This obviously has the potential of the Compression Limiter not aligning satisfactorily with the Insert. In these situations a Headed Insert is always recommended. Consideration can also be given to increasing the wall thickness of the Compression Limiter.

If the bearing surface of the mating Insert is too small for the inside diameter of the Compression Limiter, then a special Compression Limiter with reduced clearance between the assembly screw may resolve the problem. This of course also reduces permissible misalignment.

If the surface area of the Insert is inadequate for proper contact with the Compression Limiter, then the only solution is using a plastic in the mating component which has good anti-creep characteristics and using a Compression Limiter with maximum wall thickness for better distribution of the load. Jack-out in the situations will be a concern and needs to be addressed with avoiding over-torquing the assembly screw.

TESTING METHODS AND TERMINOLOGY

SPIROL Inserts are designed to maximise and balance tensile (pull-out) and rotational torque performance. Attention to knurl and thread quality further enhances performance. **Quality Control** assures the consistency of performance.

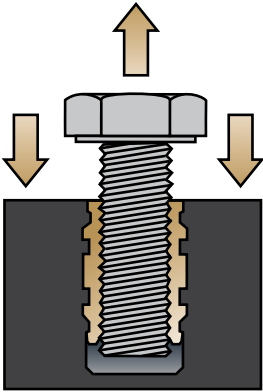

TENSILE (PULL-OUT) STRENGTH

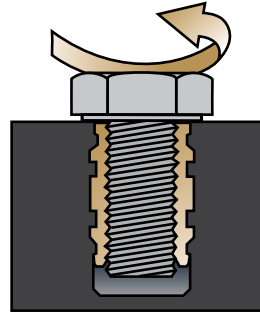

ROTATIONAL TORQUE

The **axial force** required to pull the Insert out of the plastic material. This test is performed using a qualified tensile testing machine. A load curve is recommended for analysis purposes.

The **rotational force** required to rotate the Insert in the plastic material. In practice, the friction between the screw head and mating component comes into play providing an additional safety factor. A calibrated torque wrench can be used for this test.

PERFORMANCE

The following factors impact Insert performance:

- Insert type, design with type and quality of the Insert features,
- Plastic material and filler composition,
- Design and quality of the plastic components including hole consistency,
- Installation process and resultant quality, and
- Alignment of the mating component and how it supports the installed Insert.

The **correct installation** settings are critical to Heat/Ultrasonic Insert performance. The tapping process for Self-Tapping Inserts has to be set to avoid hole reaming. Improper installation can have devastating effects on performance.

HEAT-ULTRASONIC INSERTS (Straight Holes)

Thread Size		INS 19 Short		INS 19 Long		INS 29 Short		INS 29 Long	
Unified	Metric	Tensile lbs. (N)	Torque in-lbs. (N-m)	Tensile lbs. (N)	Torque in-lbs. (N-m)	Tensile lbs. (N)	Torque in-lbs. (N-m)	Tensile lbs. (N)	Torque in-lbs. (N-m)
2-56	M2	100 (445)	4 (0.4)	150 (665)	5 (0.5)	125 (555)	4 (0.4)	175 (780)	5 (0.5)
4-40	M2.5 M3	175 (780)	14 (1.5)	325 (1,445)	28 (3)	225 (1,000)	14 (1.5)	425 (1,890)	28 (3)
6-32	M3.5	275 (1,220)	30 (3.5)	500 (2,220)	55 (6)	325 (1,445)	30 (3.5)	625 (2,780)	55 (6)
8-32	M4	375 (1,670)	53 (6)	650 (2,900)	80 (9)	446 (2,000)	62 (7)	850 (3,800)	90 (10)
10-24 10-32	M5	550 (2,450)	90 (10)	850 (3,800)	125 (14)	650 (2,900)	100 (11)	1,100 (4,900)	135 (15)
1/4-20	M6	750 (3,350)	140 (16)	1,050 (4,650)	185 (21)	900 (4,000)	150 (17)	1,400 (6,200)	200 (23)
5/16-18	M8	900 (4,000)	250 (28)	1,300 (5,800)	290 (33)	1,200 (5,350)	250 (28)	1,800 (8,000)	310 (35)

The variety of plastic materials and fillers and the complexity of component design makes it impossible to provide Insert performance data which can be applied to specific applications. The data provided herein should only be used as a general comparative guide.

HEAT-ULTRASONIC INSERTS *(Tapered Holes)*

Thread Size		INS 14 Short		INS 14 Long	
Unified	Metric	Tensile lbs. (N)	Torque in-lbs. (N-m)	Tensile lbs. (N)	Torque in-lbs. (N-m)
2-56	M2	50 (220)	3 (0.3)	125 (560)	9 (1)
4-40	M2.5	175 (780)	18 (2)	300 (1,330)	27 (3)
6-32	M3 M3.5	225 (1,000)	27 (3)	450 (2,000)	35 (4)
8-32	M4	300 (1,350)	30 (3.5)	575 (2,550)	45 (5)
10-24 10-32	—	450 (2,000)	45 (5)	750 (3,330)	70 (8)
—	M5	550 (2,450)	88 (10)	950 (4,200)	135 (15)
1/4-20	M6	850 (3,800)	140 (16)	1,300 (5,800)	220 (25)
5/16-18	M8	1,200 (5,350)	265 (30)	2,000 (8,900)	355 (40)

SELF-TAPPING INSERTS

Thread Size		INS 10
Unified	Metric	Tensile lbs. (N)
4-40	M3	600 (2,650)
6-32	M3.5	900 (4,000)
8-32	M4	1,225 (5,500)
10-24 10-32	M5	1,700 (7,500)
1/4-20	M6	2,250 (10,000)
5/16-18	M8	2,800 (12,500)

PRESS-IN INSERTS

Thread Size		INS 50	
Unified	Metric	Tensile lbs. (N)	Torque in-lbs. (N-m)
4-40	M3	75 (330)	18 (2)
6-32	M3.5	90 (400)	27 (3)
8-32	M4	115 (500)	50 (5.5)
10-24 10-32	M5	150 (675)	75 (8.5)
1/4-20	M6	180 (800)	135 (15)
5/16-18	M8	225 (1,000)	230 (26)

MOULDED-IN INSERTS

Thread Size		INS 63	INS 65
Unified	Metric	Tensile lbs. (N)	Tensile lbs. (N)
8-32	M4	1,200 (5,360)	1,420 (6,300)
10-24	M5	1,720 (7,650)	1,990 (8,860)
1/4-20	M6	2,430 (10,830)	2,900 (12,890)
5/16-18	M8	3,030 (13,480)	3,660 (16,290)

The **SPIROL Series 63** and **65** Moulded-In Inserts far exceeded the maximum recommended tightening **torque** of a Class 12.9 (Grade 8) bolt.

SPIROL has extensive historic performance data on which to base an initial recommendation. It is, however, **SPIROL's** preference to test the Insert in your application and determine the installation criteria that will yield the best performance. You will receive a written report. We suggest consultation at the earliest stages in product development.

Performance Test Results:

- Inserts were installed into bosses at least 2 times the Insert diameter.
- The INS 63's and INS 65's were molded into unfilled nylon 6.
- All post-mold installed Inserts were tested in unfilled nylon 6/6 bosses with drilled holes.
- The INS 10's were threaded into the holes, and the INS 50's were pressed into the holes. All other Inserts were heat installed.
- The performance of the headed versions of any Insert will be the same or slightly better than the non-headed version.

Technical Centres

Europe SPIROL United Kingdom
17 Princewood Road
Corby, Northants
NN17 4ET United Kingdom
Tel. +44 1536 444800
Fax. +44 1536 203415

SPIROL France
Cité de l'Automobile ZAC Croix Blandin
18 Rue Léna Bernstein
51100 Reims, France
Tel. +33 3 26 36 31 42
Fax. +33 3 26 09 19 76

SPIROL Germany
Ottostr. 4
80333 Munich, Germany
Tel. +49 89 4 111 905 71
Fax. +49 89 4 111 905 72

SPIROL Spain
08940 Cornellà de Llobregat
Barcelona, Spain
Tel. +34 93 669 31 78
Fax. +34 93 193 25 43

SPIROL Czech Republic
Sokola Tůmy 743/16
Ostrava-Mariánské Hory 70900
Czech Republic
Tel/Fax. +420 417 537 979

SPIROL Poland
ul. Solec 38 lok. 10
00-394, Warszawa, Poland
Tel. +48 510 039 345

Americas SPIROL International Corporation
30 Rock Avenue
Danielson, Connecticut 06239 U.S.A.
Tel. +1 860 774 8571
Fax. +1 860 774 2048

SPIROL Shim Division
321 Remington Road
Stow, Ohio 44224 U.S.A.
Tel. +1 330 920 3655
Fax. +1 330 920 3659

SPIROL Canada
3103 St. Etienne Boulevard
Windsor, Ontario N8W 5B1 Canada
Tel. +1 519 974 3334
Fax. +1 519 974 6550

SPIROL Mexico
Avenida Avante #250
Parque Industrial Avante Apodaca
Apodaca, N.L. 66607 Mexico
Tel. +52 81 8385 4390
Fax. +52 81 8385 4391

SPIROL Brazil
Rua Mafalda Barnabé Soliane, 134
Comercial Vitória Martini, Distrito Industrial
CEP 13347-610, Indaiatuba, SP, Brazil
Tel. +55 19 3936 2701
Fax. +55 19 3936 7121

Asia Pacific SPIROL Asia Headquarters
1st Floor, Building 22, Plot D9, District D
No. 122 HeDan Road
Wai Gao Qiao Free Trade Zone
Shanghai, China 200131
Tel. +86 21 5046 1451
Fax. +86 21 5046 1540

SPIROL Korea
160-5 Seokchon-Dong
Songpa-gu, Seoul, 138-844, Korea
Tel. +86 21 5046-1451
Fax. +86 21 5046-1540

email: info-uk@spirol.com



Please refer to www.SPIROL.co.uk for current specifications and standard product offerings.

SPIROL Application Engineers will review your application needs and work with you to recommend the optimum solution. One way to start the process is to visit our **Optimal Application Engineering** portal at SPIROL.co.uk.