

Non-contacting two-channel speed sensor type FA13 with stainless steel screw-in thread



Scanning type	Non-contacting
Frequency range	FAH[.]: 0.2 ... 20,000 Hz FAJ[.]: See diagram; 5 Hz ...10,000 Hz depending from module and scan distance; under optimal conditions up to 15 kHz
Supply voltage	9 ... 32 VDC
Scanning object - distance	0.2 ... 3 mm; recommended: 1.0 ± 0.5 mm
Protection class	Housing: IP66/IP68/IP69 Connection Type A: IP65; Type C, E, H: IP67; Type X: IP66/IP68
Material	Sensor tube: Stainless steel
Length	L1 = 60 ... 200 mm
Mounting	Male thread M14x1 M16x1.5 M18x1 M18x1.5 5/8" - 18 UNF (not available for all types)
Measuring channels	1 or 2 measuring channels
Output signal and signal type	1, 2 or 4 square wave signals or 2 square wave signals + 1 status signal or 2 square wave signals + 2 inverted square wave signals
Output stage	Push-pull amplifier
Option	Additional status signal Galvanically isolated output signals Inverted output signals



Speed Sensor FA13

Application range

Series FA13 speed sensors are mainly used in the following areas: Shipbuilding industry and machinery and equipment. They usually measure the speed of ferromagnetic toothed wheels. Furthermore, they can be used to measure any movement of ferromagnetic parts, e. g.:

- Toothed wheels with different tooth forms
- Bolt heads
- Holes, openings or grooves
- Impulse bands on plain shafts (accessories)

Specific features

- High quality and robust stainless steel housing: IP66/68/69
- Excellent vibration and shock resistance
- High degree of EMC immunity for difficult electrical environment
- Variable lengths, threads and electrical connections
- Detection of very low speed (near zero speed)
- Due to its design and its approvals especially suitable for shipbuilding industry

Measuring principles

Speed sensors of the FA[.]11 series operate according to different measuring principles, depending on the sensor type:

Difference-hall-effect principle (type FAH11)

Two closely spaced Hall elements are located on the sensor chip. The field of a magnet generates a constant voltage in the Hall elements. Ferromagnetic objects with an interrupted surface as they pass the Hall elements cause the Hall voltage to change. When the moving object covers only one Hall element, a differential voltage is generated to provide a measuring signal. The frequency of this measuring signal is proportional to the speed of movement (rotational speed). The difference-Hall principle is direction sensitive.

Inductive-magnetic principle (type FAJ11)

The measuring element consists of a sensing coil and an iron core with an attached permanent magnet. Ferromagnetic objects with an interrupted surface as they pass cause the constant field of the magnet to be changed and induce a voltage in the sensing coil. The frequency of this signal is proportional to the speed of movement (rotational speed). The inductive-magnetic principle is direction independent.

Overview speed sensors FA13 series

Type	Measuring principle	Signal outputs	Signal form
FAH13	Difference-Hall	One square wave signal	Q1
FAJ13	Induct.-magnetic	One square wave signal	Q1
FAHZ13	Difference-Hall	Two square wave signals, Q2 to Q1 is 90° phase shifted	Q1 Q2
FAHS13	Difference-Hall	Two square wave signals, Q2 to Q1 is 90° phase shifted, one rotation direction signal	Q1 Q2 S
FAHD13	Difference-Hall	Two square wave signals, galvanically isolated, Q2 to Q1 is 90° phase shifted	Q1 Q2
FAHQ13	Difference-hall	Two + two inverted square wave signals, Q1 to Q2 and Q1_N to Q2_N are 90° phase shift	Q1 Q1_N Q2 Q2_N

Approvals						
	FAH13	FAJ13	FAHZ13	FAHS13	FAHD13	FAHQ13
	X	X	X	X	X	X
	X	X	X	X	X	X
	X	X	X	X	X	X
	X	X	X	X	X	X

Dimensions, connections and drawings

Dimensions and mounting drawing

<p>A technical drawing of a sensor shaft. It shows a long cylindrical shaft with a smaller diameter section at the bottom. Dimension L1 is the total length of the shaft. Dimension L2 is the length of the smaller diameter section. Dimension G1 is the diameter of the smaller diameter section.</p>	<p>Explanation to the illustration Please note the possible combinations of L1 and L2 for the nominal length in the type code. L1: 60, 80, 100, 120 mm (up to 200 mm available on request) L2: 5, 20, 40 mm G1: M14x1; M16x1.5; M18x1; M18x1.5; 5/8" – 18 UNF (see type code)</p>
---	--

Direction-sensitive mounting of sensors with difference-hall principle (FAH[..] series)

<p>Two technical drawings of a sensor. The left drawing shows the sensor mounted on a tooth wheel. Dimension A is the distance between the sensor and the tooth wheel. The right drawing shows the sensor with a marker B at the top, which points in the direction of rotation. The rotation angle is indicated as ±15°.</p>	<p>Explanation to the illustration The left figure refers to the "tooth wheel" as scan object. Note that the mounting of sensors with difference-hall principle is direction-sensitive. A: Scan object distance; 0.2 ... 3 mm; recommended: 1.0 ± 0.5 mm B: Marker of sensor (red) Marker (B) points in direction of the tooth wheel rotation. The permissible deviation is max. ±15°.</p>
---	---

Distance and measurable frequency range for sensor with inductive-magnetic principle (FAJ[..] series)

<p>A line graph showing the maximum distance in mm (y-axis, 0.00 to 2.50) versus frequency in Hz (x-axis, 0 to 90). Three curves are shown for different tooth wheel moduli: m1.5 (dashed line), m2 (dotted line), and m3 (solid line). The m1.5 curve shows the highest maximum distance, followed by m2 and then m3. The m1.5 curve starts at approximately 0.2 mm at 0 Hz and reaches 2.50 mm at about 25 Hz. The m2 curve starts at approximately 0.2 mm at 0 Hz and reaches 2.00 mm at 90 Hz. The m3 curve starts at approximately 0.2 mm at 0 Hz and reaches 1.50 mm at 90 Hz.</p>	<p>Explanation to the illustration The left figure refers to the tooth wheel as scan object. The detection of the movement of very small tooth wheels (e. g. m1.5) is possible by reducing the distance between sensor and scanning object. The distance in relation to the lower measurable range is mentioned in the above illustration.</p>
--	--

Connectors and pin assignment

The following table shows an overview about the speed sensors and the available connector types.

Connection type	FAH13	FAHZ13	FAHS13	FAHD13	FAJ13	FAHQ13
DIN43650-A	X	-	-	-	X	-
MIL 14-5PN	X	-	-	-	X	-
EURO M12x1	X	On request	-	-	X	-
DIN72585	X	-	-	-	X	-

Connecting plug -A DIN43650 A

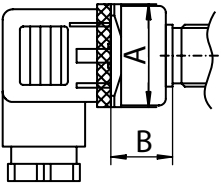
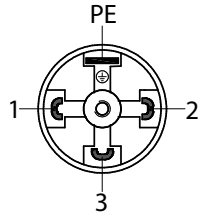
	 <p>Protection class: IP65</p>	<p>Explanation to the left illustration</p> <p>A: Length 30 mm B: Length 18 mm 1: +U_B 2: -U_B (0V) 3: Signal Q PE: Shield</p> <p>Note: On delivery supplied with female connector.</p>
---	---	---

Connecting plug -C MIL 14-5PN

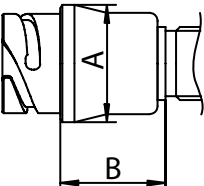
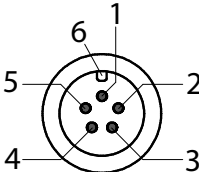
	 <p>Protection class: IP67</p>	<p>Explanation to the left illustration</p> <p>A: Ø 29 mm B: Length 26 mm 1: Shield 2: -U_B (0V) 3: Signal Q 4: Signal Q 5: +U_B 6: Coding nib</p> <p>Note: On delivery without any female connector (accessories set ZL4-1A)</p>
---	---	---

Connecting plug -E Euro M12x1

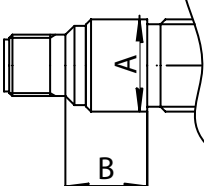
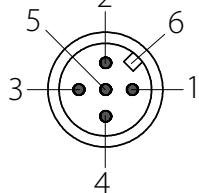
	 <p>Protection class: IP67</p>	<p>Explanation to the left illustration</p> <p>A: Ø 18 mm B: Length 16 mm 1: +U_B 2: not used 3: -U_B (0V) 4: Signal Q 5: Shield 6: Coding nib</p> <p>Note: On delivery without any female connector (accessories set ZL4-2A)</p>
---	---	---

Connecting plug -H1 DIN72585 Bayonet

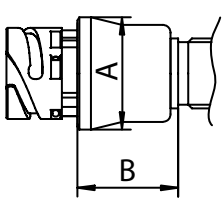
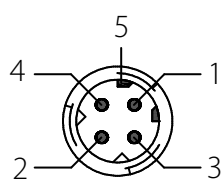
	 <p>Protection class: IP67</p>	<p>Explanation to the left illustration</p> <p>A: \varnothing 29 mm B: Length 26 mm 1: +U_B 2: -U_B (0V) 3: Signal Q 4: Shield 5: Coding nib</p> <p>Note: On delivery without any female connector</p>
---	---	--

List with available female connectors

Connector	Drawing No.	Order No.
Female connector DIN 43650-A	ZL-3A	311046
Female connector according VG95234	ZL4-1A-E	314015
Female connector Euro M12x1, shielded, straight with 2.0 m cable	ZL4-2A	522101
Female connector Euro M12x1, shielded, straight with 5.0 m cable	ZL4-2A	522102
Female connector Euro M12x1, shielded, straight with 10.0 m cable	ZL4-2A	522109
Female connector Euro M12x1, shielded, angled 90°, with 2.0 m cable	ZL4-2A	522439
Female connector Euro M12x1, shielded, angled 90°, with 5.0 m cable	ZL4-2A	522438
Female connector Euro M12x1, shielded, angled 90°, with 10.0 m cable	ZL4-2A	522437

Connection cables and pin assignment

The following table shows an overview about the speed sensors and the related connection cables.

Connection type -X	FAH13	FAHZ13	FAHS13	FAHD13	FAJ13	FAHQ13
Cable with 3 wires	X	-	-	-	X	-
Cable with 4 wires	-	X	-	-	-	-
Cable with 6 wires	-	-	X	X	-	X

Connection cable type -X for sensors with 3 connecting wires

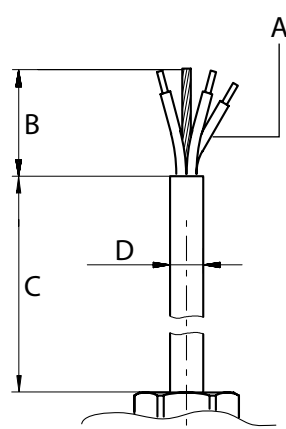
	<p>Explanation to the left illustration</p> <p>A) 3 x 0.33 mm² halogen-free B) 80 ±10 mm C) Length K1 ±5% (K1 see customer drawing) D) \varnothing 4.6 ±0.5 mm</p>
---	--

Connection cable type -X for sensors with 4 connecting wires

	<p>Explanation to the left illustration</p> <p>A) Wires 4 x 0.33 mm² halogen-free B) Length 80 ±¹⁰ mm C) Length K1 ±^{5%} (K1 see customer drawing) D) Ø 7 ±^{0.5} mm</p>
--	---

Connection cable type -X for sensors with 6 connecting wires

	<p>Explanation to the left illustration</p> <p>A) Wires 6 x 0.33 mm² halogen-free B) Length 80 ±¹⁰ mm C) Length K1 ±^{5%} (K1 see customer drawing) D) Ø 7 ±^{0.5} mm</p>
--	---

Connection assignment for type FAH, FAJ (one channel)

Color	Explanation
Brown	U ₅ +
Green	U ₅ - (0V)
White	Signal Q
Shield	Ground

Connection assignment for type FA[.].JZ

Colour	Explanation
Brown	U ₅ +
Green	U ₅ - (0V)
White	Signal Q1
Yellow	Signal Q2
Shield	Ground

Connection assignment for type FA[..]S

Colour	Explanation
Brown	U ₅ +
Green	U ₅ - (0V)
White	Signal Q1
Yellow	Signal Q2
Grey	Status output for direction of rotation detection
Pink	NC
Shield	Ground

Connection assignment for type FA[..]D

Colour	Explanation
Brown	Sensor 1: U _{S1} +
Green	Sensor 1: U _{S1} - (0V)
White	Sensor 1: Signal Q1
Pink	Sensor 2: U _{S2} +
Grey	Sensor 2: U _{S2} - (0V)
Yellow	Sensor 2: Signal Q2
Shield	Ground

Connection assignment for type FA[..]Q

Colour	Explanation
Brown	U ₅ +
White	Q1
Grey	Q1_N, inverted to Q1
Yellow	Q2
Pink	Q2_N inverted to Q2
Green	U ₅ - (0V)
Shield	Ground

Elementary circuit diagrams

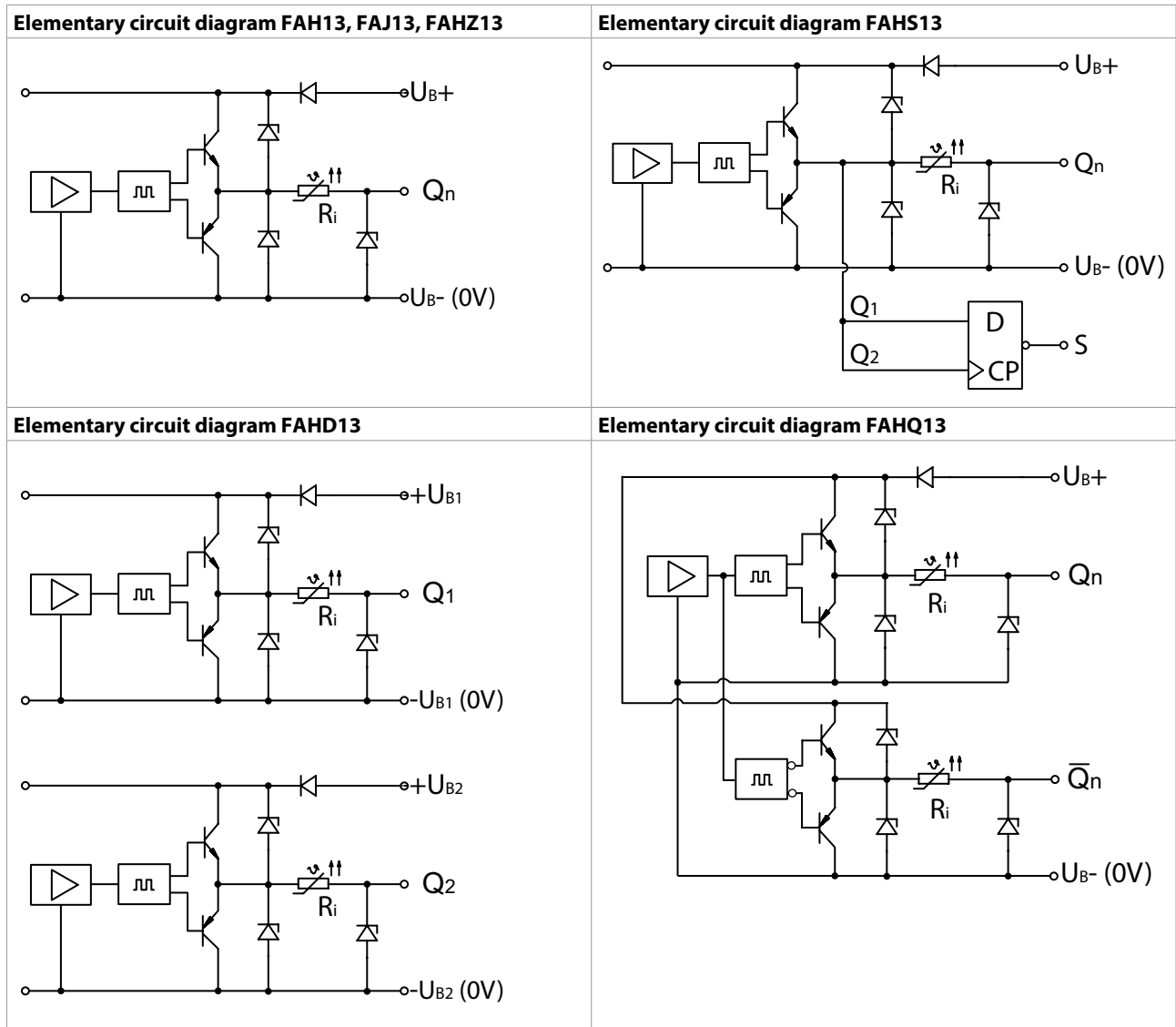

General technical data

Electrical connection	
Supply voltage	See specific technical data
Nominal voltage	See specific technical data
Current consumption	See specific technical data
Reverse voltage protection	Yes
Over voltage protection	Yes
Connection	See specific technical data
Recommended cable length	< 100 m
Used cable cross section	0.33 mm ² , shielded

Electrical output	
Measuring channels	See specific technical data
Output signal and signal type	See specific technical data
Output stage	Push-pull amplifier
Continuous short circuit protection	Yes
Galvanic isolation	See specific technical data
Output level Low	See specific technical data
Output level High	See specific technical data
Output current NPN (Sink)	See specific technical data
Output current PNP (Load)	See specific technical data
Internal resistance Ri	See specific technical data
Rise time	≥ 10 V/μs

Signal acquisition	
Measuring principle	FAH[...] series: Difference-Hall FAJ[...] series: Inductive-magnetic
Frequency range	See specific technical data
Scanning type	Non-contacting
Scanning object - distance	0.2 ... 3 mm; recommended: 1.0 ± 0.5 mm
Scanning object	See specific technical data
Duty cycle	50% ± 10%
Phase shift	See specific technical data

Environmental influences	
Operating temperature	-40 ... +120 °C
Storage temperature	Recommended: -25 ... +70 °C; max.: -40 ... +105 °C (max. limit values within 30 days per year @ relative humidity 5...95%)
Protection class	<i>See specific technical data</i>
Vibration resistance	DIN IEC 60068-T2-6, 10 g @ 5...2000 Hz (Sinus) DIN EN 61373, 30 g @ 20 ... 500 Hz (Random)
Shock resistance	DIN IEC 60068-T2-27, 1000 m/s ² @ 6 ms
Climatic test	DIN IEC 60068-T2-1/-2/-30
EMI - ESD	IEC 61000-4-2, Lev. 3
EMI - Burst	IEC 61000-4-4, Lev. 3
EMI - Surge	IEC 61000-4-5, Lev. 2
EMI - HF immunity	IEC 61000-4-3, 10 V/m IEC 61000-4-6 (RF - conducted), 10 Veff IEC 60553 (AF - conducted), 3 Veff
Emitted interference	CISPR 16-1, CISPR 16-2 EMC2
Insulation voltage	500 VAC, 50 Hz @ 1 min

Mechanical properties	
Material	Sensor tube: Stainless steel Connecting plug: depending on connecting plug type
Mounting	Screw thread (see type code)
Length	L1 = 60 ... 200 mm
Installation position	Any
Installation mode	<i>See specific technical data</i>
Weight	100 ... 300 g (depending on connection and length)
Pressure resistance	5 bar (measuring area)

Specific technical data

Technical data on measuring principles

	Difference-Hall principle	Inductive-magnetic principle
Scanning object	Ferromagnetic materials, Toothed wheel: Module m1 to m3; tooth face > 7 mm (spur gear DIN867) Hole: Ø ≥ 5 mm, web ≥ 2 mm, depth ≥ 4 mm Groove: ≥ 4 mm, web ≥ 2 mm, depth ≥ 4 mm	Ferromagnetic materials, Toothed wheel: Module ≥ m1.5; tooth face width ≥ 5 mm (spur gear DIN867) Hole: Ø ≥ 5 mm, web ≥ 2 mm, depth ≥ 4 mm Groove: ≥ 4 mm, web ≥ 2 mm, depth ≥ 4 mm
Frequency range	0.2 ... 20,000 Hz	See diagram; 5 Hz...10,000 Hz depending from module and scan distance; under optimal conditions up to 15 kHz
Installation mode	Direction sensitive	Direction independent

Technical data on electrical connection and signal detection

Sensors with one measuring channel

	FAH13	FAJ13
Supply voltage	9 ... 32 VDC	
Nominal voltage	24 VDC	
Current consumption	< 10 mA (without output current PNP)	< 6 mA (without output current PNP)
Connection	DIN 43650A, Mil14-5PN, Euro M12x1, DIN 72585 or cable end (see customer drawing)	
Measuring channels	1 measuring channel	
Output level Low	≤ 0.8 V @ 24 VDC, 10 mA, 24 °C	
Output level High	≥ UB-1.5 V @ 24 VDC, 10 mA, 24 °C	
Internal resistance Ri	45 Ω	
Output current NPN (Sink)	max. -50 mA	
Output current PNP (Load)	max. 50 mA	
Protection class	Housing: IP66/IP68/IP69 Connection Type A: IP65; Type C, E, H: IP67; Type X: IP66/IP68	Housing: IP66/IP68/IP69 Connection Type A: IP65; Type C, E, H: IP67; Type X: IP66/IP68
Approvals	CE, ABS, BV, DNV-GL, LR	

Sensors with two measuring channels

	FAHZ13	FAHD13
Supply voltage	9 ... 32 VDC	2 x 9 ... 32 VDC
Nominal voltage	15 VDC	2 x 15 VDC
Current consumption	< 20 mA (without output current PNP)	2 x <10 mA (without output current PNP)
Connection	Cable end, see customer drawing	
Measuring channels	2 measuring channels	2 galvanically isolated measuring channels
Output level Low	Per output: ≤ 0.8 V @ 15 VDC, 10 mA, 24 °C	
Output level High	Per output: ≥ UB-1.6 V @ 15 VDC, 10 mA, 24 °C	
Internal resistance Ri	45 Ω	50 Ω
Output current NPN (Sink)	Per output: max. -50 mA	
Output current PNP (Load)	Per output: max. 50 mA	
Phase shift	90° ± 10% @ m1.5...m3 90° ± 15% @ m1...m1.25	
Protection class	Housing: IP66/IP68/IP69 Connection Type X: IP66/IP68	
Approvals	CE, ABS, BV, DNV-GL, LR	

Sensors with two measuring channels and rotation direction signal

FAHS13	
Supply voltage	9 ... 32 VDC
Nominal voltage	15 VDC
Current consumption	< 20 mA (without output current PNP)
Connection	Cable end, see customer drawing
Measuring channels	2 measuring channels and status channel for rotation direction detection
Output level Low	Per output: $\leq 0.8 \text{ V @ } 24 \text{ VDC, } 10 \text{ mA, } 24 \text{ }^\circ\text{C}$
Output level High	Per output: $\geq \text{UB}-1.6 \text{ V @ } 24 \text{ VDC, } 10 \text{ mA, } 24 \text{ }^\circ\text{C}$
Internal resistance Ri	45 Ω
Output current NPN (Sink)	Per output: max. -50 mA
Output current PNP (Load)	Per output: max. 50 mA
Phase shift	$90^\circ \pm 10\% \text{ @ } m1.5\dots m3 \mid 90^\circ \pm 15\% \text{ @ } m1\dots m1.25$
Protection class	Housing: IP66/IP68/IP69 Connection Type X: IP66/IP68
Approvals	CE, ABS, BV, DNV-GL, LR

Sensors with four output signals

FAHQ13	
Supply voltage	9 ... 32 VDC
Nominal voltage	15 VDC
Current consumption	< 20 mA (without output current PNP)
Connection	Cable end, see customer drawing
Measuring channels	2 measuring channels
Output level Low	Per output: $\leq 0.8 \text{ V @ } 15 \text{ VDC, } 10 \text{ mA, } 24 \text{ }^\circ\text{C}$
Output level High	Per output: $\geq \text{UB}-1.6 \text{ V @ } 15 \text{ VDC, } 10 \text{ mA, } 24 \text{ }^\circ\text{C}$
Internal resistance Ri	45 Ω
Output current NPN (Sink)	Per output: max. -50 mA
Output current PNP (Load)	Per output: max. 50 mA
Phase shift	$90^\circ \pm 10\% \text{ @ } m1.5\dots m3 \mid 90^\circ \pm 15\% \text{ @ } m1\dots m1.25$
Protection class	Housing: IP66/IP68/IP69 Connection Type X: IP66/IP68
Approvals	CE, ABS, BV, DNV-GL, LR

Type code

Type code structure									
FA	H	Z	13-	02	15-	X03-	M10-	S0	Example: FAHZ13-0215-X03-M10-S0
Measuring principle									
Measuring principle supplement									
Construction type & material									
Nominal length L1 and L2 of the sensor tube									
Thread type									
Electrical connection									
Module version									
Shield									

Type code FAJ13[..]									
Measuring principle	J	Inductive-magnetic							J
Measuring principle supplement		Without code: 1 output signal							J
Construction type & material		13-	Sensor tube: Stainless steel						J
Nominal length		02	L1 = 60 mm, L2 = 5 mm						J
		03	L1 = 80 mm, L2 = 5 mm						J
		04	L1 = 100 mm, L2 = 20 mm						
		05	L1 = 120 mm, L2 = 40 mm						
			Other lengths up to 200 mm available on request						
Thread type		13-	M14 x 1						
		22-	M16 x 1.5						
		15-	M18 x 1						J
		23-	M18 x 1.5						J
		88-	5/8" – 18 UNF						
Electrical connection		A-	DIN43650-A pin connector						J
		C-	MIL 14-5PN VG95234 pin connector						
		E-	Euro M12x1 pin connector						J
		H1-	DIN72585 Bayonet						
		X03-	Cable end with sheath length 0.5 m						
		X05-	Cable end with sheath length 2.0 m						J
		X06-	Cable end with sheath length 3.0 m						
		X07-	Cable end with sheath length 5.0 m						
		X08-	Cable end with sheath length 7.5 m						
	X09-	Cable end with sheath length 10.0 m							
Shield			Without code: Shield attached to the sensor housing						J
		S0	Shield not attached to the sensor housing						
FA	__	__	__-	__	__-	__-	__	S0	Example: FAJ13-0323-E-S0

Preferred types

Features marked with an indicator letter in the right column in the table are preferred features. If you select a preferred feature for each placeholder (same indicator letter), the device is specified as a preferred type. Preferred types are available quickly from stock. Other types will be delivered according to scheduled appointments.

Special types

If our standard types do not correspond with your expectations, we are pleased to develop a special solution together with you.

Type code FAH13[...]									
Measuring principle	H	Difference-Hall							X,Z
Measuring principle supplement		Without code: 1 output signal							X
	Z	2 output signal, galvanically connected							Z
	S	2 output signals, galvanically connected with status output (e. g. rotation direction detection)							
	D	2 output signals, galvanically isolated							
	Q	4 output signals (2 + 2 inverted)							
Construction type & material		13 -	Sensor tube: Stainless steel						X,Z
Nominal length		02	L1 = 60 mm, L2 = 5 mm						X
		03	L1 = 80 mm, L2 = 5 mm						X,Z
		04	L1 = 100 mm, L2 = 20 mm						
		05	L1 = 120 mm, L2 = 40 mm						
			Other lengths up to 200 mm available on request						
Thread type		13-	M14 x 1 (FAH13 only)						
		22-	M16 x 1.5 (FAH13 only)						
		15-	M18 x 1						X
		23-	M18 x 1.5						X,Z
		88-	5/8" – 18 UNF (FAH13 only)						
Electrical connection		A-	DIN43650-A pin connector (FAH13 only)						X
		C-	MIL 14-5PN VG95234 pin connector (FAH13 only)						
		E-	Euro M12x1 pin connector (FAH13 only, on request for FAHZ13)						X,Z
		H1-	DIN72585 Bayonet (FAH13 only)						
		X03-	Cable end with sheath length 0.5 m						
		X05-	Cable end with sheath length 2.0 m						
		X06-	Cable end with sheath length 3.0 m						
		X07-	Cable end with sheath length 5.0 m						
		X08-	Cable end with sheath length 7.5 m						
	X09-	Cable end with sheath length 10.0 m							
Module (for FAHD, FAHZ, FAHS, FAHQ Series)		M10-	Module m1						
		M12-	Module m1.25						
		M15-	Module m1.5						
			Without code: Module m2						Z
	M25-	Module m2.5							
	M30-	Module m3							
Shield			Without code: Shield attached to the sensor housing						X,Z
		S0	Shield not attached to the sensor housing						
FA	--	--	--	--	--	--	--	--	Example: FAHZ13-0323-X03-M12-S0

Preferred types

Features marked with an indicator letter in the right column in the table are preferred features. If you select a preferred feature for each placeholder (same indicator letter), the device is specified as a preferred type. Preferred types are available quickly from stock. Other types will be delivered according to scheduled appointments.

Special types

If our standard types do not correspond with your expectations, we are pleased to develop a special solution together with you.