

Data Sheet for Angle Sensors

Hall-Effect Single-Turn Rotary Encoder with PWM Output

Series ETP25



ETP25 - L



ETP25 - K

- PWM output
- Connecting possibilities:
solder lugs or clamping terminal
- Versatile factory programming possibilities

The Series ETP25 can easy installed in the application based on the central thread. The high reliable Hall-Effect technology provides a constant signal quality over the whole life cycle.

Electrical Data

Effective electrical angle of rotation ^{1.)}	$10^{\circ} \leq \alpha \leq 360^{\circ}$ (programmable in factory), $\pm 0.5^{\circ}$
Independent linearity (best straight line) ^{1.)}	$\pm 0.4\% @ 360^{\circ}$
Absolute Linearity ^{1.)}	$\pm 0.6\% @ 360^{\circ}$
Output signal	PWM (pulse width modulation)
Output signal voltage	5V
Carrier frequency	244Hz (constant)
Minimum duty cycle	10%, equal to app. 0.4ms
Maximum duty cycle	90%, equal to app. 3.5ms
Resolution	12Bit
Supply voltage	5 V $\pm 10\%$
Power consumption (no load)	≤ 10 mA
Output load	≥ 5 kOhm
Insulation voltage ^{1.)}	1000 VAC @ 50 Hz, 1 min
Insulation resistance ^{1.)}	2 MOhm @ 500 VDC, 1 min

Mechanical and Environmental Data

Mechanical angle of rotation ^{1.)}	Endless
Lifetime ^{2.)}	> 100 Mio. shaft rotating movements For Option D (with shaft sealing) the sealing is at least working up to 200 000 shaft rotating movements
Bearing	Sleeve bearing
Max. operational speed	100 rpm (800 rpm within short time)
Operational torque without / with X-Ring	$0.1 \leq M \leq 0.6$ Ncm / $0.3 \leq M \leq 1.3$ Ncm (@ RT, 10 rev./min)
Operating temperature range	-40...+85 °C (fixed cable)
Storage temperature range	-40...+105 °C
Protection grade front side (IEC 60529) Standard	IP40
Option D (with shaft sealing)	IP55M, IP66S
Protection grade rear side (IEC 60529) Solder- and clamping terminals	IP40 (solder pads and connectors excluded)
Vibration (IEC 68-2-6, Test Fc)	± 1.5 mm / 20 g / 10 bis 2000 Hz / 16 frequency cycles (3x4 h)
Mechanical shock (IEC 68-27, Test Ea)	50 g / 11 ms / halfsine (3x6 shocks)

Data Sheet for Angle Sensors

Hall-Effect Single-Turn Rotary Encoder with PWM Output

Series ETP25

Max. radial load	1 N
Mass (product with option L)	Approx. 26 g
Fastening parts included in delivery	Hex nut (AF14) and tooth washer, if option D is ordered then an additional O-Ring is part of delivery as sealing between mounting panel and rotary encoder.
Fastening torque mounting nut	≤ 3 Nm
Material shaft	Stainless steel
Material housing	Plastic / Bronze

Immunity

EN 61000-4-2 ESD	Class B
EN 61000-4-3 RF sine wave	Class A
EN 61000-4-6 Conducted sine wave	Class A
EN 61000-4-8 Power frequency magnetic fields	Class A

1.) According IEC 60393

2.) Determined by climatic conditions according to IEC 68-1, para. 5.3.1 without load collectives

Further information

Relationship between anti rotation pin and effective electrical angle

Option anti rotation pin A If shaft flattening is facing antirotation pin A then output signal has 10% duty cycle.

Option anti rotation pin B If shaft flattening is facing antirotation pin B then output signal has 10% of duty cycle.

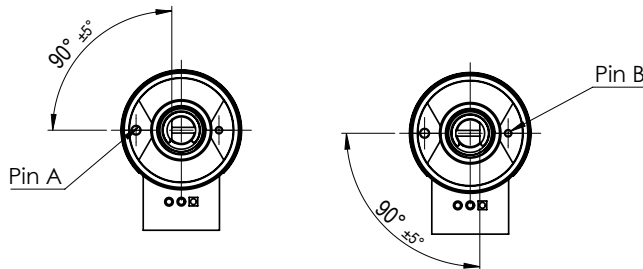

Data Sheet for Angle Sensors

Hall-Effect Single-Turn Rotary Encoder with PWM Output

Series ETP25

Order Code

Description		Selection: standard=black/bold, possible options=grey/cursive							
Series ETP25	ETP25								
Shaft diameter, shaft length: Shaft diameter Ø 6 mm, shaft length 22 mm Option: Shaft diameter Ø 6,35 mm, shaft length 22 mm Option: User defined shaft dimensions [mm] Ø ≤6.35mm		6x22 <i>6,35x22</i> <i>XxXX</i>							
Supply voltage / Output signal: VSUP=5 V (4.5...5.5 V) / OUT=5 V / 244 Hz / PWM 10-90 %				5PWM					
Sense of rotation: Sense of rotation CW (duty cycle I increases clockwise) Option: CCW (duty cycle increases counterclockwise)						CW <i>CCW</i>			
Electrical angle: Electrical angle 360[°] (positive integer) Option: user defined rotation angle (≥ 10°, positive integer)							360 <i>XXX</i>		
Shaft sealing (standard without shaft sealing): Option: D with shaft sealing								<i>D</i>	
Electrical connection, cable length, anti rotation pin (according drawing): Standards: Solder pads (anti rotation pin compatible to former series MAB25A, anti rotation pin A)									LA
Electrical connection, cable length, anti rotation pin (according drawing): Options: Electrical connection: Option: solder pads Option: clamping Terminals Anti rotation pin: Option: anti rotation pin A (anti rotation pin compatible to former series MAB25A) Option: anti rotation pin B (anti rotation pin compatible to former series ENA22A)								<i>L</i> <i>K</i>	<i>A</i> <i>B</i>

Order example ETP25:

Requirement:

Shaft Ø 6.00 mm, shaft length 22 mm, VSUP=5 V / OUT=244 Hz, sense of rotation CW, rotation angle 360°, no shaft sealing, electrical connection solder lugs, anti rotation pin A

Example for order code:

ETP25 6,35x22 5PWM CW 360 LA

Function description PWM signal output ETP25

The rotary encoder ETP25 supplies as output signal 244Hz constant carrier frequency with defined high low ratio. The duty cycle (ratio between high and low value) changes in dependency of the rotation angle. The duty cycle lies between 10% and 90%.

If the option CW is chosen the duty cycle increases clockwise. If option CCW was chosen the duty cycle decreases clockwise. Normally for PWM signals no further processing - for example an external analog/digital converter - is needed, because many micro controllers are equipped with a PWM input.

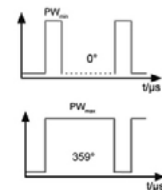

Data Sheet for Angle Sensors

Hall-Effect Single-Turn Rotary Encoder with PWM Output

Series ETP25

Additional options:

For higher quantities or on-going demand, additional options are available as described below on request

For example:

- Special shaft design
- Special cable and connection design
- Special torque

Data Sheet for Angle Sensors

Hall-Effect Single-Turn Rotary Encoder with PWM Output

Series ETP25

Drawing

Option K

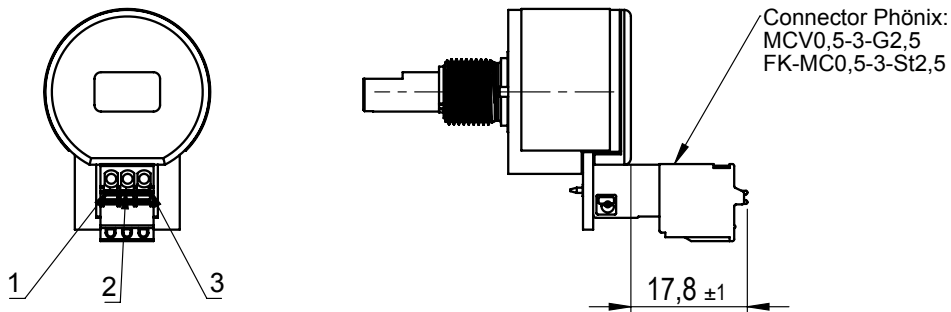

Cable- and Pin-assignment ETP25

Function	Option L and K
OUT	PIN 1
VSUP	PIN 2
GND	PIN 3