

# Adjustable Torque Screwdriver – AMRD / AMLD



Fig.: AMRD4CN

## Micrometer Adjustable Torque Screwdriver for Small Screws (M1-M2)

Tohnichi's AMRD/AMLD series torque screwdriver provides same features as series RTD/LTD, except designed for tightening small screws. Thereby this model is ideal for assembly of watches, precision electronic equipment, computer, etc.

Via micrometer scale torque can easily be adjusted. Index finger holding feature allows the operator to tighten with precise movements. Upon reaching the set torque, it clicks to signal tightening is complete. Integrated rotary clutch mechanism in AMRD series reliably prevents over-torque.

- ▶ Adjustable via engraved micrometer scale.
- ▶ Forefinger grip ergonomics.
- ▶ Standard version releasing in clockwise direction.
- ▶ Accuracy and calibration compliant to EN ISO 6789; type II, class D.
- ▶ Internationally traceable calibration certificate (ISO/JCSS).

## Versions

- ◆ **AMRD:** Once the set torque has been reached, the integrated rotary slip clutch reliably prevents the screw from being overtightened.
- ◆ **AMLD:** Like AMRD, but with a simple click signal instead of a slipping clutch. This makes it ideal for applications that are sensitive to vibration and where the slip clutch vibration could be detrimental.

## Options

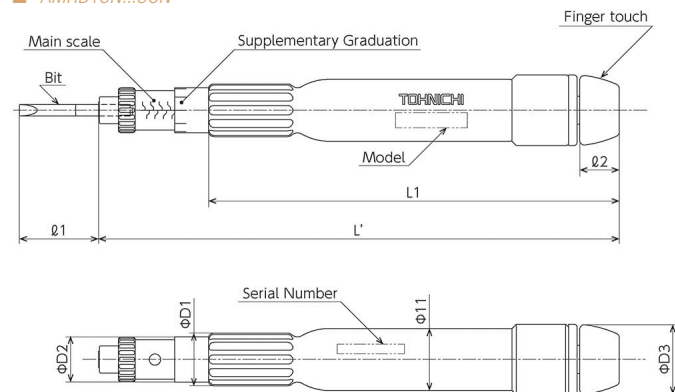
INFO

- Models available in imperial units (ozf-in).
- Models in metric units (gf-cm) on request.

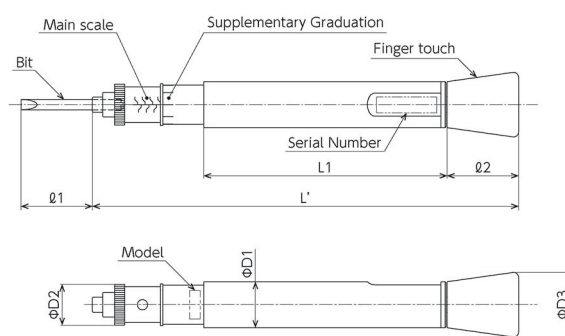


Fig.: AMLD4CN

### AMRD1CN...8CN



### AMLD1CN...8CN



## AMRD (S.I.) – rotary slip

Model	Part No.	Torque Range * cN-m	Grad. cN-m	Applicable Screws		– Dimensions [mm] –						Weight kg	Bit-Insert
				small	tapping	L'	L1	l2	øD1	øD2	øD3		
AMRD 1 CN	T202055	0.3 - 1	0.01	–	–	93	72	8	10	8	13	0.03	ø2
AMRD 2 CN	T202057	0.5 - 2	0.025	M1	–	93	72	8	10	8	13	0.03	ø2
AMRD 4 CN	T202060	1 - 4	0.05	(M1,1) M1,2	M1	93	72	8	10	8	13	0.03	ø2
AMRD 8 CN	T202063	2 - 8	0.1	(M1,4) M1,6	(M1,1) M1,2	93	72	8	10	8	13	0.03	ø2

## AMLD (S.I.) – click type

Model	Item No.	Torque Range * cN-m	Grad. cN-m	Applicable Screws		– Dimensions [mm] –						Weight kg	Bit-Insert
				small	tapping	L'	L1	l2	øD1	øD2	øD3		
AMLD 1 CN	T201075	0.3 - 1	0.01	–	–	83	48	14	9	8	13	0.026	ø2
AMLD 2 CN	T201077	0.5 - 2	0.025	M1	–	83	48	14	9	8	13	0.026	ø2
AMLD 4 CN	T201080	1 - 4	0.05	(M1,1) M1,2	M1	83	48	14	9	8	13	0.026	ø2
AMLD 8 CN	T201083	2 - 8	0.1	(M1,4) M1,6	(M1,1) M1,2	83	48	14	9	8	13	0.026	ø2

\* Table showing specifications by manufacturer. Usage in moderate performance range (approx. 1/3 to 4/5 of rated capacity) is recommended. If you regularly worked close to the limit of load (maximum capacity), a larger model or tool might be more advisable.

