

TYPE	PART NO.	WIRE GAUGE AWG	MATERIAL	REMARK
A	T-7006-B3TT00	18~24	C2680R-H	REEL
A	T-7006-B3TT02	18~24	C2680R-H	LOOSE
B	T-7006-B3TT01	22~28	C2680R-H	REEL
B	T-7006-B3TT03	22~28	C2680R-H	LOOSE

7006T 0.25T*26.4W*11.OP
7006LT

REV	MODIFICATION	DATE	DRAW
B	EN-02-1014	91.10.21	ERICA
C	EN-07-0625	96.06.28	Stacy
D	ECN2-00000200.	2014.01.26	Stacy

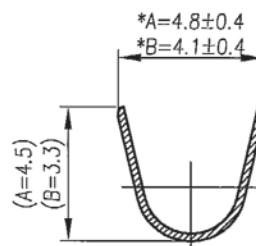
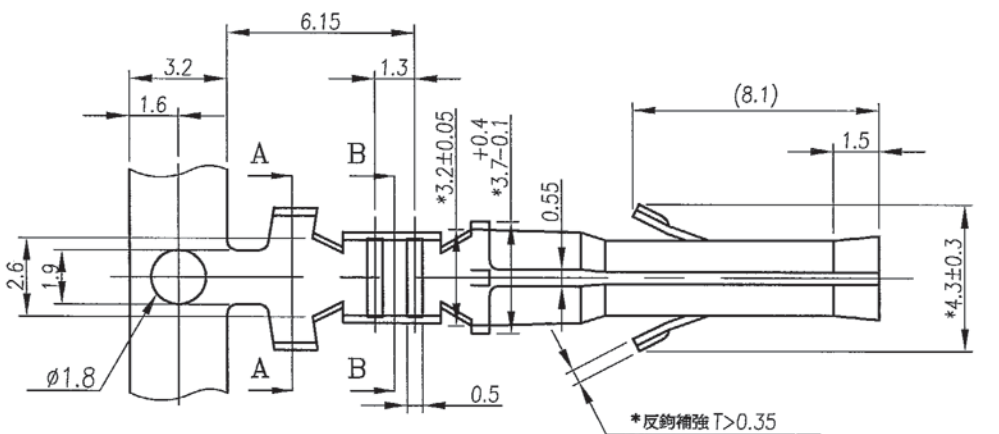

SECTION A-A

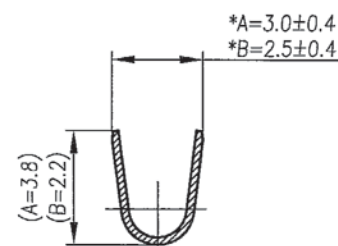

SECTION B-B

*反鉤補強 T>0.35

SPECIFICATIONS:

- CURRENT RATING: 15A AC,DC MAX
- VOLTAGE RATING: 300V AC,DC(SINGLE CIRCUIT: 600V)
- TEMPERATURE RANGE: -25°C TO +90°C (INCLUDING TEMPERATURE RISE)
- CONTACT RESISTANCE: INITIAL VALUE/10mΩ MAX. AFTER ENVIRONMENTAL TESTING/15mΩ MAX.
- INSULATION RESISTANCE: 1000MΩ MIN.
- WITHSTANDING VOLTAGE: 1500V AC/MINUTE
- APPLICABLE WIRE: AWG #24 TO #14,0.2 TO 2.0mm
- APPLICABLE PANEL THICKNESS: .031" TO .079" (0.8 TO 2.0mm)
- CONTACT JST FOR DETAILS.



NOTE:

1.PLATING : Comply to RoHS

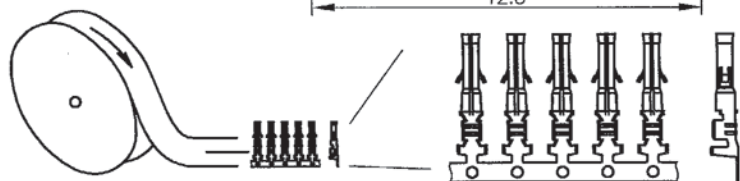
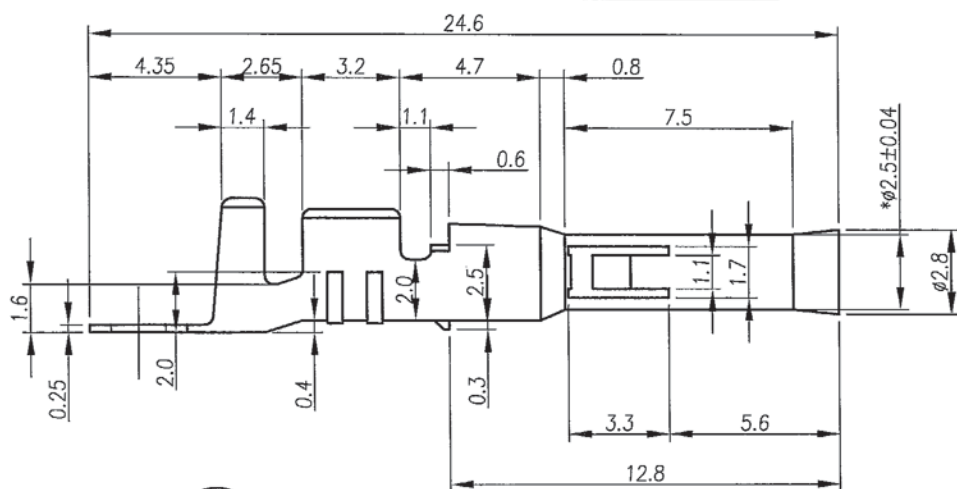

DIMENSION IN mm [Inch]		PROD. SPEC.	KINGFONT PRECISION INDUSTRIAL CO., LTD.	
TOLERANCE UNLESS OTHERWISE SPECIFIED		PKG. SPEC.	7006 CONTACT FOR CRIMPING TYPE	
.X±0.10	X'± 1"	APPROVE <i>Gony</i>	FILE NO.	DWG NO. T-7006-X3TT0X
.XX±0.10	.X'± 0.5"	CHECK <i>Gony</i>	SIZE A4	PROJ. SHEET 1 / 1
.XXX±	.XX'±	DRAW <i>Gony</i>	SCALE 4:1	REV D