

1 2 3 4 5 6 7 8

F

E

D

C

B

A

REV	MODIFICATION	DATE	DRAW

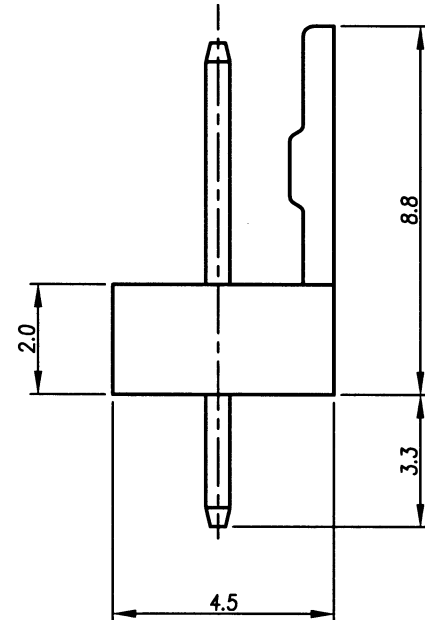
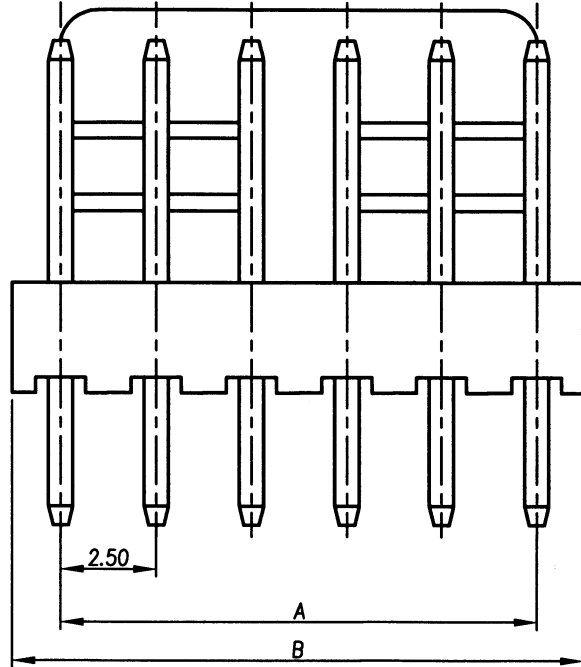

NOTES:  
 MATERIAL: NYLON 66 + BRASS  
 FINISH: TIN PLATED

ORDERING INFORMATION  
 WAFSF-1 XX T1W000  
 PIN NO.

Part No.	Dim. A	Dim. B	Part No.	Dim. A	Dim. B
WAFSF-102T1W000	2.5	5.1	WAFSF-112T1W000	27.5	30.1
WAFSF-103T1W000	5.0	7.6	WAFSF-113T1W000	30.0	32.6
WAFSF-104T1W000	7.5	10.1	WAFSF-114T1W000	32.5	35.1
WAFSF-105T1W000	10.0	12.6	WAFSF-115T1W000	35.0	37.6
WAFSF-106T1W000	12.5	15.1	WAFSF-116T1W000	37.5	40.1
WAFSF-107T1W000	15.0	17.6	WAFSF-117T1W000	40.0	42.6
WAFSF-108T1W000	17.5	20.1	WAFSF-118T1W000	42.5	45.1
WAFSF-109T1W000	20.0	22.6	WAFSF-119T1W000	45.0	47.6
WAFSF-110T1W000	22.5	25.1	WAFSF-120T1W000	47.5	50.1
WAFSF-111T1W000	25.0	27.6			

DIMENSION IN mm [inch]		PROD. SPEC.
TOLERANCE UNLESS OTHERWISE SPECIFIED		PKG. SPEC.
.X±0.25	X'±	APPROVE <i>[Signature]</i>
.XX±0.13	.X'±	CHECK <i>[Signature]</i>
.XXX±	.XX'±	DRAW <i>[Signature]</i>

C  KINGFONT PRECISION INDUSTRIAL CO., LTD.	
TITLE	WAFER CONNECTOR FOR 2.5mm PITCH 180° TYPE WITH BACK
CUSTOMER DRAWING	
FILE NO.	DWG NO. WAFSF-1XXT1W000
SIZE A4	PROJ.  SHEET 1 / 1
SCALE 5:1	REV A

1 2 3 4 5 6 7 8 8F-01-R10 0