

Fig. 3 TROMTRAK 1250

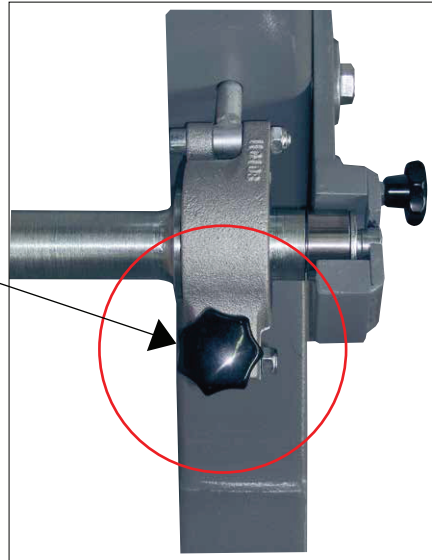

Fig. 4 Brake



Fig. 5 TROMTRAK 1250 with adjustable driving pin

TROMTRAK 1250

The TROMTRAK 1250 is used for the feed of all kinds of winding materials. Its special advantages are the double supported axles as well as the adjustable brake which ensures steady material pay-out.

Application: as supplement for kabelmat® cut-to-length, dismantling or stripping machines.

Being equipped with lockable steering rollers, the device can also be used for transportation of storage area to the processing line.

Basic equipment

- Steel profile frame with 4 lockable steering wheels
- Drum axle with needle bearing, 2 centering cones and adjustable shoe brake
- 2 hand levers for lifting and lowering of the drum

TROMTRAK 1250	Part No. 85100011
drum-Ø	630-1250 mm
drum axle-Ø	Ø 35 mm
drum weight	max. 1000 kg
drum width	max. 890 mm
L x W x H (without drum)	abt. 860 x 1300 x 700 mm
Colour	RAL 7005, mouse grey
Weight	abt. 58 kg

TROMTRAK 1250 with adjustable driving pin	Part No. 85100851
drum-Ø	630-1250 mm
drum axle-Ø	Ø 35 mm
drum weight	max. 1000 kg
drum width	max. 810 mm
driving pin-Ø	25 mm
L x W x H (without drum)	abt. 860 x 1300 x 700 mm
Colour	RAL 7005, mouse grey
Weight	abt. 60 kg