

- **Compact and robust design for machines and systems, especially for construction machines, underwater devices and food processing machines**
- **Digital or analogue interfaces**
- **High vibration and shock resistance thanks to robust mechanical design and additional casting within the housing**
- **Housing: aluminium or stainless steel**
- **Dual-chamber system for separating the rotor and electronics**
- **Resolution: 4096 steps / 360°, (12-bit binary) (13-bit optional)**
- **Protection types: IP66 (IP 69K optional)**
- **Operating temperature range: -40 °C to +85 °C**

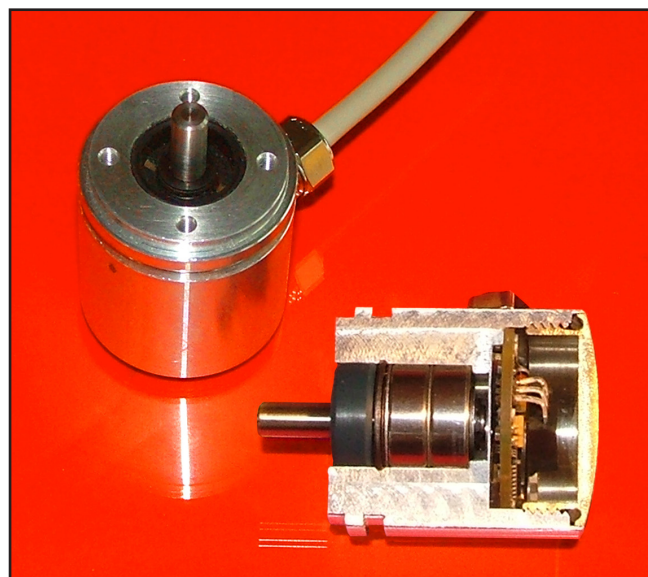

Design

Robust aluminium or stainless steel housing (wall thicknesses up to 5 mm) - stainless steel shaft and ball bearing - ball bearing with Simmer ring, rotor with shaft and permanent magnet mounted in pre-chamber - sensor circuit consisting of ASIC with Hall elements and interface electronics in enclosed main chamber - housing protection type IP 69K additionally cast - electrical connection via cable (open cable ends).

Electrical interfaces

- **Model TBE 36: Synchronous-serial SSI (Page 2)**
- **Model TBI 36: Incremental (Page 3)**
- **Model TBN 36: CANopen (Page 4)**
- **Model TBA 36: Analogue (Page 5)**

Mechanical data for all models

- Operating speed: 1000 rpm max.
(optionally up to 10,000 rpm)
- Angular acceleration: 10⁵ rad/s² max.
- Moment of inertia (rotor): 20 gcm²
- Operating torque: ≤ 8 Ncm
(at 500 rpm)
- Starting torque: ≤ 4 Ncm
- Perm. shaft load: 100 N axial
100 N radial
- Bearing service life: ≥ 10⁹ revolutions
- Mass: Approx. 0.150 kg

Dimensions, materials and accessories: Page 6

Electrical data for all models

- Sensor system: ASIC with Hall elements
- Meas. step deviation: ± 0.5 LSB
- EMC standards: EN 50081-2, EN 50082-2

Environmental data for all models

- Operating temp. range: - 40 °C to + 85 °C
- Storage temp. range: - 20 °C to + 60 °C
(due to packaging)
- Resistance:
 - To shock: 500 m/s²; 11 ms
DIN EN 60068-2-27
 - To vibration: 10 Hz ... 2000 Hz; 500 m/s²
DIN EN 60068-2-6
- Protection types
(DIN EN 60529): IP 66
IP 69K on housing side (optional)

- Connection assignments are supplied with the absolute encoders.



Model TBE 36: Synchronous-serial interface -12-bit / 360°

Function

The absolute angle information present in the absolute encoder is serially and synchronously transmitted to the receiver electronics within one cycle. The essential advantages of this are the low number of data cables and extensive protection against interference (an exhaustive description is contained in TWK's SSI 10630 pamphlet).

Maximum data rates

- The data rate is limited by the following variables:
 - Clock frequency: Max. 1 MHz (up to approx. 40 m)

- Overall electronics delay (between approx. 40 m and approx. 150 m)

$$t_{GV} = t_C + 2t_K + t_E$$

t_{GV} : Overall delay time

t_C : Delay time of the coding electronics (here e.g. ≤ 300 ns)

t_K : Delay time of the cable (depending on the cable length and typ. speed e.g. 6.5 ns/m)

t_E : Delay time of the reception electronics (e.g. 150 ns)

A safety distance of 50 ns between the cycle duration of the cycle t_T and the delay time of the overall electronics t_{GV} results in:

$$t_T = 500 \text{ ns} + 2t_K$$

- According to RS 422 specifications (as of approx. 150 m)

The adjacent limit value curve is e.g. therefore obtained with the above specified values.

Principle circuit diagram

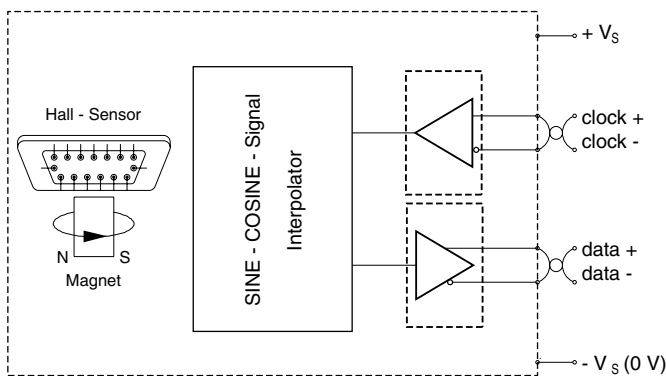

Interface profile SSI - 13-bit / binary

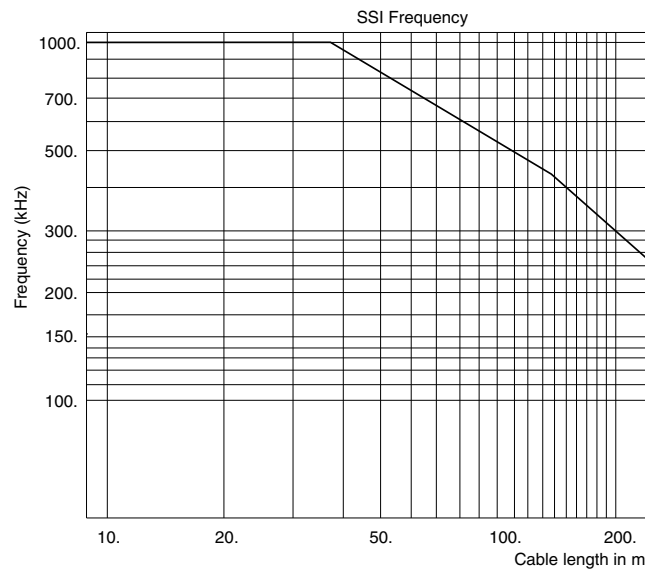
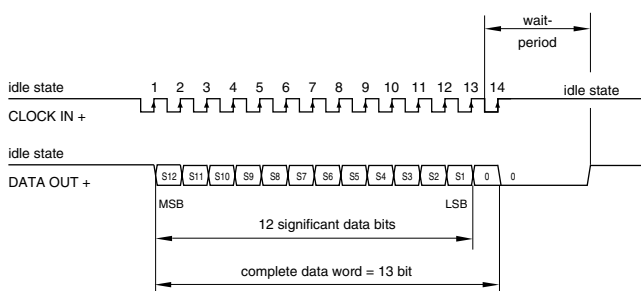

Electrical data

- Operating voltage range: + 11 VDC to + 26 VDC
- Operating current: 50 mA typ. / 80 mA max.
- Resolution (standard): 4096 steps / 360° (12 Bit) (8192 steps / 360°, optional)
- Output code: Binary
- Code path: CW (CCW optional)
- Serial output SSI: Differential data output (RS 422)
- Clock input SSI: Differential data input (RS 422)
- Monoflop time: 16 ± 10 μs (standard)
- Clock rate: Max. 1 MHz

Order numbers

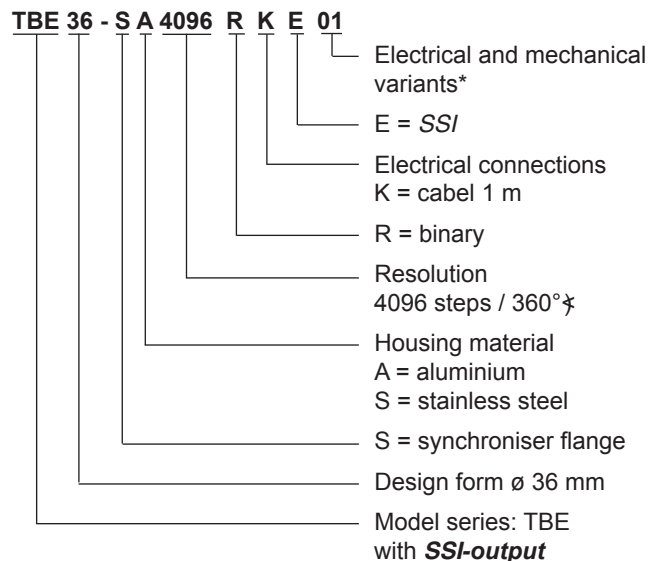

* The basic versions according to the data sheet bear the number 01. Deviations are identified with a variant number and are documented in the factory.

Model TBI 36: Incremental outputs

Electrical data

- No. of pulses (standard): 1024 pulses/revolution
- Outputs: Channels A, B and zero plus the inverted signals
- Signal form: Square pulses
- Signal form: Square pulses

1	10	32	80	200	500
2	16	40	100	250	512
4	20	50	125	256	1024
8	25	64	128	400	2048

Principle circuit diagram

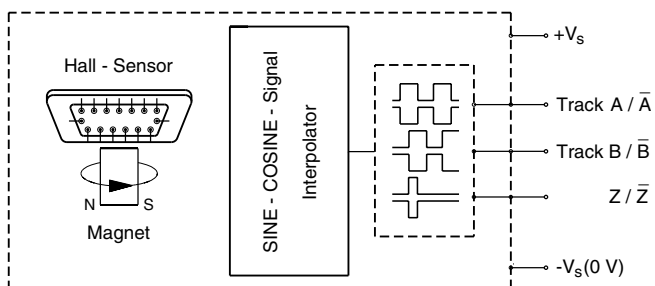

Signal output with CW rotation (looking at the shaft)

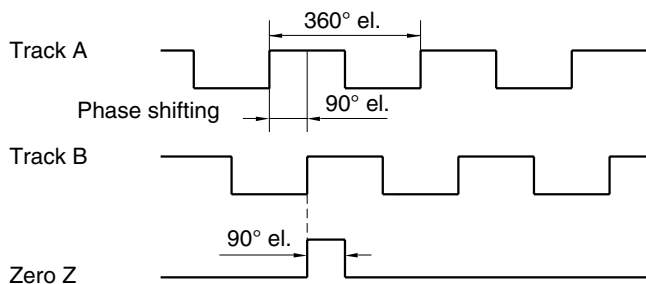

Signal definitions

Signal forms	D	T*	U
Operating voltage range U_B	11 bis 26 VDC	5 VDC \pm 5 %	11 bis 26 VDC
Signal current I_A	20 mA	20 mA	5 mA
Signal level high	$U_B - 3$ VDC	> 2,8 VDC	> 2,8 VDC
Signal level low	< 5 VDC	< 0,5 VDC	< 0,5 VDC
Max. pulse frequency	Max. 250 kHz		
Duty cycle	1:1 \pm 30 %		
Phase offset	90° \pm 30 %		
Zero pulse length	90° (others on request)		
Direction of rotation	CW (standard)		
* RS 422-compatible			



Order numbers

TBI 36 - S A 1024 K D 01

- Electrical and mechanical variants*
- Output signals (nominal)
D: $V_s = 24$ V und $U_o = 24$ V
T: $V_s = 5$ V und $U_o = 5$ V
U: $V_s = 24$ V und $U_o = 5$ V
- Electrical connections
K = cable 1 m
- 1024 pulses / revolution
- Housing material
A = aluminium
S = stainless steel
- S = synchroniser flange
- Design form \varnothing 36 mm
- Model series: TBI with **incremental output**

* The basic versions according to the data sheet bear the number 01. Deviations are identified with a variant number and are documented in the factory.

Model TBN 36: CANopen interface - 12 bit / 360°



Electrical data

According to CANopen Application Layer and Communication Profile, CiA Draft Standard 301, Version 4.1 and according to "Device Profile for Encoders CiA Draft Standard Proposal 406, Version 3.0" and CANopen Layer setting Services and Protocol (LSS), CiA DSP 305.

- Operating voltage range: + 11 VDC to + 26 VDC
- Operating current: 50 mA typ. / 80 mA max.
- Resolution: 4096 steps / 360°* - (12 bit) (13 bit optional)
- Output code: Binary
- Code path: CW / CCW
- Reference value: 0 - (total No. of steps -1)
- CAN-interface: According to ISO/DIS 11898
- Address setting: Via SDO / LSS
- Terminating resistor: To be implemented separately
- Max.transmission length: 200 m *

* No galvanic separation between supply voltage and bus lines (also see CiA DS301).

CANopen Features

- NMT Master: no
- NMT-Slave: yes
- Maximum Boot up: no
- Minimum Boot up: yes
- COB ID Distribution: Default, SDO
- Node ID Distribution: via Index 2000 oder LSS
- No of PDOs: 2 Tx
- PDO-Modes: sync, async, cyclic, acyclic
- Variables PDO-Mapping: no
- Emergency Message: yes
- Heartbeat: yes
- No. of SDOs: 1 Rx / 1 Tx
- Device Profile: CiA DSP 406 Version 3.0

The details of the profile are exhaustively described in the TXN 11551 user manual.

Principle circuit diagram

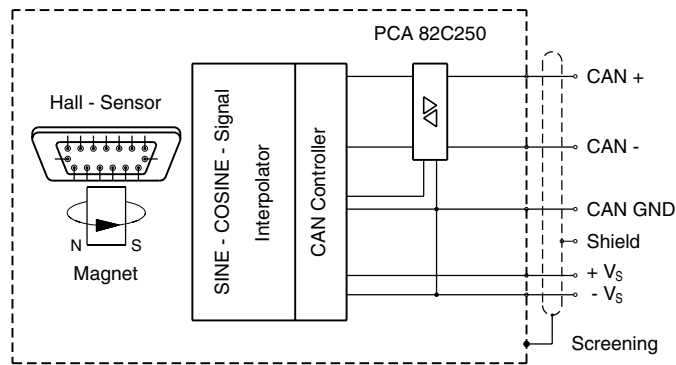

Bus activation according to ISO / DIS 11898

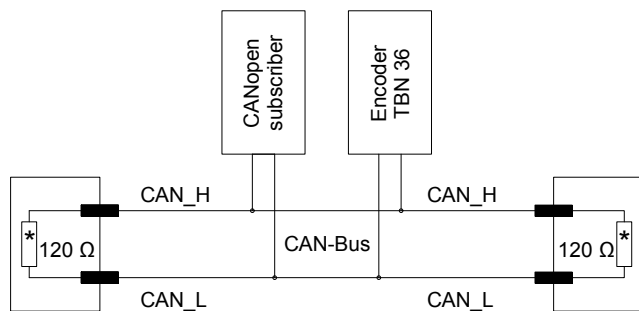

*Terminating resistor

CANopen data format

PDO 1

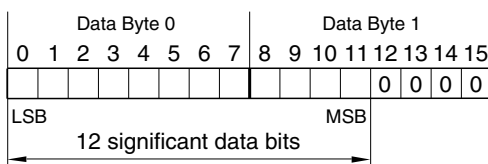

Order numbers

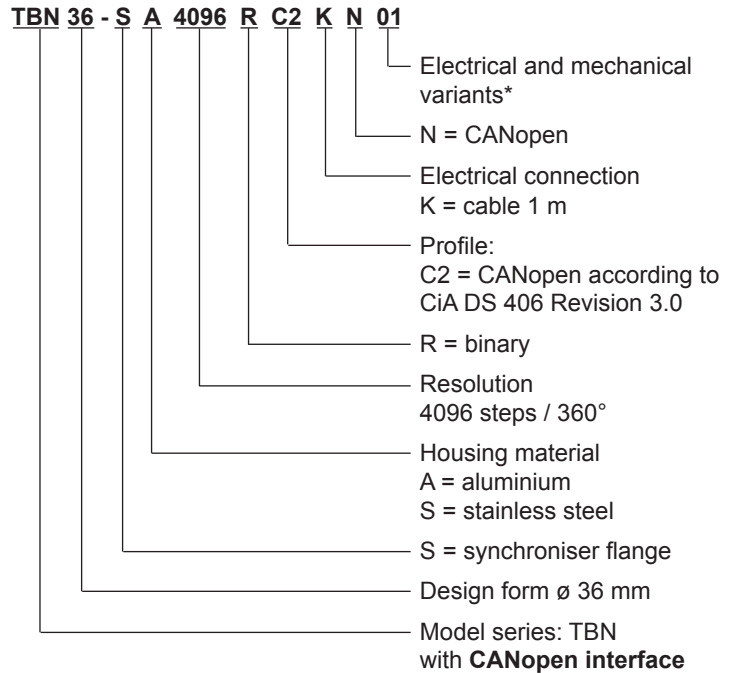

* The basic versions according to the data sheet bear the number 01. Deviations are identified with a variant number and are documented in the factory.

Model TBA 36: Outputs 0-20 mA, 4-20 mA, 0-10 VDC or ±10 VDC

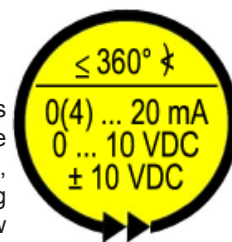

In order to record mechanical variables such as angles, rotary movements or positions, the contactless electromagnetic sensor system is extended with a 12-bit (360° measuring angle) D/A converter so that the measured variable is available as an analogue signal from 0 (4) to 20 mA, 0 to 10 V or ± 10 VDC. - As standard, the encoders are designed for a measuring angle of 360°. At the request of the customer, other measuring angles can also be set with the specified output signals in the factory. A symmetrical overflow / underflow value is output outside of the measuring range (see characteristic curve).

Characteristic curve: measuring angle 262° as an example

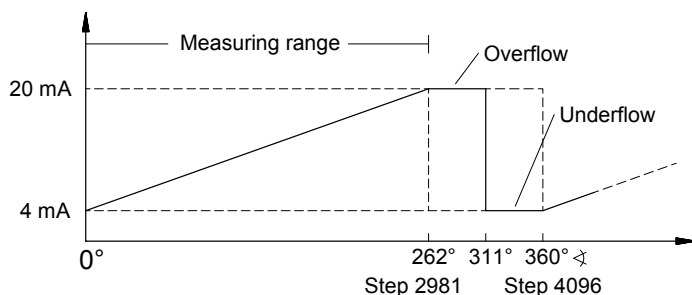

Electrical data

- Resolution for 360°: 12-bit
- Meas. angle (standard): 360° (90° or 180° optional, other angles on request)
- Outputs:
 - A: 0 to 20 mA
 - B: 4 to 20 mA
 - C: 0 to 10 VDC
 - D: ± 10 VDC
- Signal path: CW (CCW optional)
- Zero point shift: Optional
- Operating voltage: 20 to 28 VDC (output: A, B, C) ± 13 to ± 16 VDC (output D)
- Operating current: 50 mA typ. / 60 mA max.
- Linearity: ≤ 0.5 %
- Reproducibility: ≤ 0.2 %
- Temperature drift: < 0.01 % / ° K / typ.

Current output

- Accuracy
 - Minimum value 0 mA: 0 mA ± 50 µA
 - 4 mA: 4 mA ± 50 µA
 - Maximum value 20 mA: 20 mA ± 50 µA
- Load resistance (burden): 0 ... 500 Ω (V_S = 20 ... 28 VDC)

Voltage output

- Accuracy
 - Minimum value 0 V: 0 V + 0.1 V with output 0 - 10 V
 - 0 V ± 25 mV with output ± 10 V
 - Maximum value 10 V: 10 V ± 25 mV
 - ± 10 V: ± 10 V ± 50 mV
- Output current: Max. 5 mA (short-circuit-proof) acc. to load resistance > 2 kΩ

Prinzipschaltbild

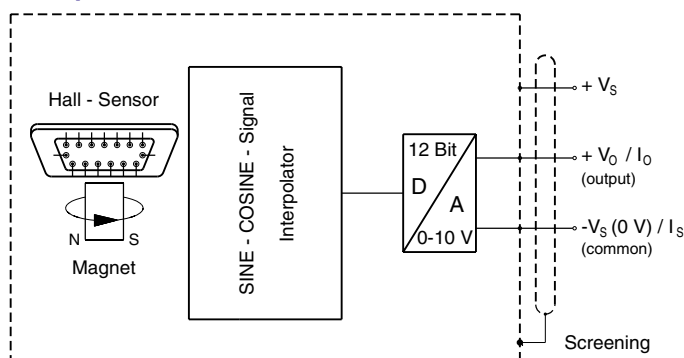

Order numbers

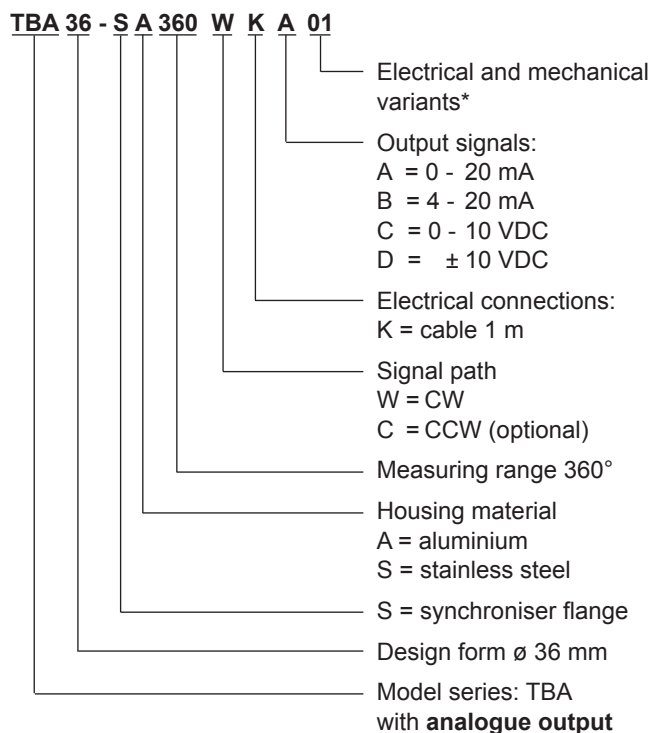

* The basic versions according to the data sheet bear the number 01. Deviations are identified with a variant number and are documented in the factory.

Dimensions in mm

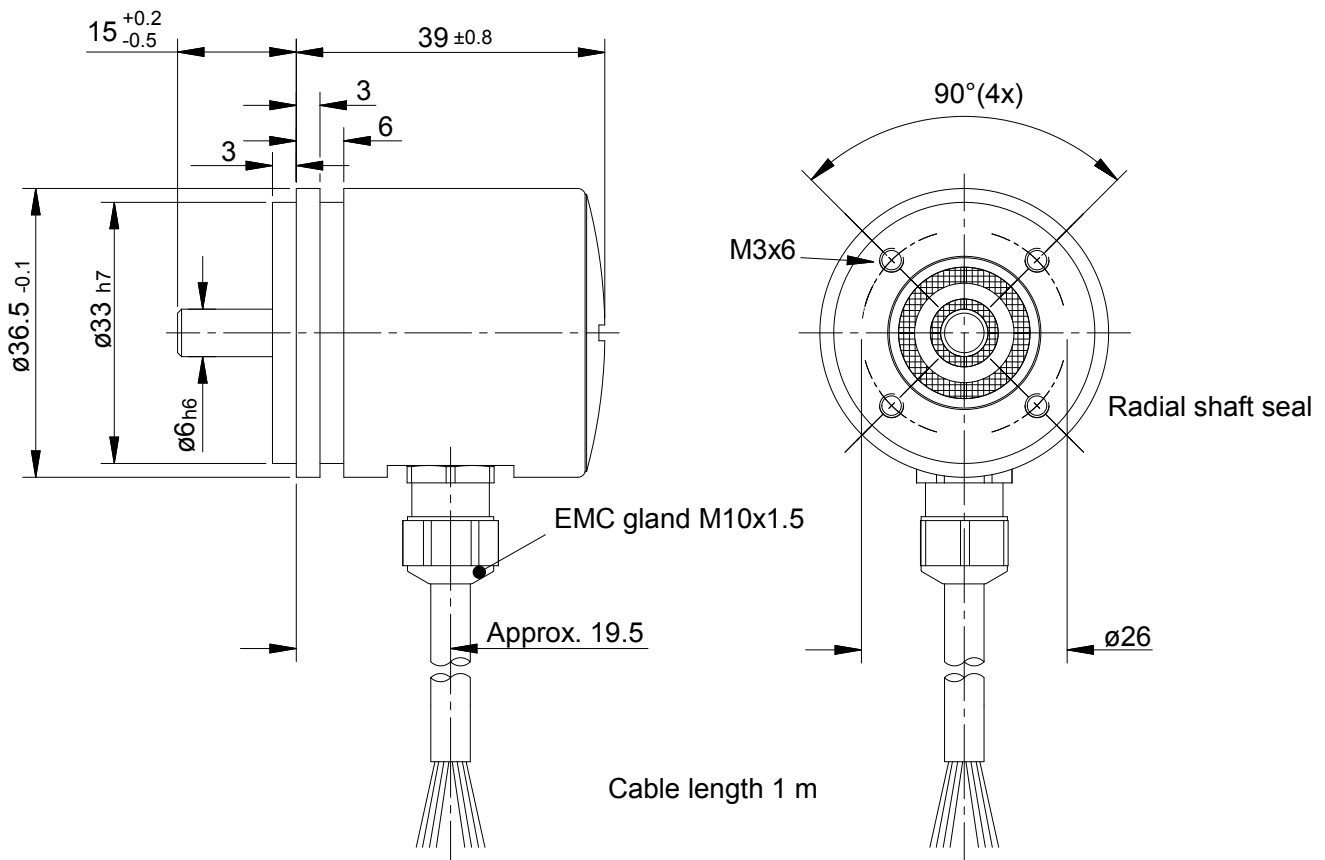

Materials used

Aluminium housing:	AlMgSi1
Stainless steel housing:	1.4305
Stainless steel shaft:	1.4305
Housing cover:	Nickel-plated PA/Ms
Threaded cable connection:	Nickel-plated PA/Ms
Simmer ring:	NBR
Sealing rings:	NBR

B Series KL 66-2 securing clamps

<input type="checkbox"/> Pitch diameter:	$51^{+0.5}$ mm	<p>Countersink DIN 74 Bm4</p> <p>Dimensions: $\varnothing 14.5$, $\varnothing 12$, 5.2, 2.6, 5.2</p>
<input type="checkbox"/> Material:	Nickel-plated brass	
<input type="checkbox"/> Required screws:	4 countersunk head with hexagon socket DIN 7991	
<input type="checkbox"/> (units each required)		