

||||| ROTAMAT |||||



THE ROTAMAT

The ideal solution for coating of mass-produced small parts



The Rotamat – a coating system with unlimited possibilities

DECORATIVE COATING

Surface refinement with a multitude of decorative and functional paints, eco-friendly paints without solvent and single- or two-component special paints.



Decorative coating of plastic



Decorative coating of wood



Decorative coating of metal components

COATING WITH ANTI-BLOCKING AGENTS

Reduces friction and prevents juddering and stick-slip effects on small components like O-rings, sealing components or valve stems. Anti-blocking coatings also facilitate the separation of work pieces.



Anti-blocking coating of gaskets



Anti-blocking coating of O-rings

COATING FOR ELECTRICAL INSULATION

Special paints provide an insulating protective coating on electronic components – for example, on ferrite cores, ferrite rings and capacitor casings.





COATING WITH A BONDING AGENT

Creates a strong bond between the substrate and the elastomer. Available as single or double layer systems consisting of primer and cover.



Application of bonding agent on half-shells



Application of bonding agent on shaft seal rings



Application of bonding agent on metal sleeves

COATING FOR CORROSION PROTECTION

Places a protective coating on the work pieces without hazardous chemicals. For example, compared to dip spin coating, the helical thread of small and micro screws remains open and smooth.



Corrosion protection coating of screws



Corrosion protection coating of metal components

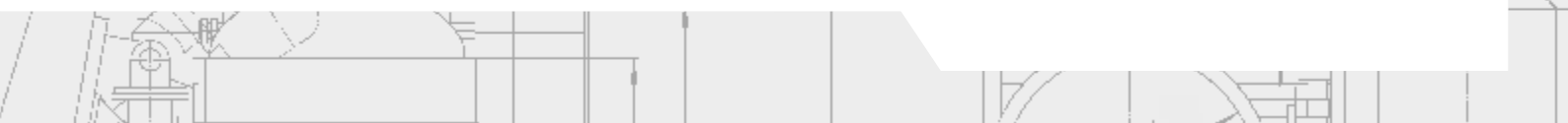



Efficient and cost effective coating of mass-produced small parts



Glimpse into the spraying chamber

The Rotamat technology for coating of small parts is a so-called “hot drum” system with the coating process taking place in a closed spraying chamber.

In this highly efficient and cost effective system a batch of raw, uncoated work pieces is placed into a rotating drum located in a protective housing. One, respectively, two automatic spray guns are evenly applying the coating material on the work pieces, which are continuously tumbling over each other. The work pieces can be made of various plastic materials, elastomers, metals or wood. Water-based as well as solvent-based paints can be utilized in the Rotamat systems.

It goes without saying that when solvent-based coating materials are used, the legal corrosion protection requirements are fully met.

The required work piece temperature specified for a given coating process is achieved by pre-filtered fresh air that is heated in a special heating unit and controlled by an IR sensor.



IR sensor for measuring the work piece temperature

The paint is applied with a minimum of overspray and dries quickly on the heated work pieces creating a visually highly homogeneous surface. Upon completion of the coating process the painted work pieces can be easily and quickly unloaded by mechanically tilting the drum downwards. They are immediately available for the next manufacturing stage without the need for a post-drying step, for example, in an oven.

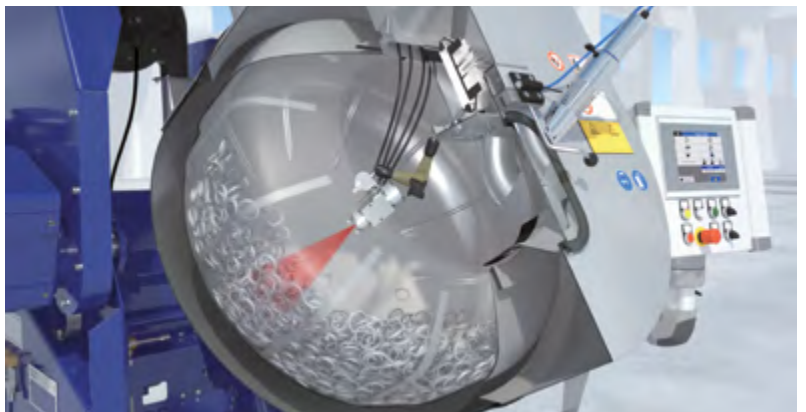

Coating process in a Rotamat system



THE DRUM

In order to achieve perfect coating results the work pieces must be tumbling continuously. Important is that the particular tumbling characteristics of the different work pieces are taken into account. The special drum geometry, the infinitely adjustable rotary drum speed and tilting angle generate the optimal tumbling and mixing characteristics of the work pieces. The coating process itself is fully automatic. The costly and time-consuming placement of the work pieces on special racks – as required with conventional coating systems – has been completely eliminated.

For optimal edge protection of complex, large work pieces the inside of the drum can be equipped with a special protective lining.

The drums can be easily exchanged and are available in five different sizes/ diameters:

Ø 550 mm	2–8	liters/batch
Ø 600 mm	5–15	liters/batch
Ø 700 mm	10–30	liters/batch
Ø 800 mm	30–50	liters/batch
Ø 850 mm	40–75	liters/batch

THE SPRAYING SYSTEM

The Rotamat systems are coating the work pieces in a closed spraying chamber at a slight, adjustable negative pressure. This prevents hazardous and harmful gases from escaping.

All settings in the Rotamat systems like the spraying rate, the spray pattern (wide or round pattern), etc., are managed by the system controls thus guaranteeing a high degree of process stability with absolutely repeatable coating results.

The use of special HVLP automatic spray guns ensures paint applications with a minimum of spray mist and, therefore, very little, overspray.

INTERIOR LIGHTING OF THE DRUM

The drum lighting provides a complete view of the spraying chamber and allows the operator to monitor the coating process from the outside.



Loading of the drum with O-rings



Automatic spray gun



Interior lighting of the drum



INLET AND EXHAUST AIR SYSTEM

To bring the work pieces to their optimum temperature, warm and turbulence-free air is guided into the rotating drum during the entire coating process. The work piece temperature is directly measured and controlled by an IR sensor on a continuous basis. The air temperature and air volume are not only determined by the work piece material, geometry and type but also by the respective paint specifications. The injected air ensures that the volatile materials generated during the drying process are safely removed from the system.

The pre-set negative pressure in the drum is maintained fully automatically, independent from the dust load in the integrated air filter.

SYSTEM CONTROLS

An industrial PC with touch panel, integrated into the control cabinet, automatically monitors and controls all process parameters like air volume, air temperature, drum speed and spraying rate. This ensures that the coating results are absolutely repeatable. Of course, the operator can override the programmed coating parameters if needed.

The recipe administration module in the PC manages all recipes generated for the various coating applications allowing their quick recall and use. With the integrated report management module all process parameters for every single work piece batch run in the past can be recalled for review.

THE EXHAUST AIR FILTER CABINET

The filter cabinet contains four filter stages, one Papp labyrinth filter, a filter mat and two pocket filters. The filter cabinet can be easily disconnected and can, therefore, be quickly exchanged.

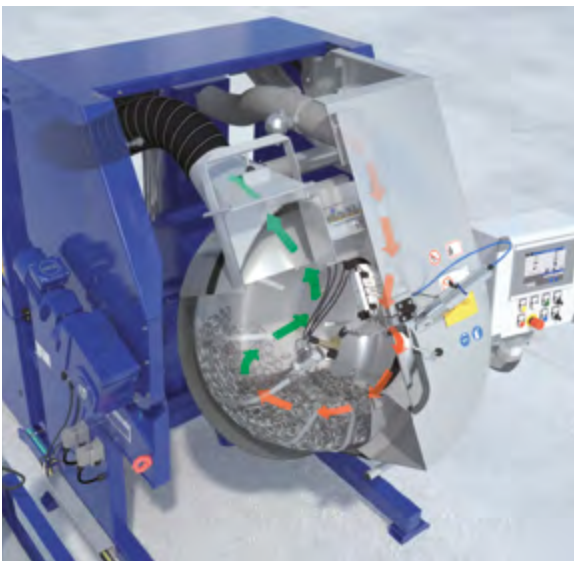

Inlet and exhaust air system: Red arrows: heated air; green arrows: Exhaust air



Filter cabinet; can be equipped with disconnect option



The Rotamat control cabinet with built-in industrial PC



ACCESSORIES

PAINT PRESSURE VESSELS

To achieve an even, homogeneous spray pattern, the coating material must be transported without any pulsation. For this purpose special pressure vessels in different sizes, up to 45 liters, are utilized. Extra features like lid lifts, rinsing systems, etc., can also be supplied.

COLD AIR GENERATOR

For some paint applications requiring very high temperatures in the rotating drum, it may become necessary to cool the coating material to prevent blockages in the supply line.

DRUM CLEANING DEVICE

After a certain number of coating cycles (depending on the coating process), the drum should be cleaned to remove any paint residues. The dismounted drum is simply clamped into a cleaning station, where with the help of Trowal cleaning media all paint residues are removed from the drum walls.

AUTOMATIC SPRAY GUNS

Walther Trowal uses HVLP automatic spray guns working with low mist atomization and a large spraying angle. This allows the optimal coating of the work pieces with a minimum of overspray. A special adapter plate allows quick exchange of the spray guns without having to loosen the hose connections.

The Rotamat can be equipped with one or two spraying systems. For example, this allows consecutive coating with two different paint types without any interruption whatsoever. Alternatively, parallel coating with both systems is possible.

CONDITIONING OF THE INLET AIR

For certain applications it may become necessary to control the humidity of the air in the rotating drum. Humidifying or de-humidifying devices can be supplied if needed.

3S COATING OF THE ROTATING DRUM

For very delicate work pieces, which could be damaged during the tumbling process, the inside of the stainless steel drum can be lined with relatively soft, protective material. Another benefit of such a lining is that paint residues can be easily removed.

SCALE

The use of a scale allows the precise application of a pre-set paint quantity. The automatic scale not only controls the sprayed quantity but also measures the remaining paint quantity in the pressure vessel.



Drum with 3S lining



Scale with paint pressure vessel





Rotamat R 60

Usable volume 2 to 15 liters, respectively max. batch weight 25 kg. Manual tilting of the drum.



R 60 in working position with closed drum cover



Drum in discharge position and discharge table



Loading of the drum with uncoated work pieces



Discharge of the coated work pieces





Rotamat R 80

Usable volume up to 50 liters, respectively max. batch weight 50 kg.
Mechanical tilting of the drum with electric motor.



R 80 in working position with closed drum cover



R 80 with open drum cover



Drum exchange



Optional sound enclosing cabin with air extraction system



Rotamat R 90 C

Usable volume up to 75 liters, respectively max. batch weight 100 kg. Mechanical tilting of the drum with electric motor. Two-hand safety operation for opening of the drum cover.



R 90 C with closed drum cover



R 90 C with open drum cover

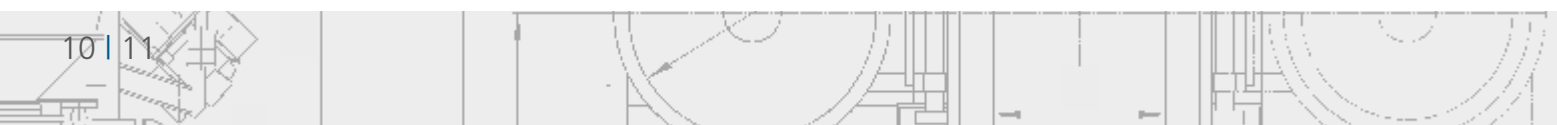



Technical Data

ROTAMAT	R 60	R 80	R 90 C
Drum tilting angle in °	25–35	24–36	23–37
Compressed air, dry and free of oil in MPa	0,6+/-0,1		
Power input in KVA	19		
Voltage	400 V, 50 HZ		
DRUM			
Diameter in mm	600	800	850
Usable volume max. in l	15	50	75
Batch weight max. in kg	25	50	100
Drum speed in m ⁻¹	2 ... 30		
Protective fuse in A	35		
INLET AIR SYSTEM			
Air volume max in m ³ /h	160		
Filter class to EN 779	G4		
Heating performance in kW	9		
Inlet air temperature max. in °C	150		
EXHAUST AIR SYSTEM (4 stages)			
Air volume max in m ³ /h	200		
Filter class to EN 779	F6		
DIMENSIONS			
A: Depth in mm	2.080	2.400	2.490
B: Width in mm	1.250	1.450	1.920
C: height in mm	2.010	2.100	2.020

Dimensions of the control panel: 1.400 x 500 x 2.000 L x W x H in mm

USABLE DRUM VOLUMES

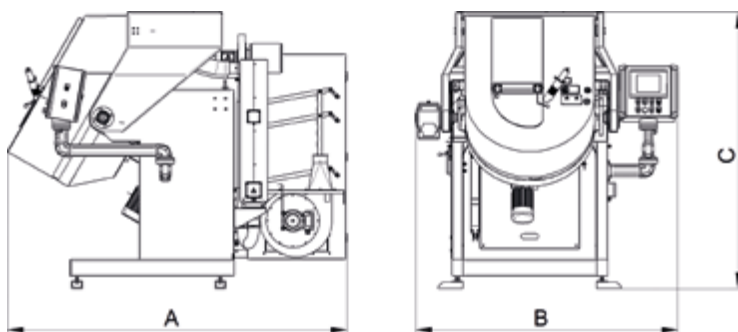
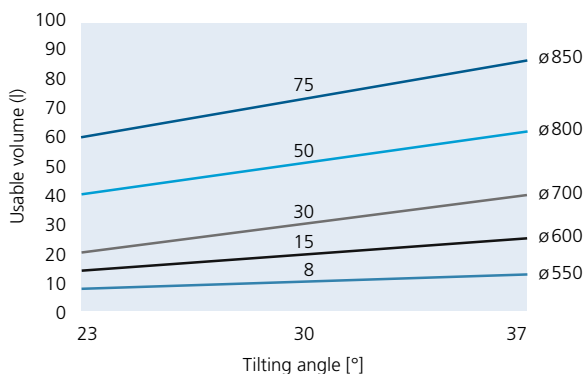



WAL THER
TROWAL !

Walther Trowal GmbH & Co. KG
Rheinische Straße 35-37 | D-42781 Haan
Tel. +49(0)2129-571-0 | Fax +49(0)2129-571-225
info@walther-trowal.com | www.walther-trowal.com