

Metal Bellows Coupling I Series KGE

- for standardized interface connection DIN - EN - ISO 9409 - 1
- two-part connection flange / compact design / temperatures up to 300°C
- simple installation with lateral EASY-clamping hub at output side

technical data:

KGE size	nominal torque [Nm]	ISO 9409 interface	moment of inertia [10^{-3}kgm^2]	torsional stiffness [Nm/arcmin]			max. shaft misalignment [mm]			axial spring rate [N/mm]			lateral spring rate [N/mm]			tightening torque screws [Nm]			nmax [upm]			
				2W	4W	6W	2W	4W	6W	2W	4W	6W	2W	4W	6W	f	i	j				
40	40	A-31,5	0,2	6	3,4	6	0,3	0,5	0,8	0,1	0,15	0,25	100	55	50	2100	360	190	16	8	4	23000
140	140	A-50	1,2	32	20	13	0,3	0,6	1	0,1	0,2	0,25	210	110	80	7000	1200	400	40	14	8	18000
220	220	A-63	2	50	28	17	0,4	0,7	1	0,1	0,2	0,3	170	95	70	5000	1000	470	80	14	14	16000
350	350	A-80	4,2	93	52	47	0,4	0,8	1	0,1	0,2	0,3	170	90	95	7000	1300	500	135	35	14	13000
700	700	A-100	9,1	190	106	68	0,4	0,8	1	0,1	0,2	0,3	260	140	100	15000	2800	980	115	65	35	11000
1300	1300	A-125	34	400	225	170	0,4	0,7	1	0,1	0,2	0,3	310	160	120	4700	1900	920	300	65	35	8500
2000	2000	A-125	42	-	300	260	-	1	1	-	0,2	0,3	-	340	250	-	4700	1900	450	65	35	8500

Standard versions „6W“ with 6-corrugated metal bellows „4W“ with 4-corrugated metal bellows; „2W“ with 2 corrugated metal bellows

- permissible maximum torque = 2 x nominal torque
- maximum permissible operating speeds up to 20,000 rpm size

Material:

bellows: stainless steel

flange ring: heat treated steel - carbonized

clamping hub / flange hub: steel (St 52)

screws: ISO 4762/12.9

ISO 4017/10.9

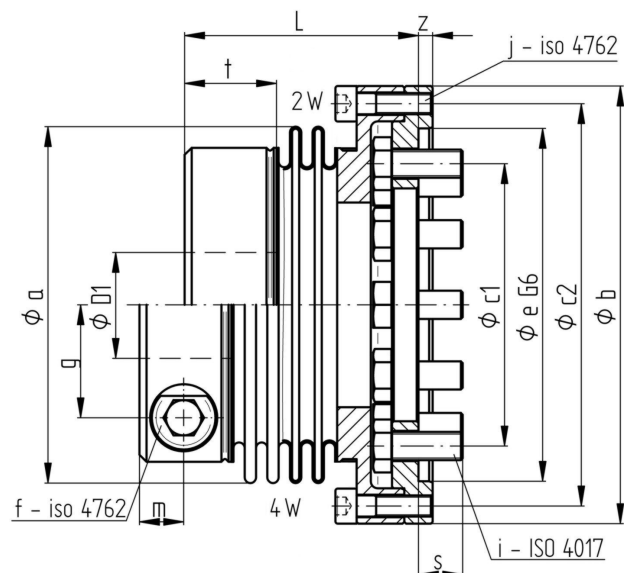

Dimensions [mm]: length dimensions according to DIN ISO 2768 cH

KGE	Ø a	Ø b	Ø c1	Ø c2	e	f-TA	g	i	j	L			m	s	t	z	mass	Ø D1	
										2W	4W	6W						~ [kg]	min
40	56	63,5	31,5	56,5	40	M6	18	8xM5	8xM4	46	57	67	7,5	7	16	2,5	0,6	12	32
140	71	88,5	50	80	63	M8	27	8xM6	8xM5	54	64	74	9	9,5	18,5	4	1,3	18	42
220	82	104	63	94	80	M10	27,5	12xM6	8xM6	59	71	84	11,5	10,5	22,5	4	1,7	20	42
350	101	124	80	114	100	M12	32	12xM8	12xM6	67	79	98	12,5	12,5	26	4	2,6	22	50
700	122	155	100	142	130	M12	40	12xM10	12xM8	73	89	103	11,5	15,5	24	4	4,3	42	64
1300	157	184	125	171	160	M16	54	12xM10	16xM8	90	107	124	17,5	18,5	35	4	7,5	45	90
2000	157	184	125	171	160	M20	58	12xM10	16xM8	-	117	133	22	18,5	45	4	9	60	90

order example:

KGE 350 / 4W

ØD1 = 38 G7

/

for ISO 9409 - interface A-80

KGE 140 / 2W

ØD1 = 28 G7

/

for ISO 9409 - interface A-50