

ENCLOSED WELD HEADS

OSK S/SW/GW, HANDLE AND CABLE ASSEMBLIES



OSK S GAS-COOLED WELD HEADS

Our new generation of THREE gas-cooled weld heads that have been technically optimised and redesigned and have a tube size range of OD 6 – 114.3 mm / 0.250" – 4.500".

Special design features and the material selection enable high thermal capacity, even without water cooling.

The heads are even narrower and have a quick clamp system for the collets.



Weld head:	Tube size range mm	inch	Weight
OSK 53 S	OD 6 – 53 mm	0.250" – 2.087"	2.1 kg
OSK 76 S	OD 6 – 76.2 mm	0.250" – 3.000"	2.6 kg
OSK 115 S	OD 9.53 – 114.3 mm	0.375" – 4.500"	3.4 kg

OSK S HANDLE AND CABLE ASSEMBLY, 8 m

Handle and cable assemblies consisting of a handle with control element (start/stop button and status display), weld head interface, motor / gearbox unit and 8 m hose package.

The OSK G and S handle and cable assemblies and weld heads are compatible with one another!

OSK SW WATER-COOLED WELD HEADS

Our new generation of three OSK SW weld heads – even narrower, technically optimised and redesigned. For very high thermal capacities, we also offer the gas-cooled S series weld heads in a water-cooled SW version (the structural width stays the same). The closed water cooling system covers the bottom collet housing area.

Weld head:	Tube size range mm	inch	Weight
OSK 53 SW	OD 6 – 53 mm	0.250" – 2.087"	2.1 kg
OSK 76 SW	OD 6 – 76.2 mm	0.250" – 3.000"	2.6 kg
OSK 115 SW	OD 9.53 – 114.3 mm	0.375" – 4.500"	3.4 kg

OSK 170 GW WATER-COOLED WELD HEAD

OSK 170 GW	OD 50 – 168.3 mm	1.969" – 6.626"	7.5 kg
-------------------	------------------	-----------------	--------

OSK SW HANDLE AND CABLE ASSEMBLY, 8 m

Handle and cable assemblies consisting of a handle with control element (start/stop button and status display), weld head interface, motor / gearbox unit and 8 m hose package.

The OSK GW and SW handle and cable assemblies and weld heads are compatible with one another!



Dimensions table for OSK SW and GW enclosed orbital weld heads

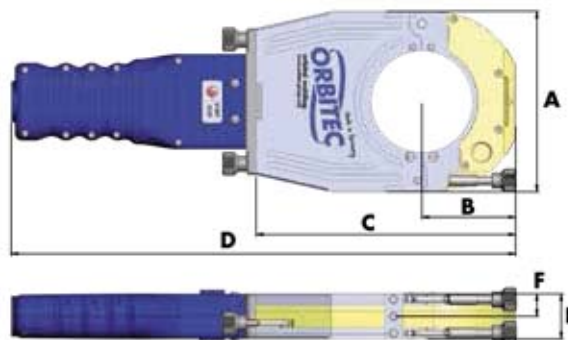

Weld head	A		B		C		D		E		F	
	mm	inch	mm	inch	mm	inch	mm	inch	mm	inch	mm	inch
OSK 53 S / SW	130	5.118	70	2.756	205	8.071	425	16.732	40	1.575	20	0.787
OSK 76 S / SW	160	6.299	83	3.268	230	9.055	450	17.717	40	1.575	20	0.787
OSK 115 S / SW	200	7.874	103	4.055	270	10.630	487.5	19.192	40	1.575	20	0.787
OSK 170 GW	270	10.630	132	5.197	343	13.504	563	22.165	44	1.732	22	0.866

Item number

1.0.2520
1.0.2620
1.1.2720
1.3.2057

Orbital welding systems

Welding tools

Welding accessories

Joint preparation

1.0.2520W
1.0.2620W
1.1.2720W

1.3.2899

1.3.2058

Purging accessories

Measuring devices

Service / general