

Profile

- Through hollow shaft \varnothing 14 mm
- Adaptation to various measurement paths owing to a wide range of gear ratios
- Compact, low-cost design
- Potentiometer or power output
- Easy mounting

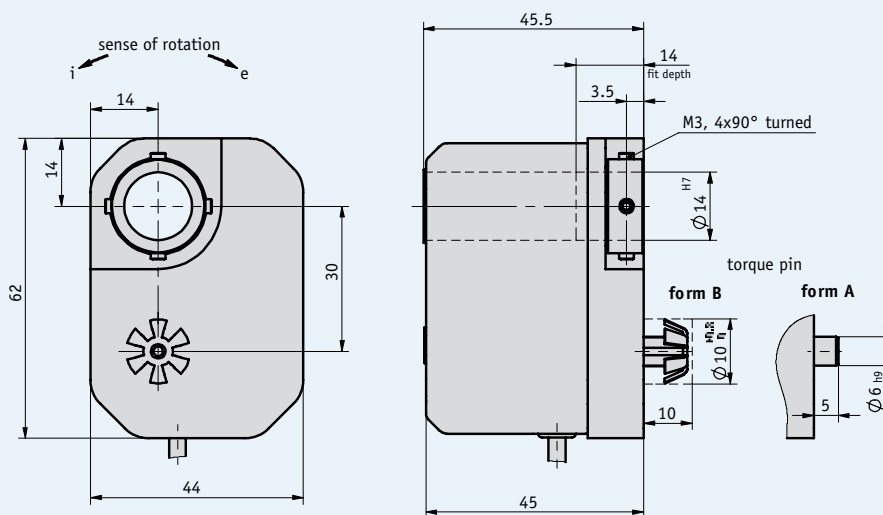

Mechanical data

Feature	Technical data	Additional information
Gear ratio	0.2 ... 128	
Speed	max. 500 rpm	depending on gear ratio
Operating temperature	0 ... +80 °C	
Condensation	inadmissible	
Service life of axial movement	1 x 10 ⁶ 2 x 10 ⁶	with P01, P02 with P03
Protection category	IP52	according to DIN VDE 0470
Shaft	browned steel, \varnothing 14 mm	
Housing	plastic	

Electrical data

Feature	Technical data	Additional information
Interference protection class	3	according to IEC 801

■ Analog outputs

Feature	Technical data	Operating voltage
Potentiometer output	0 ... 1 kΩ, 0 ... 5 kΩ, 0 ... 10 kΩ depending on the potentiometer type used	
Power output	4 ... 20 mA	24 V DC ±20 %, with load ≤ 500 Ω

■ Potentiometer type

Feature	01	02	03/0.1
Design	hybrid	wire	hybrid
Resistance	1 kΩ, 5 kΩ, 10 kΩ	1 kΩ, 5 kΩ, 10 kΩ	1 kΩ, 5 kΩ, 10 kΩ
Resistance tolerance	±5 %	±5 %	±5 %
Linearity tolerance	±0.25 %	±0.25 %	±0.1 %
Load rating	1 W at 70 °C	1 W at 70 °C	2 W at 70 °C
Range of rotation	340° ±5° (mechanically straight-through)	3600° ±10°	3600° ±10°
Standard terminal resistor (the higher value is always valid)	0.5 % or 1 Ω	0.5 % or 1 Ω	0.5 % or 1 Ω

Note: Characters highlighted in orange color are order features.

Pin assignment

■ Potentiometric outputs P01, P05, P10

Signal	Cable color
Po	brown
Pe	white
S	green

■ Transducer MWI

Signal	Cable color
I+	brown
I-	white

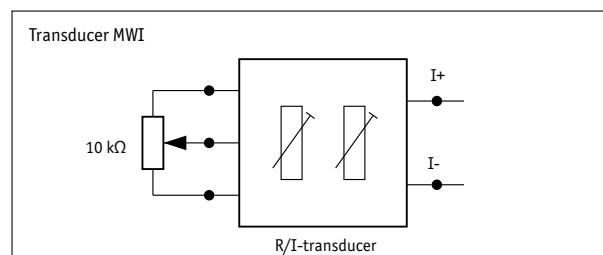
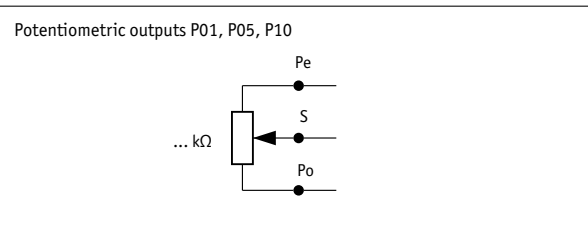

Order

■ **Ratio calculation** (order table, feature A)

$$\text{Formula: } i1 = \frac{n \times 360^\circ}{\alpha}$$

n = number of revolutions on the driving shaft
 α = potentiometer angle of rotation
 340° with 1-coil potentiometer
 3600° with 10-coil potentiometer
 i1 = order feature for gear ratio

If the calculated ratio "i1" is the same as a value in the ordering table for the "ratio" feature, but this is not available, select the next highest ratio.

■ **Order table**

Feature	Order data	Specifications	Additional information
Gear ratio	... A	0.2, 0.25, 0.333, 0.5, 1, 2, 3, 4, 5, 6, 7, 9, 10, 12, 15, 16, 20, 203.636, 24, 28, 30, 36, 36.571, 48, 55, 68, 80, 112, 128 others on request	
Torque support	A B	B form A, cylindric pin form B for tolerance compensation	
Potentiometer type	01 02 03 03/0,1	C 1 coil, hybrid 10 coils, wire 10 coils, hybrid 10 coils, hybrid, linear tolerance 0.1	
Resistance	P01 P05 P10	D resistance 1 kΩ resistance 5 kΩ resistance 10 kΩ	
Transducer	MWI OMW	E transducer 4 ... 20 mA without	only with P10 and potentiometer type 02 or 03
Sense of rotation	ODR e i	F without indication of sense of rotation counter-clockwise ascending values clockwise ascending values	with P01, P05 or P10 with MWI with MWI
Cable length	... G	0.2 ... 15 m in steps of 0.1 m	

■ **Order code**



Scope of delivery: GP02, User information



Accessories:

Electronic display MA50

Page 92

Additional information:

General information and areas of application

Page 64 cont.