

ProArc Magicut is a cost-effective cutting solution in its class. Supporting standard plasma and up to 4 oxyfuel torches, its compact design provide maximum working area with smallest floor space requirement.

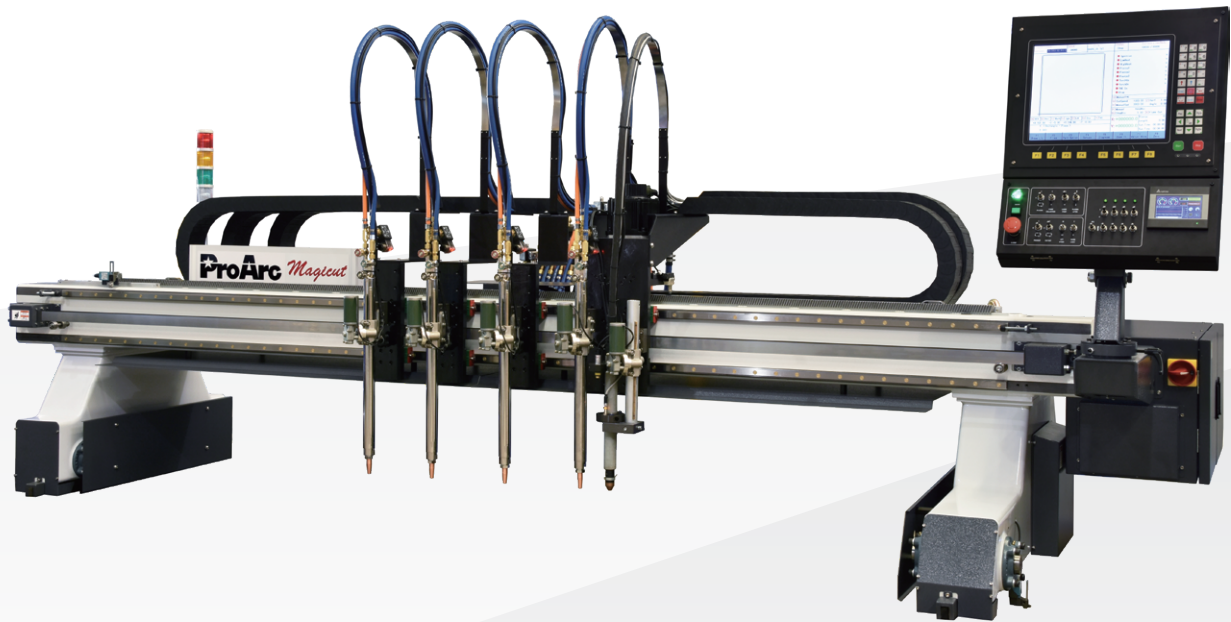

• Plasma torch

Optional accessories

- Plasma torch.
- Laser point positioning unit.
- Anti-collision device
- Heavy duty fume collection duct.
- Track base foundation.
- Dust collector.

MAGICUT

CNC Cutting Machine

High Productivity / Low Investment

Specification

Model ^{*1}	Unit	Magicut 20s / 20	Magicut 25s / 25	Magicut 30s / 30	Magicut 35s / 35	Magicut 40s / 40
Power input ^{*2}	~	AC 220, 50/60Hz, 3 Phase				
Drive method		Rack & Pinion				
Overall width (A)	mm	2,900	3,400	3,900	4,400	4,900
Overall height (B)	mm	1,800	1,800	1,800	1,800	1,800
Overall depth (C)	mm	1,250	1,250	1,250	1,250	1,250
Cutting width (D)	mm	1,600	2,100	2,600	3,100	3,600
Rail gauge ^{*3} (E)	mm	2,000	2,500	3,000	3,500	4,000
Parking space	mm	1,250				
Cutting speed	m/min	8/12				
Traveling speed	m/min	12/16				
Min. distance between 2 torches	mm	100				
Weight	kg	1,230	1,275	1,330	1,540	1,600

※ Specifications subject to change without notice

※1 Magicut 20s / 25s / 30s / 35s / 40s are single drive on longitudinal axis

※2 Other power input available

※3 Special large rail gauge available

Dimensions

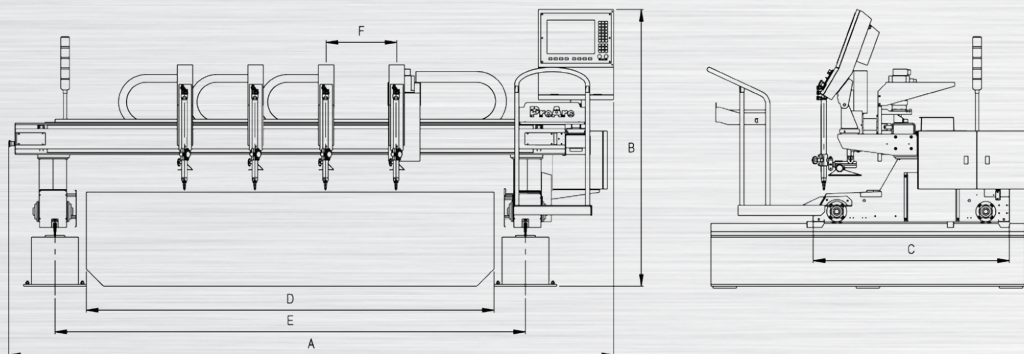

UNITED PROARC CORPORATION

No.3 Gungye 10th Road, Pingjen Industrial Park, Pingjen Dist., Taoyuan City 32459, Taiwan

Tel:886-3-4696600 Fax:886-3-4694499 E-mail:sales@proarc.com.tw

SD-4003HE