

# Torque Gauge – ATGE-G

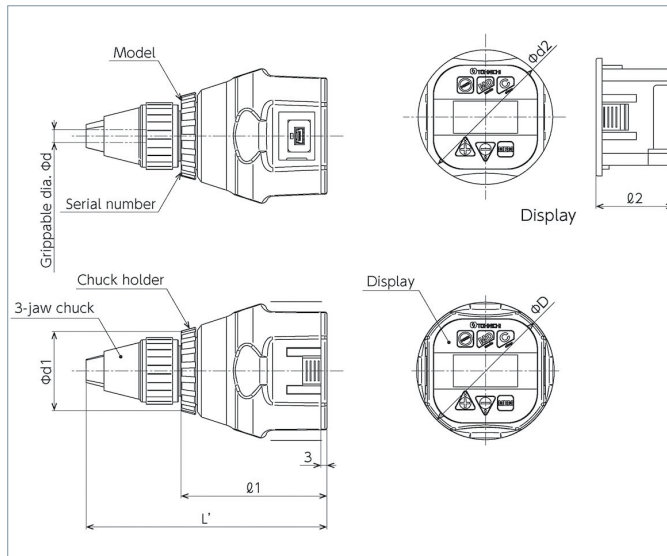

Img: ATGE1CN



- ▶ Accuracy  $\pm 2\% + 1$  digit.
- ▶ 7 segment LCD: Torque unit, Battery indicator, Direction, Counter 3 digits, Torque value 4 digits.
- ▶ 2 measurement modes: Peak, Track.
- ▶ 3-way configuration: Hand-held, Table top, or as a Torque meter with testing fixture.
- ▶ Aluminum cover and 3-jaw keyless steel chuck as standard.
- ▶ Physical stopper prevents accidental over-loading.
- ▶ 999 readings can be saved with computing function for max/min/mean.
- ▶ Coin-type lithium battery (CR2450) allows 10-hour continuous operation.
- ▶ USB cable can be used for data transfer to PC.

Delivery in firm storage box incl. traceable calibration certificate (ISO/JCSS), operating manual and Lithium coin cell CR-2450.

## Digital Torque Gauge with pull-out LC-Display

High precision handheld digital gauge with integrated LC display to measure small torque. Ideal for torque measurement like rotating torque, click torque of precision machinery, electronic devices, and various assembly components.

The digital display simply slides out of the housing and is attached with a curly cord. Use the optional testing stand to secure the gauge while testing or add fixture to secure your test piece. Combined with Measurement Stand (#808), it can be fixed to use as torque screwdriver checker, et al.

ATGE-G series devices are manufactured for the global market and offer a selection of SI, metric and American units of measurement. Equipped with SI calibration as standard, optionally available with calibration in english (ozf-in) or in metric (gf-cm) units.

### Optional Accessories

INFO

- Measurement Stand #808
- Testing Fixture #800 (clamp diam. 10-58 mm)
- USB Cable #384 (free Data Receiver Software available\*)
- AC Adaptor #BA-7 (requires cable #384)
- Battery-Pack #BP-C1 (for up to 50 hrs continuous use)
- Resin Chuck #322
- Calibration Adaptor #806
- Calibration Kit #ATGTCL24CN

## ATGE-G

Model	Item No.	Torque Range						Dimensions		Chuck	Weight
		cN-m		gf-cm		ozf-in		L'	øD		
		Min - Max	1 Digit	Min - Max	1 Digit	Min - Max	1 Digit	mm	mm	mm	kg
ATGE05CN-G	T251100	0.1 - 0.5	0.001	10 - 50	0.1	0.15 - 0.7	0.001	120	67	1 - 6.5	0.31
ATGE1CN-G	T251101	0.2 - 1	0.001	20 - 100	0.1	0.3 - 1.4	0.001	120	67	1 - 6.5	0.31
ATGE2CN-G	T251102	0.4 - 2	0.002	40 - 200	0.2	0.6 - 2.8	0.002	120	67	1 - 6.5	0.31
ATGE5CN-G	T251103	1 - 5	0.005	100 - 500	0.5	1.5 - 7	0.005	120	67	1 - 6.5	0.31
ATGE10CN-G	T251104	2 - 10	0.01	200 - 1000	1	3 - 14	0.01	120	67	1 - 6.5	0.31
ATGE20CN-G	T251105	4 - 20	0.02	400 - 2000	2	6 - 28	0.02	120	67	1 - 6.5	0.31

\* Data Receiver software is a data input tool for Excel® data management. It can be downloaded for free. Note: Excel® is a registered trademark of Microsoft Corporation.

