

BEHRINGER

HCS High-Performance Automatic Circular Cold Saws

HCS 70 | HCS 90 E | HCS 100 MF | HCS 130 MF | HCS 160 MF | HCS 180 MF

EISELE

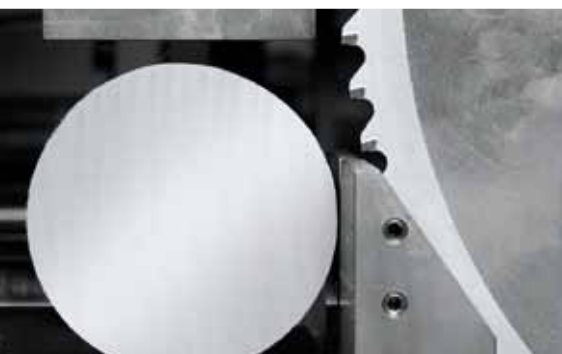

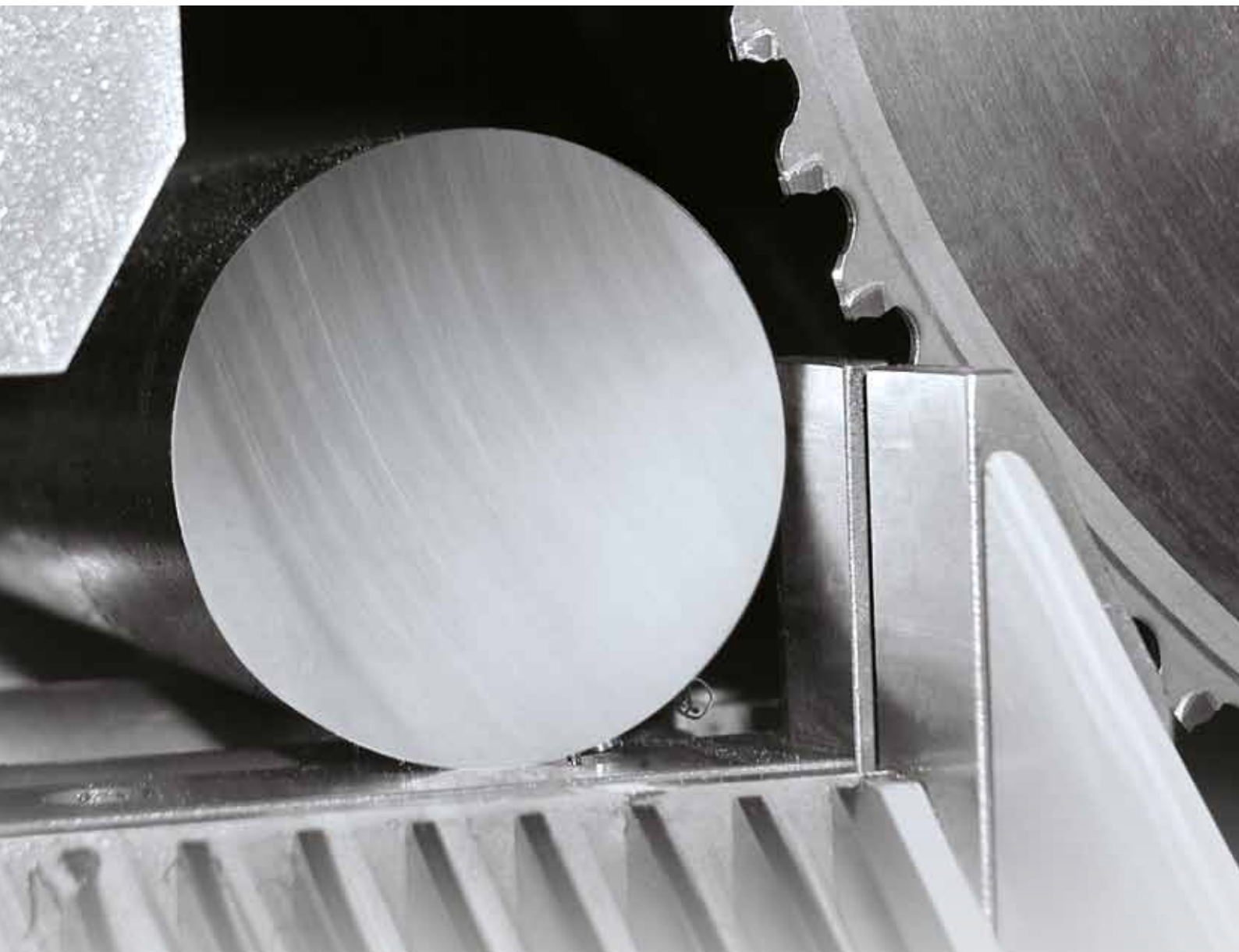

*Christian Behringer and
Thomas Großkopf are the managers
of BEHRINGER EISELE*

Sawing is our world, our passion and competence. Our innovative and high-performance sawing technology along with the strong EISELE brand makes us one of the leading suppliers of complete sawing systems on the market. Our top quality saws and sawing systems are the product of our vast expertise and our solid engineering skills. Our know-how is the result of experience and communication, something we are very proud of.

As a globally active family-owned business, communication with our customers is of utmost importance to us. Our aim is to gain 100 % of our customers' confidence and trust. In order to present reliable, market-oriented and precise custom-made solutions, we work with team-spirit: our design teams, our manufacturing teams, assembly, and after-sales teams work hand-in-hand to provide our customers with everything they need from a single source.

Everything made and designed by BEHRINGER.
This is what the BEHRINGER name.

Perfection from tradition

It is the passion for the sawing process that has been driving us as industry leaders in band saw and circular saw technology.



Innovative Sawing technology – A worthwhile investment

Whether shop floor model or high-end industrial saws – our aim is to always be „one step ahead“ in terms of sawing performance and accuracy.

We work closely together with saw blade manufacturers, we carry out tests with materials from our customers, and we are always looking for new challenges in the field of cutting steel, aluminum and special alloys. Through our constantly improving saw technology and innovation, we are able to support our customers and to give them a clear advantage in times of fierce competition. Such an investment is worthwhile from the very first day.

We are BEHRINGER – With passion

It is the ambition of everyone on our team, which brings us forward. Our highly qualified engineers and technicians are working constantly to improve and further enhance our products. They conceive new products and features,

refine, develop, and manufacture our high-performance saws in a committed and target-oriented manner. We are always striving for perfection – always with enthusiasm for new challenges.

Made by BEHRINGER – Made in Germany

„From red iron to the finished product“ – the extensive production depth, high-end machining centers, state-of-the-art manufacturing methods and the integrated quality assurance system ensure the high quality standard of our products at every stage.

Our own latest-state-of-the-art foundry and our long experience in the field of ductile and cast iron contribute to the premium quality of our cast components. This is how we achieve a high degree of toughness, a solid construction for maximum performance, high cutting accuracy and long service life of the tools and of every original BEHRINGER and BEHRINGER EISELE sawing machine.



Customer-oriented sawing concepts

We know exactly what our customers need in terms of sawing. We understand their needs by always keeping in touch.

EISELE –

The strong brand of BEHRINGER

BEHRINGER EISELE is the absolute specialist when it comes to cutting steel or non-ferrous metals. The integration of the well-established circular sawing manufacturer EISELE into the BEHRINGER Group in 2001 completed our product range, making us one of the few full-range suppliers on the market. BEHRINGER EISELE re-defines the circular sawing process, in regard to „Cutting cycles – a matter of seconds“, for highest quality standards and an extraordinarily long service life. Something our customers know and care about.

Individual solutions are our strength

BEHRINGER EISELE is your competent partner, especially for custom-made sawing systems with material in-feed and out-feed equipment. Our technicians and engineers are listening to our customer's needs and provide tailor-made solutions. We also have the resources to take over the com-

plete project management if the customer wishes. Our modular concepts of saw and periphery products enable us to find reliable solutions, providing process efficiency over the whole production cycle.

We are local as well as global

We are in places where our customers are – nationwide and international. With our locations in Germany, France, USA and China as well as with over 40 agencies worldwide, we are setting the standard in terms of implementing customer-focused service and communication. We know the markets, the industry, and its challenges.

A well-developed network of service technicians and service partners ensures prompt after-sales support on a manufacturer's quality level. Our well-equipped spare parts storage and in-house manufacturing assure a fast and – even more importantly – reliable spare parts supply, even for saws, which have provided more than 30 years of service.



The HCS Standards

The Basic Models

- HCS 70
- HCS 90 E

The HCS Multi-Fluid series with an innovative cooling concept

- HCS 100 MF
- HCS 130 MF
- HCS 160 MF
- HCS 180 MF



The HCS Series: The Number One in High Performance and Precision

Work with a BEHRINGER EISELE HCS automatic cold saw and you will experience a new definition of Performance, Precision and Efficiency!

Features of the HCS series

- **Drive unit with 8-26 kW**
For optimum sawing performance
- **Feed axis with servo motor**
For accuracy and precision
- **Fully enclosed machine**
Meets the latest safety requirements
- **Cooling and lubrication by a Micro-Spraying system**
For minimal quantity lubrication applications

The steel-cutting high-performance automatic circular cold saws of the HCS series offer flexible solutions for the most varied sawing requirements – from the very basic model up to the complex system with Multi-Fluid package. No matter which type – each HCS saw stands for top cutting performance and premium quality.

Each model pays off quickly in multi-shift operation and increases profitability many times over when it comes to cutting solid material or thick-walled profiles. The basis of this outstanding performance is the unique construction with perfectly tuned components. They are all easily accessible to reduce downtimes.

The unique BEHRINGER EISELE

The extraordinarily sturdy and robust base construction is the basis of each HCS. It provides excellent dampening of vibrations and ensures optimum power transmission – typical for BEHRINGER EISELE. This also allows for a long service life, improved cutting surface, and an accurate and square cut.

Inclined is good

The inclined sawing console ensures optimum evacuation of the flying chips - this is one of many BEHRINGER EISELE inventions, globally revolutionizing circular cold saw technology.

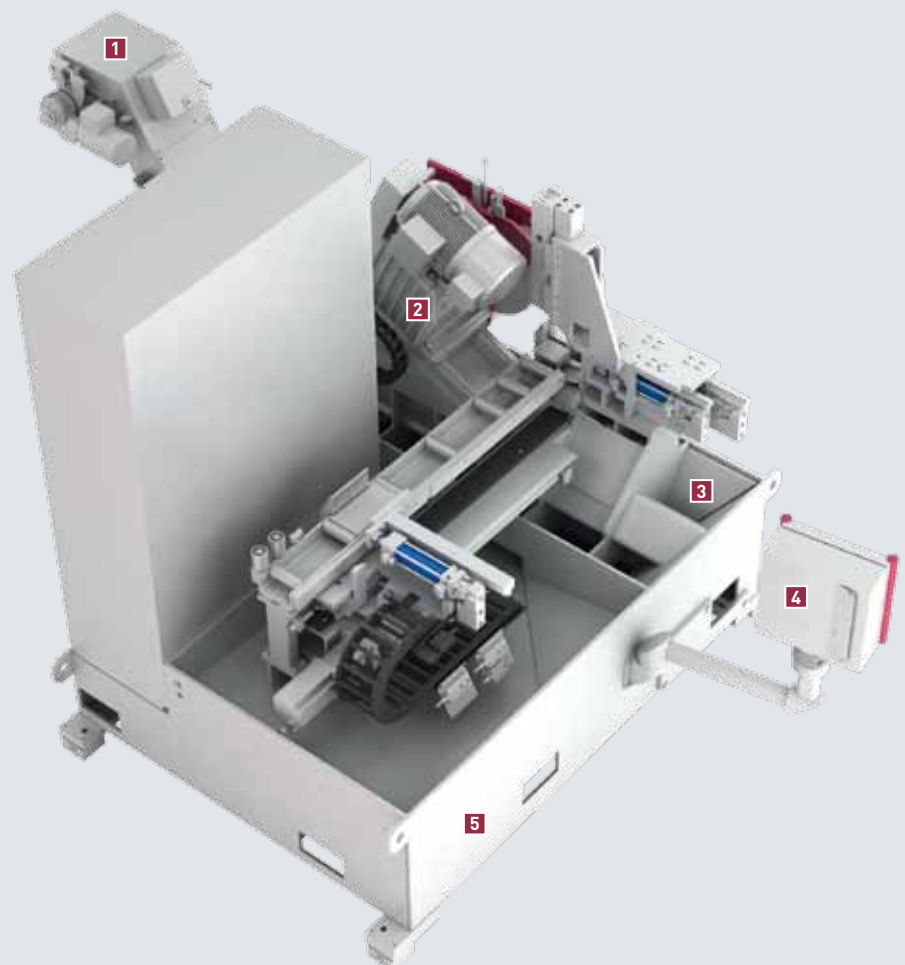

- 1 Chip conveyor
- 2 Saw console
- 3 Funnel-shaped machine base
- 4 Swiveling control panel
- 5 Robust and sturdy machine base



Funnel-shaped machine stand

Each model has a funnel-shaped machine stand, located under the saw unit. It provides for optimum evacuation of the flying chips into the chip conveyor and a smooth and speedy disposal of chips and coolant fluid. This design allows for easy cleaning.



Chip conveyor with coolant tank

The chip conveyor is a standard feature of the HCS. It swiftly removes the sawing chips. This is essential for a high-performance sawing process. The chip conveyor is located beneath the machine and can be removed for cleaning.

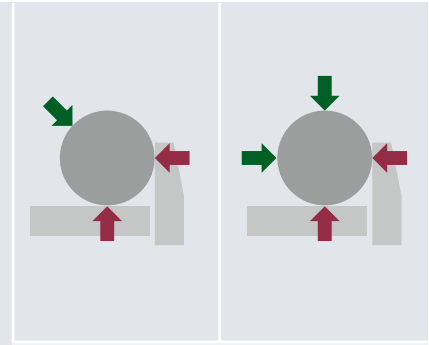

Material clamping device

The robust, hydraulically operated multiple-point clamping device allows for a quiet and smooth cutting process.



Servo-driven feeding gripper

The servo-driven feeding gripper swiftly positions the material precisely and in a matter of seconds. Its advantages are: accurate cutting length and short cycle times with tight tolerances.



Simple and intuitive operation of the control unit

Everything under control! The control unit is self-explanatory and easy to operate; operating mistakes are avoided and it allows for quick navigation within the program menu.



Robust, low-vibration gear unit

The heart of the saw unit is the worm gear unit, produced in-house. It is heavy-duty and provides for a smooth, low-vibration running of the saw, which, of course, has a positive impact on the quality of the cutting surface and the blade life.

HCS 70 and HCS 90 E: The access to the „Upper Class“

The entry in HCS technology: large-scale production with a maximum of output and quality. An investment that pays off quickly.

We know how a high-performance automatic circular saw has to be designed to give you an easy start in high-performance sawing, profitable for you right from the start.

High-quality components and technical finesse make the HCS 70 and HCS 90 E a real BEHRINGER EISELE saw. Being reliably working saws, focused on the

basics, they are the leaders in terms of performance in their class. A drive power of 8 kW and saw blade sizes of up to 315 mm provide for a large application range.

HCS 70 – A basic model, which has got the drive...

The HCS 70 combines well-tested features and innovation. With the standard version having a blade speed range as large as 25 to 215 min⁻¹, an almost boundless field of applications can be covered.



HCS 90 E – A complete system package

BEHRINGER EISELE offers a package to enter HCS high-performance sawing technology, which includes the steel-cutting high-performance automatic circular cold saw, a loading magazine and the chip conveyor.

And what is remarkable: This system concept covers a large range of all

industrial requirements, providing the highest quality at an unbeatable price-performance ratio.

The HCS 90 E is the ideal cold saw for solid material and tubes up to a diameter of 90 mm. Loading of rectangular profiles up to 65 mm with the magazine is an available option.

Features of the HCS 90E

The HCS 90 E includes:

- The HCS 90 Steel-cutting high-performance automatic circular cold saw
- The loading magazine SM 90
- The chip conveyor

The HCS 90E concept is a rather compact, self-contained unit. If other components or devices are to be linked, we recommend a custom-made design, which exactly suits your requirements.



Technical Data

Model		HCS 70	HCS 90 E
Saw blade diameter	[mm]	250 / 285 / 315	250 / 285 / 315
Cutting range 90° round	[mm]	10 - 75	12 - 90
Cutting range 90° square	[mm]	10 x 10 - 60 x 60	12 x 12 - 65 x 65
Standard blade speed	[1/min]	25 - 215	25 - 215
Drive power – frequency-controlled	[kW]	8	8
Min. rest piece length	[mm]	70	60
Feed length single stroke	[mm]	1000	1000
Max. material feed rate	[mm/sec]	1250	1000
Saw feed rate	[mm/sec]	0,5 - 40	0,5 - 40
Dimensions without magazine L x W x H	[mm]	2020 x 1736 x 2064	2480 x 1850 x 2000
Weight without magazine (approx.)	[kg]	2800	3200

HCS Multi-Fluid: Limits are newly defined

It is unique! The Multi-Fluid cooling concept multiplies the already high cutting performance of the HCS series many times over.

Shorter cycle times, higher output – the Multi-Fluid concept of the HCS MF-series opens new horizons of efficiency thanks to its pinpoint cooling during the cutting process. The Multi-Fluid system is excellent for high-alloy stainless steels and tool steels, nickel-based alloys like Inconel and Hastelloy as well as titanium alloys.

The results: effective cooling allows for high feed rates and shorter cutting cycles, while also increasing tool life considerably. Combined with the large saw blade diameter range (up to 520 mm), the HCS-MF automatic circular cold saws are unbeatable in their flexibility and profitability.

Depending on the requirements, the following cooling/lubrication components can be combined in a most effective way:

- Coolant nozzles for wet processing
- Micro-spraying device for minimum quantity lubrication
- Cooling vortex tube for dry processing



Modular use of saw blades

Here is the BEHRINGER EISELE philosophy:

Choose a minimum saw blade diameter for cutting diameters as large as possible

The logic behind this:

Small saw blades are less expensive, plus they are thinner, and therefore the loss of material during the cutting process is considerably reduced.

BEHRINGER EISELE's solution of modular use of saw blades makes the most of your investment.

Two or three saw blade diameters are sufficient for adjusting each HCS saw to the respective material diameter. This allows for maximum flexibility and profitability.

Another advantage:

The saw blade change takes only 3 minutes.

Blade vibration absorber (BVA)

The perfect interaction between the largely-dimensioned carbide metal guides and an effective brush-system, which pro-actively removes chips, ensures not only a maximum service life but also an optimized cutting surface and a precise and swift cutting operation. It can be easily adjusted to different blade thicknesses.

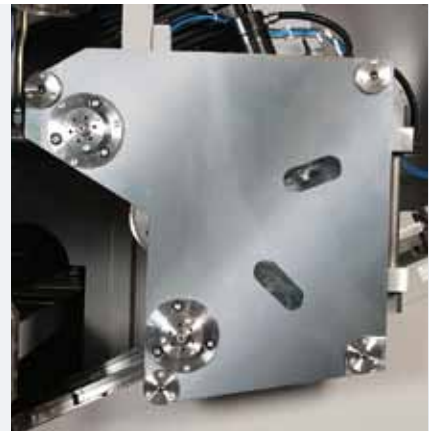

Multi-Fluid cooling system

Depending on the application or on the material characteristics, the following three cooling/lubrication components can be combined with each other in the most effective way:

- Coolant jet nozzles for wet processing
- Micro-spraying device for minimum quantity lubrication
- Cooling vortex tube for dry processing



Chip conveyor

The new chip conveyor houses the coolant tank and coolant pump saving space. It ensures a rapid removal of the sawing chips and is easy to clean and maintain.



Technical Data

Model		HCS 100 MF	HCS 130 MF	HCS 160 MF	HCS 180 MF
Saw blade diameter	[mm]	285 / 315 / 360	315 / 360 / 420	360 / 420 / 460 / 480	460 / 520
BVA – Blade Vibration Absorber		optional	optional	standard	standard
Cutting range 90° round	[mm]	12 - 105	20 - 135	20 - 160	40 - 180
Cutting range 90° square	[mm]	12 x 12 - 90 x 90	20 x 20 - 110 x 110	20 x 20 - 140 x 140	40 x 40 - 150 x 150
Standard blade speed	[1/min]	20 - 250	20 - 250	20 - 250	20 - 200
Drive power – frequency-controlled	[kW]	15	15	15	26
Min. rest piece length	[mm]	70	70	70	80
Feed length single stroke	[mm]	1000	1000	1000	1000
Max. material feed rate	[mm/sec]	1000	1000	1000	800
Saw feed rate	[mm/sec]	0,5 - 40	0,5 - 40	0,5 - 40	0,5 - 40
Dimensions without magazine L x W x H	[mm]	2660 x 2650 x 2450	2660 x 2650 x 2450	2660 x 2650 x 2450	2660 x 2650 x 2450
Weight without magazine (approx.)	[kg]	5500	5500	5500	6000

Customer-specific sawing systems: Loading magazines

The demand for even shorter cycle times puts high demands on the material handling process. BEHRINGER EISELE provides the solutions – in a systematic way.

We understand: the speed of the sawing process on a HCS depends on the material feed capacity. Therefore we optimize the material handling so that our customers can benefit 100 % from the performance of their HCS.

Our approach is: material is reloaded during the main operation time (cutting time). To minimize set-up times,

the next piece of material is loaded during the sawing process and automatically fed into the machine.

To load the material into machine, various types of loading magazines are available.



Bundle loading magazine BM

- Large loading capacity
- Simple handling
- Automatic separation of bar bundles
- Suitable for round material



The Universal bar loading magazine USM

- Automatic loading of round material
- Loading of rectangular profiles is possible as an option
- Robust construction, virtually maintenance-free
- Quick and simple loading process



Bar loading magazine SM

- Automatic loading of round material
- Robust design, virtually maintenance-free
- Quick and simple loading process



Flat loading magazine FM

- Handling of almost every profile shape
- Flexible loading system for various materials
- Handling of rest pieces is possible from the infeed side
- Flat loading magazine with active back-storing feature (optional)

Constant weight feature – 100 % good parts

This feature is particularly useful for the forging industry. An automatic query of the material diameter ensures a constant weight of the pieces cut.

Before the cut, the work piece is measured and any variations in diameter are compensated by adjusting the cutting length accordingly.

Ask our engineers for complete solutions for your individual requirements. It pays!

Customer-specific sawing systems: Disposal devices

If you talk about the sawing process, you must also think about the disposal process. Whether merely evacuating the cut pieces or feeding them to subsequent processing stations – We can handle your cut pieces and guide them to wherever you like.

If you need space-saving and reliable solutions, just contact us. We are your competent partner and we provide comprehensive solutions for disposal and sorting:

Inclined roller conveyors, disposal belts and hinged slat chain conveyors with sorting device are at your disposal.

Integration into the whole process

Your HCS system can be linked with the following subsequent processing steps:

- Chamfering
- Measuring
- Drilling
- Packaging
- Weighing

We will consult you competently.

Outfeed portal

- Reliable removal of the cut pieces from the cutting area
- Disposal and transport of cut pieces to defined positions with servo drive





Switch (Standard feature)

- Used for short pieces
- The pieces can be disposed into 2 containers (e.g. separate containers for trimcut and short rest pieces)

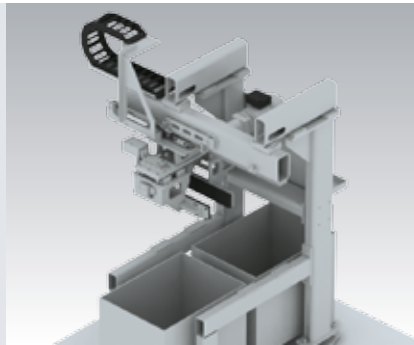

Disposal grippers

- Hydraulically-powered or with servo motor
- Removes the pieces from the cutting area in a smooth and reliable way
- Transfer to roller conveyor or belt conveyor



Belt conveyor with pushing devices

- Used in connection with disposal grippers
- Safe transport of material – including short pieces
- The pushing devices push the pieces in various boxes provided for disposal



Inclined roller conveyor with collection boxes

- Linked directly to the outfeed portal
- Pieces can be taken out from both sides



Powered roller conveyor with pushing devices

- Smooth evacuation and transport of cut pieces (medium and long)
- The pieces are pushed into boxes or pillars from where they can be removed easily



Robot cells with automated pallet station

- Flexible system for organizing cut pieces

BEHRINGER



The BEHRINGER EISELE Product Range

- Vertical circular cold saws VMS
- Up stroking miter circular cold saws PSU
- Fully-automatic Aluminum-cutting circular cold saw VA-L
- Fully-automatic steel-cutting circular cold saw HCS
- Loading magazines, disposal devices and material handling systems
- Complete sawing systems – overall concepts
- Integration into existing processes



Behringer Eisele GmbH

Austrasse 29

D-73235 Weilheim / Teck

Phone +49 (0) 70 23 / 9 57 57 - 0

Telefax +49 (0) 70 23 / 9 57 57 - 80

info@eisele.behringer.net

www.eisele.behringer.net