

Safety - PLd

Vibration sensor / -monitor, acceleration sensor

Model NVA / S3



NVA115

Certified
EN ISO 13849: PLd

- **Contactless, wear-free sensor system in MEMS technology**
- **Number of measurement axes: 2**
- **Frequency range: 0.1 ... 60 Hz (opt. 0.05 Hz)**
- **Measuring range: ± 2 g**
- **Interfaces:**
 - ◆ CANopen safety PLd
 - ◆ 2 switching contacts PLd
- **Special features:**
 - ◆ Type of filter selectable
 - ◆ 'Safety Shut off' SSO due to heavy strokes
 - ◆ "Switch off phasing" adjustable
 - ◆ Various signal settings (RMS etc.)
- **On request**
 - ◆ 'FFT' - fourier frequency detection
 - ◆ 2 analogue outputs

Design

The sensor system is intended as a component for use e.g. in wind power plants to measure and evaluate vibrations in the mast head. Registration of dynamic accelerations by means of MEMS sensors (Micro-Electro-Mechanical System) with subsequent digitisation by a controller.

The device consists of an acceleration sensor, a controller unit and three types of output interface. The main feature is two safety switching contacts (potential-free), which can be used e.g. in the safety chain to undertake safety shut-off in the event of excessively high acceleration values.

Data output is carried out via the CANopen interface.

The standard or the safety profile can be selected.

There are additionally two analogue outputs 4 ... 20 mA, which can be optionally assigned to two of the three measurement axes.

Thanks to its high resistance to vibration and shock, the sensor is suitable for use in areas with rough environmental conditions.

Electrical connection is carried out using two or three connectors.

Function

MEMS sensors are integrated circuits which are manufactured in silicon bulk micromechanics technology. They have a long service life and are very robust.

After determining the steady component and scaling, the measured values supplied by the acceleration sensor are

made available to the six filter units. The steady component arises as a result of installation which is not precisely horizontal, with the result that part of the earth's gravitational field would also be measured. The offset which occurs in the measured vibration value curve (zero point shift) due to the steady component is determined by means of calculation (distribution of the positive and negative measured values around the zero point) and is subtracted. The pure alternating component is output within a matter of 20 seconds. This calculation takes place continually. This function can be shut off in the factory.

The filter units can be individually programmed in the filter characteristics for frequency selection in the factory (low pass or band pass). They can be assigned to axes x, y or the resulting ones. Certain types of filter (kind, order, frequency limits) can be defined by the customer and can then be selected via CANopen.

The signals which are then available can be used for:

- ◆ activation of the safety switching outputs, time delay on demand (g limit values and assignment)
- ◆ output on CANopen / CANopen safety
- ◆ selection of momentary or RMS output or peak or integral output
- ◆ output on analogue outputs (not certified) (amplification factor and assignment)

The majority of parameters can be set using the CANopen interface.

Description

See document NVA13660 for detailed information

General information

The vibration sensor measures on two axes in a frequency spectrum from 0.1 to 60 Hz (Option: 0.05 to 60 Hz). This spectrum can be subdivided into a maximum of 6 frequency ranges. The frequency ranges are set in the factory. All acceleration values acting within the relevant frequency window are registered and are output firstly as an analogue value (4 ... 20 mA, max. two outputs possible) and secondly as a digital value via CANopen or CANopen safety. The acceleration values which are present are additionally compared with limit values (maximum values). If these limit values are exceeded, relevant switching contacts switch (a maximum of two is possible). In normal operating status, the contacts are closed. There is a warning stage and an alarm stage. The limit values for these stages can be set in the factory or by the customer. After 30 seconds, the warning status is reset to normal operating status if the measured acceleration level are not exceeding the warning limit any more. The alarm status can only be deleted through a reset.

The measuring axis is x, y or z or the vector sum $\sqrt{(x^2+y^2)}$ built from x and y.

The acceleration value (instantaneous value) can be used directly or a mean value of the acceleration which occurs (RMS) may be used as the output value and the further processing value for the relay circuit. The time over which averaging is carried out can be set.

Filter characteristics

Digital pre-filtering is initially carried out in the MEMS sensor to extensively suppress higher-frequency interference vibrations ($> \approx 100$ Hz), as they reveal comparatively high amplitudes due to the higher frequencies (1st-order FIR filter).

The individual frequency bands are then realised in the downstream controller via digital 8th to 11th-order Chebichev filters (11th order in the lower frequency range, 8th order in the upper frequency range). Other types of filter can be prepared by TWK on customers demand (e.g. Butterworth of 2nd order). These filters can be activated by CANopen object 322x/08.

The 6 filter units are of the same design; their characteristics can be set in the factory as desired by the customer. In the standard version, these filters (low-pass, band-pass and high-pass) are implemented as Chebichev filters. Chebichev filters are continuous frequency filters which are designed for the sharpest possible kinking of the frequency response at the limit frequency f_g . To achieve this, amplification in the pass range or in the stop range is not monotonous but possesses a waviness which has to be defined. The higher the permissible waviness, the sharper the drop within an order. A distinction is made between type I and type II Chebichev filters. In the pass range, type I Chebichev filters possess an oscillating frequency response curve. Type II Chebichev filters have this frequency response waviness in the stop range and are also referred to as inverse Chebichev filters in the specialist literature. The case here involves type II.

The maximum upper frequency limit of the vibrations to be measured is 60 Hz.

The steady component - generally caused by axis inclination on inclined installation - is calculated out by means of averaging which is performed prior to filtering. As a result of this, the lower limit frequency - irrespective of filter - is around 0.1 Hz (optionally 0.05 Hz). Steady component suppression can be shut off in the factory.

Figures 1 and 2 show examples of a possible frequency curve. The filter's output values are signed.

The output of each filter 1 - 6 is further processed for the analogue outputs (filters 1 + 2 only), for output via CANopen and for the limit value relays which respond to the exceeding of acceleration limit values.

The filters' relevant output signal can be set via the CANopen interface as follows:

- Output of the momentary value of the measured acceleration
- Output of a mean value over time for the measured acceleration (RMS averaging time adjustable via CAN)
- Output of a summarized value if the measured acceleration exceeds a customer defined limit

Switching outputs

The switching outputs react to the amount of the filter's output value (amount = folding up of the negative half-waves of the measured vibration curve).

The warning output is activated after exceeding the corresponding limit, i.e. the relay contact opens. The relevant relay drops off. It is reset when the limit is no longer reached for 30 s. Otherwise the time is extended.

The alarm output is activated after exceeding the corresponding limit, i.e. the relay contact opens. The relay drops off and remains constantly triggered. It can only be deleted by resetting the system.

The reference value is the amount of the currently measured vibration's momentary value. If a positive deviation event occurs 1 x, the corresponding relay is triggered. During normal operation, the relays are picked up. They drop off in the event of triggering or when the NVA is voltage-free.

Special features like an integral function, an FFT analysis (not certified) and a self-test function are available (see NVA13660). Shut-off in a specific vibration phase which can be specified by the customer can also be set - important for the NVA as a mast vibration monitor.

Every NVA provides that the switching contacts switch immediately when the wind power plant is exposed to a heavy stroke or shock. The according limit value is parameterizable. This provides shock detection and a "Safety shut off" in cases of these heavy shock exposure: SSO.

Examples for filter output

Amplitude vs f

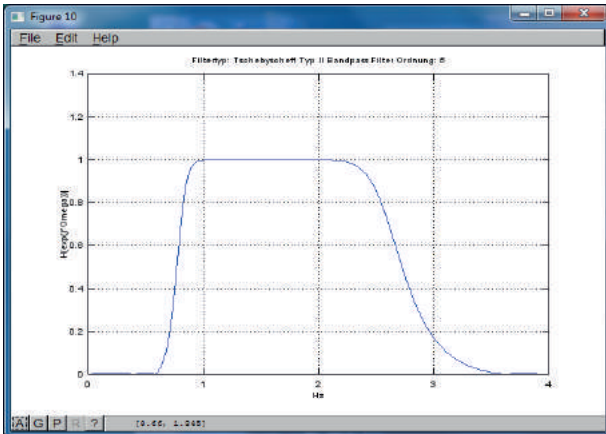

Fig. 1: Example band pass filter $f_{gu} = 0.8\text{Hz}$, $f_{go} = 2.5\text{ Hz}$

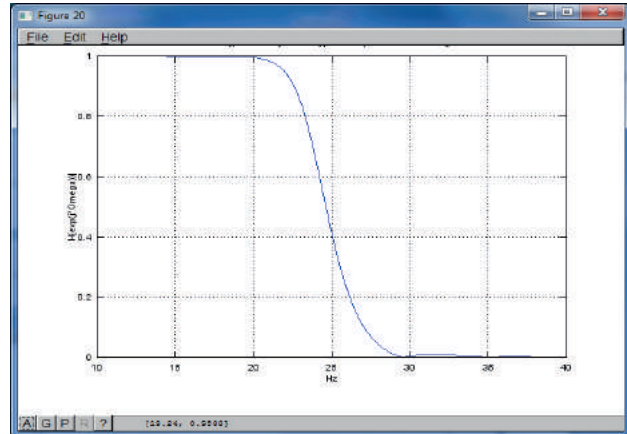
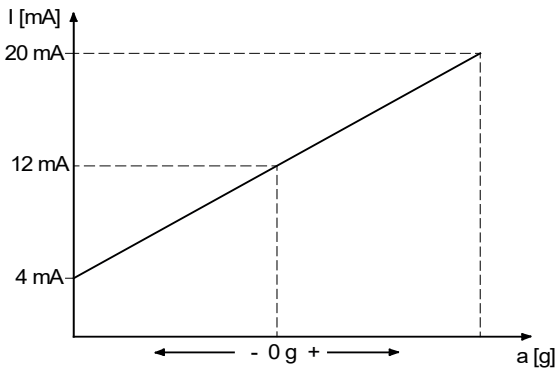

Fig. 2: Example of a low pass filter $f_{go} = 23\text{ Hz}$

Diagram for analogue output $I_0(a)$

not certified



Output: signed

- x, momentary value
- y, momentary value

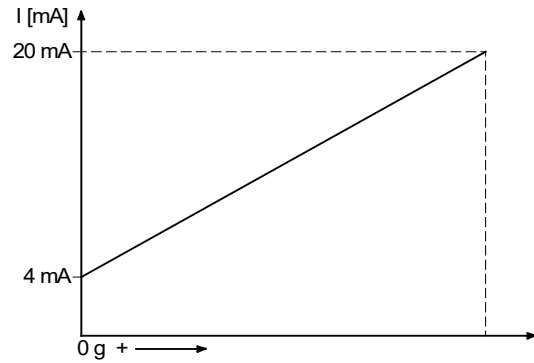

Output: absolute value

- x or y, RMS value
- x or y, Peak value
- $S = \sqrt{(x^2 + y^2)}$, RMS value
- $S = \sqrt{(x^2 + y^2)}$, momentary value
- Integral 1 or 2

Block Diagram

CAN-Bus

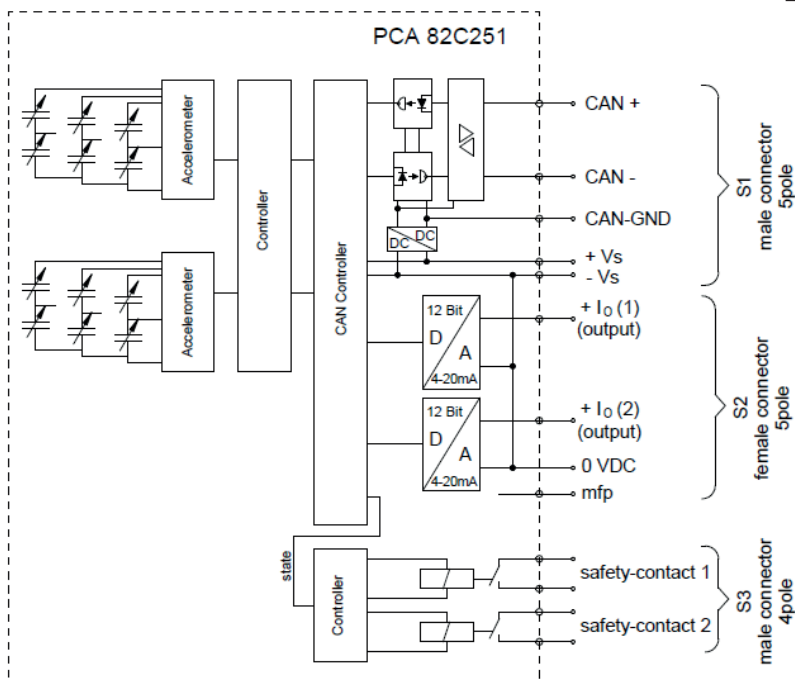

Following version is shown:
CANopen + Analogue + Switches

Frequency detection by Fourier transformation FFT

NVA version which provides the output of the spectrum of measured frequencies via CANopen. This spectrum is get by Fourier transformation (FFT) of the momentary value of the acceleration measurement versus time.

This functionality can be used for blade or tower frequency detection.

See two simple examples for such a transformation as well as a real spectrum are shown in the following diagrams.

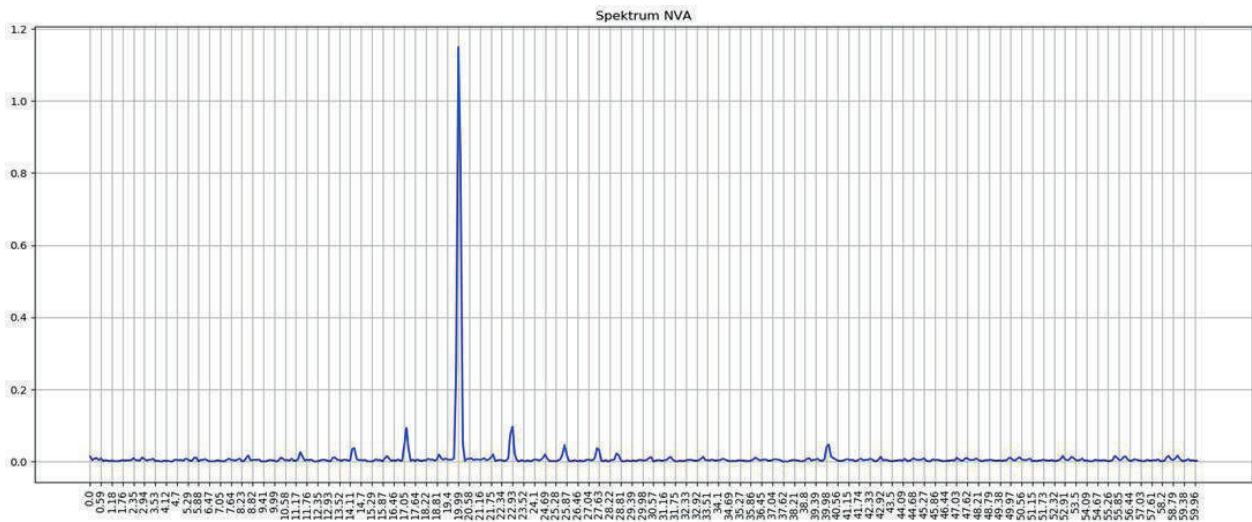
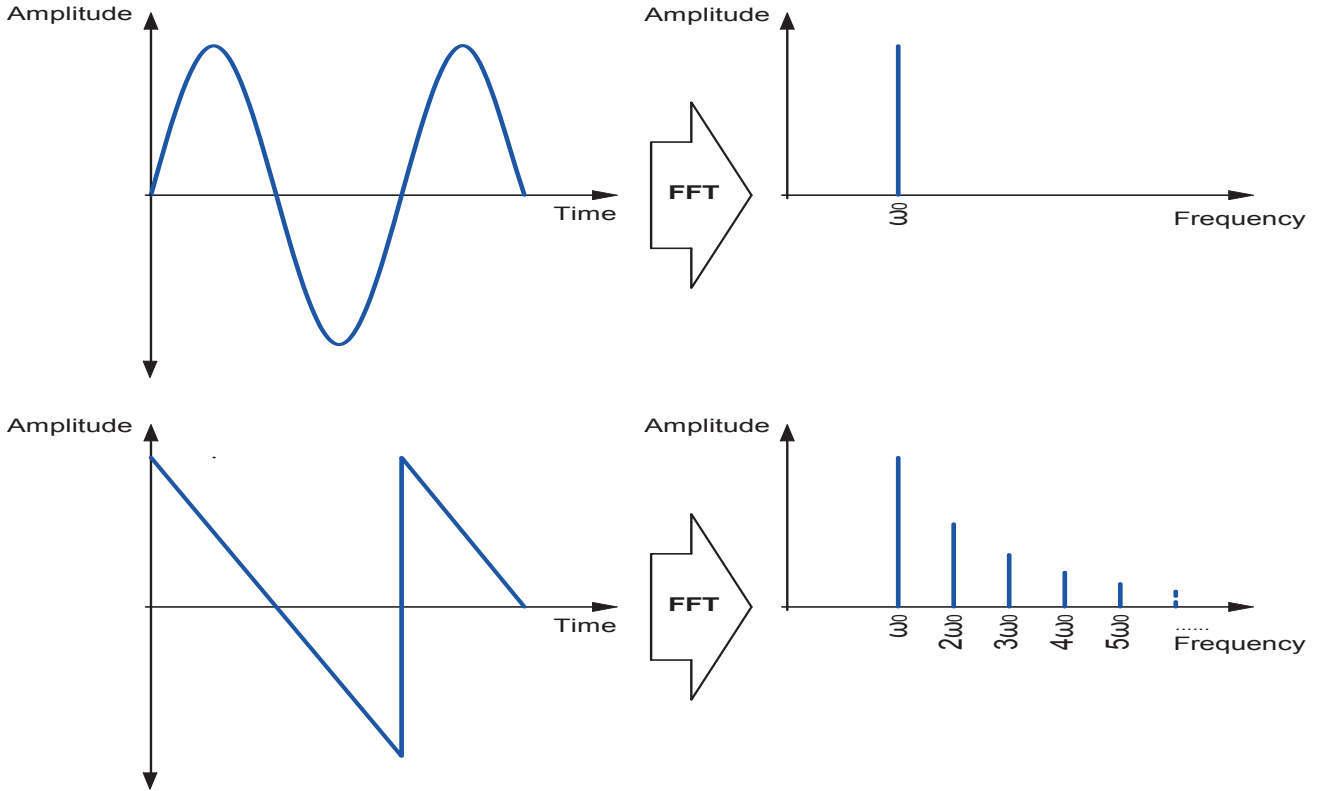

The spectrum of FFT analysis is transmitted to the turbine controller CANopen object 340x, sub C. The controller can evaluate this information. In addition the values of acceleration amplitudes (g_{max} vs f) due to FFT analysis can be used by NVA/S3 for switching off procedures via the internal safety switching contacts when limits are exceeded (These switching off procedures are only on request).

The highest five acceleration maxima $a(f)$ can be get from FFT analysis. They can be read out via object 340x, sub E separately.

Instead of the five highest accelerations $a(f)$ the belonging swinging amplitudes $s(f)$ can be calculated via formula $s = a / (2 \pi f)^2$ and read out via 340x, sub E.

Programmable features

Parameters programmable via CANopen interface

- Measuring axis: x, y or $\sqrt{(x^2+y^2)}$ separately for each filter (means output) 1 - 6
- Filtertype which is prepared by TWK due to customers requirements for each output 1 - 6
- Signal type at filter output 1 - 6: momentary value, RMS mean value, peak value, integration value
- Averaging time for signal type 'RMS', degressive time for peak, integration time
- Amplification for analogue outputs 4 ... 20 mA (Analogue outputs are assigned to filter 1 and 2) *
- Acceleration limit values (limit) for relay warning function
- Acceleration limit values (limit) for relay alarm function
- Acceleration limit for calculation of integral
- Filter ↔ relay assignment
- Time constants for delayed and phase-optimised switching output response
- Further limit values for delayed switching output response and heavy shock detection
- "Safety shut off" limit values for exposition of suddenly occurring high accelerations
- FFT analysis parameter (size, resolution, etc.)

* not certified

Technical data

Electrical data

- Sensor system: MEMS acceleration sensor
- Resolution: 4096 digits / g ($9.81 \text{ m/s}^2 = 1 \text{ g}$)
- Operating voltage range: +11 to +30 VDC (with analogue outputs +18 to +30 VDC)
- Power consumption: $\leq 3 \text{ W}$ (at $V_S = 24 \text{ VDC}$: $I_S = 90 \text{ mA}$, when both switching contacts ON)
- Overvoltage protection and galvanic separation power supply - CANopen - housing
- CAN interface: According to ISO/DIS 11898
- Address setting: Via LMT / LSS
- Terminating resistor: To be implemented separately
- Electrical connection: 2 x connector M12 - (Power supply / CANopen and switching outputs)
3 x connector M12 - (In addition BUS OUT)
- CAN IC voltage rating: Maximum common mode voltage -7 to +12 V
Maximum allowed voltage at pins $\pm 36 \text{ V}$

Environmental data

- Operating temperature range: - 40° C to + 70° C
- Storage temperature range: - 40° C to + 85° C
- Resistance to shock: 250 m/s^2 / 5 ms, according to DIN EN 60068-2-27
- Resistance to vibration: 10 Hz ... 2000 Hz / 80 m/s^2 , according to DIN EN 60068-2-6
- Protection type (DIN 40 050): IP 67 (higher protection types on request)
- Humidity: $\leq 95 \%$, not condensing
- Maximum altitude: 4,000 m
- EMC: EN 61000-6-4 interference emission
EN 61000-6-2 interference immunity
EN 61000-4-2 (ESD)
EN 61000-4-3 (HF field)
EN 61000-4-4 (burst)
EN 61000-4-5 (Surge)
EN 61000-4-6 (HF voltage)
EN 61000-4-8 (Magnetic field)
EN 61000-4-29 (Voltage dips)
IEC 61326-3-2 (Interference immunity for safety systems)
- Further standards: IEC 60068-2-52 - Salt mist test (Type NVA115)
IEC 60068-2-30 - Damp heat, cyclic (Type NVA115)
IEC 60068-2-78 - Damp heat, steady state (Type NVA115)
IEC 60529 - Protection against water jets IPX6 (Type NVA115)
- Housing material: Aluminium (see drawings)
- Weight: 0.4 kg

Technical data

Signal acquisition

- Number of axes: 2
- Value output on analogue output: x and y as separate components or vector sum of x and y (resulting R)
- Number of frequency bands: maximum of 6 (Setting ex works)
- Measuring range: ± 2 g for each axis (higher values on request)
- Sampling frequency: 120 to 800 Hz, depending on the frequency range of according filter
- Accuracy of the measured acceleration value: Standard 5 % (typically)
- Maximum inclination vs. horizon: 15° (at angles $>15^\circ$ an error message will be transferred by CANopen)
- Lower limit frequency: 0.1 Hz (optionally 0.05 Hz)
- Upper limit frequency: 60 Hz
- Set-up time: ca. 3 s

Signal output

- 1 CANopen interface with 4096 digits / g
- 2 analogue outputs 0 (4) ... 20 mA (12-bit resolution) - not certified
- 2 relays for warning and/or alarm function on exceeding limit values

Limit value relay technical data - PLd

- Maximum switching current: 1 A at 30 VDC / VAC, 0.5 A at 60 VDC / VAC
- Maximum switching voltage: 60 VDC / VAC
- Maximum contact resistance ON: 0.5Ω
- Voltage protection between relay- and electronic circuit: 1 kV / minute

Relay control and monitoring

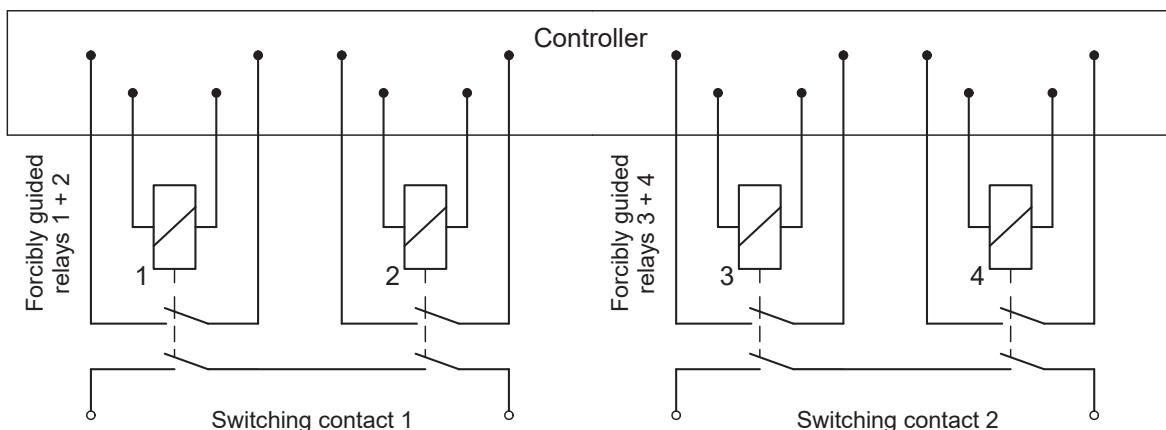

2 relays connected in series form 1 switching contact → safe shut-off even under unfavourable voltage and current conditions. Contact sticking is prevented through a short shut-off time lag in the millisecond range.

Safety parameters

preliminary

Standard EN 13849-1:2015 and EN 13849-2:2015
Vibrationssensor at 70° C

- Category: 2
- PL: d
- CCF: fulfilled

CANopen safety Interface:

- $MTTF_D$ (years): 591
- DC_{avg} [%]: 97,7

Safety switching contacts:

- $MTTF_D$ (years): 226
- DC_{avg} [%]: 95,6

Maximum service life: 20 years
CANopen technical data
CANopen communication profile

- CiA DS 301 version 4.2 (Application Layer)
- EN 50325-5 (Safety protocol)
- CiA DSP 401 version 3.1 (Profile for I/O devices – Part 1: Generic I/O modules)
- CANopen output code: signed 16-bit, unsigned 16-bit resp.

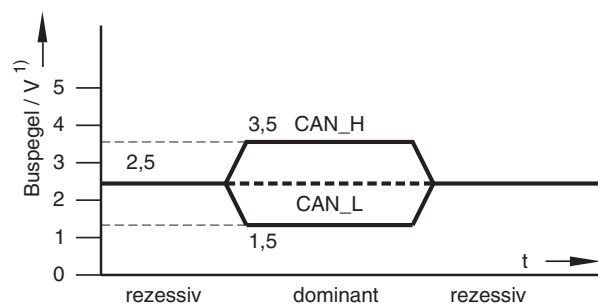
Output level according to ISO/DIS 11898

1) bei Common-Mode-Spannung = 0V

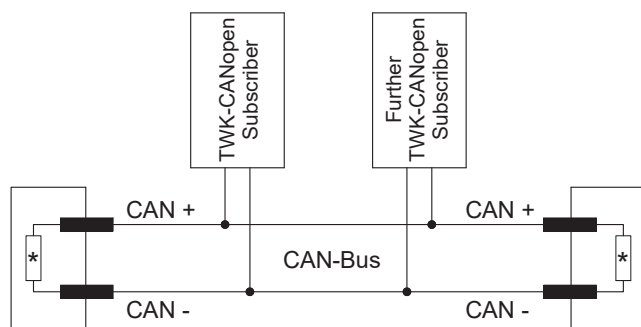
Bus activation according to ISO / DIS 11898

* Terminating resistor (120 Ω)

Order number

NVA	115	-	A	6	2	0	-	2	S3	S3	V1	N	01
-----	-----	---	---	---	---	---	---	---	----	----	----	---	----

Electrical and / or mechanical variants *

01 Standard

Output interface:

N CANopen / CANopen safety

Galvanic separation † (see pages 11 and 12):V1 $-V_S \neq \text{CAN_GND} \neq \text{screen/housing} \rightarrow \text{recommended}$ V2 $-V_S = \text{CAN_GND} \neq \text{screen/housing}$ (on request)V3 $-V_S = \text{CAN_GND} = \text{screen/housing}$ (on request)**Electrical connection (see below and on pages 11 to 13):**

S1 1 x device connector M12, 4/5-pin

S2 2 x device connector M12, 4/5-pin

S3 3 x device connector M12, 4/5-pin

Profile:

S0 not certified

S1 certification in preparation

S3 certified according to the data in this datasheet

Measuring range:2 2 g = approx. 20 m/s² - higher values on request**Number of analogue outputs 0 (4) ... 20 mA:**

0 0, 1, 2 Attention: this is a not certified output at profile S0 / S1

Number of switching outputs:

2 0, 1 or 2 - independent of each other and galvanically separated

Number of frequency filters:

6 1 to a maximum of 6 - set in the factory (frequency bands)

Housing material:

A Aluminium ADC12 (other materials on request)

Design form:

115 Design form 115 mm

120 Design form 120 mm (in preparation)

NVA Vibration sensor / monitor NVA with switching outputs

At the time deliverable versions:**NVA115-A x2x-2S3S3V1Nxx****NVA120: on request****Comments on connector designs:**

Design without analogue outputs: 1 or 2 connectors can be selected for supply voltage + bus connection. The second is intended for BUS-OUT. A further connector contains the safety switching contacts.

Design with analogue outputs: supply voltage + bus connection are located on connector 1 and the analogue outputs on connector 2 (socket). A third connector contains the safety switching contacts. No BUS-OUT is provided in this case.

Special designs with 8-pin connectors and/or sockets with customer-specific assignments are possible on request.

* The basic versions according to the data sheet bear the number 01. Deviations are identified with a variant number and are documented in the factory. The special version in accordance with the table on page 9 is reflected in the variant number.

Order Code format - mating connectors

(to be ordered separately)

- M12, 5-pin, female, A-coded: **STK5GS56**, angled: **STK5WS58**
 M12, 5-pin, male, A-coded: **STK5GP90**, angled: **STK5WP102**
 M12, 4-pin, female, B-coded: **STK5GS67**, angled: **STK5WS87** (5 pole connector is suitable for 4 pole as well)
 (EMC-resistant, metal version)

Further informations
Documentation, EDS file, etc.

- The following documents can be found in the Internet under www.twk.de in the documentation area NVA model (letter "N")
 - Data sheet No. NVA 13482
 - Specification No. NVA 13660
 - Certificate according to EN ISO 13849: NVA14898
 - Test report of certification according to EN ISO 13849: NVA14899
- The following are available on request:
 - EDS file
 - Bit map image file
 - Electrical connection assignment
 - Description of the filter and programming settings
(individually for each pre-set device, therefore on request only)
 - CRC checksum programme for parameterisation
 - Description dokument CRC14076 for CRC checksum programme
 - Test reports for tested standards
- Supply source for the listed CANopen specifications:
 - CAN in Automation (CiA),
 - Kontumazgarten 3, D-90429 Nuremberg
 - (Email: headquarters@can-cia.org, www.can-cia.org)

With this safety design, all changes to the adjustable parameters must be confirmed with a checksum. This checksum must be transmitted to the NVA after changing the parameters. The checksum can be determined using TWK software for a PC/notebook. All alterable parameters are entered in this programme, whereupon the checksum is calculated. Only when the correct checksum appropriate to the set parameters is transmitted to the NVA can the device be set to 'operational' operating status.

When changing parameterization data (limit values for switching contacts, assignments, etc.), the relevant data valid flags will be set to 0 automatically. The data valid flags must then be activated again. This procedure makes sure that no unintentional changes which affect the safety switching contact functions are undertaken by the user.

The user has to take care that all parameters which are programmed, comply to the safety criteria of the application.

(Also see: parameterisation recommendation for NVA / S3 in the NVA 13660 specifications/handbook)

Standard design plug connection and pin assignment for supply and CAN bus

Note: The recommended version is V1 with full galvanic separation. This offers maximum EMC resistance, maximum CANopen data transfer security and thus maximum operating safety.

Versions V2 and V3 are special versions which must be compatible with the structure (topology) of the CANopen bus system in the customer application (→ control system and other CANopen subscribers). Operating safety or data transfer security may otherwise be affected.

This is the contact assignment for the standard version. Other versions may have a different contact assignment. In this case, please observe connection assignment TY enclosed with each device.

Different M12 connector combinations or assignments are possible at the request of the customer.

For the following description and pictorials is valid:

Viewed looking at the PIN side of the connector installed in the NVA.

There is one connector for Bus-In and Bus-Out each for the NVA / S3 without analogue outputs. If there is only Bus-In, the female connector Bus-Out is omitted.

Connector for operating voltage and CAN bus

Viewed looking at the contacts

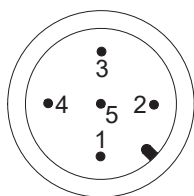

M12, Pins, A-coded

BUS-OUT connector for operating voltage and CAN bus

If available → 3-connector version
Viewed looking at the contacts

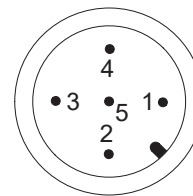

M12, socket, A-coded

V1: CAN_GND and U_B galvanically separated (≠). Screening/housing galvanically separated (≠)

This version is recommended and provides complete galvanic separation. Power supply and CAN_GND is galvanically separated. The housing and the screening of the cable is galvanically separated as well. The screening of the cable comes to the housing of the NOCN via the housing of the mating plug.

PIN	Function
1	CAN GND
2	Operating voltage + V_S
3	Operating voltage - V_S
4	CAN_HIGH (+)
5	CAN_LOW (-)

V2: CAN_GND and U_B not galvanically separated (=). Screening/housing galvanically separated (≠)

This version provides partly galvanic separation. Power supply and CAN_GND are not galvanically separated. The housing and the screening of the cable are galvanically separated from power supply and CAN_GND. The screening of the cable comes to the housing of the NOCN via the housing of the mating plug and/or Pin 1 of the connector. Please note the maximum voltage rating of the CAN interface IC.

PIN	Function
1	Screen (Cable / housing)
2	Operating voltage + V_S
3	Operating voltage - V_S and CAN_GND
4	CAN_HIGH (+)
5	CAN_LOW (-)

Safety - PLd - NVA / S3

Plug connection and pin assignment for supply and CAN bus

V3: CAN_GND and U_B not galvanically separated (=). Screening/housing not galvanically separated (=)

This version provides no galvanic separation. Power supply and CAN_GND are not galvanically separated. The housing and the screening of the cable are not galvanically separated from power supply and CAN_GND. The screening of the cable comes to the housing of the NOCN via the housing of the mating plug and/or Pin 1 of the connector. Please note the maximum voltage rating of the CAN interface IC.

PIN	Function
1	Screen (Cable / housing) - <i>shorted to pin 3 -</i>
2	Operating voltage + V _S
3	Operating voltage - V _S and CAN_GND - <i>shorted to pin 1 -</i>
4	CAN_HIGH (+)
5	CAN_LOW (-)

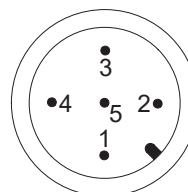

M12, Pins, A-coded

Plug connection and pin assignment for analogue outputs

not certified

Connector for analogue outputs

If available → 3-connector version. In this case the female Bus-Out connector is omitted.

Viewed looking at the contacts

PIN	Connector M12, 4-pin, socket, A-coded
1	Analogue output 1: 0 (4) ... 20 mA
2	Analogue output 2: 0 (4) ... 20 mA
3	Multifunctional pin: NVA-Reset (on request)
4	Reference potential for pins 1 to 3 (- V _S)
5	Not connected

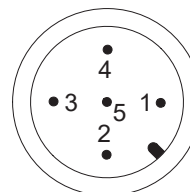

M12, socket, A-coded

Plug connection and pin assignment for safety switching contacts

Connector for safety switching contact

If available

Viewed looking at the contacts

PIN	Connector M12, 4-pin, pins, B-coded
1	Safety contact 1 / (13)
2	Safety contact 1 / (14)
3	Safety contact 2 / (23)
4	Safety contact 2 / (24)

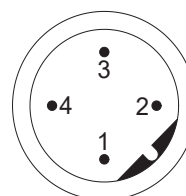

M12, pins, B-coded

Each switching contact is galvanically separated.

(13) / (14): normally open contact of switching contact 1

(23) / (24): normally open contact of switching contact 2

Plug connection and pin assignment

Design of NVA-N02 and NVA-N09

PIN	Connector M12, 5-pin, pins, A-coded
1	Operating voltage + V_S
2	Operating voltage - V_S
3	Do not connect
4	Do not connect
5	Do not connect

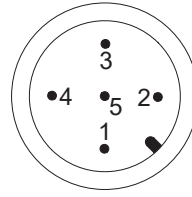

PIN	Connector M12, 5-pin, pins, A-coded
1	Do not connect
2	Do not connect
3	CAN_LOW (-)
4	CAN_HIGH (+)
5	CAN_GND

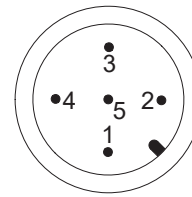

PIN	Connector M12, 4-pin, pins, B-coded
1	Safety contact 1 / (13)
2	Safety contact 1 / (14)
3	Safety contact 2 / (23)
4	Safety contact 2 / (24)

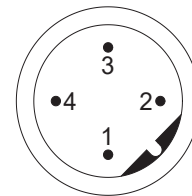

Installation drawing

Type NVA115

Version with 3 connectors

Dimensions in mm

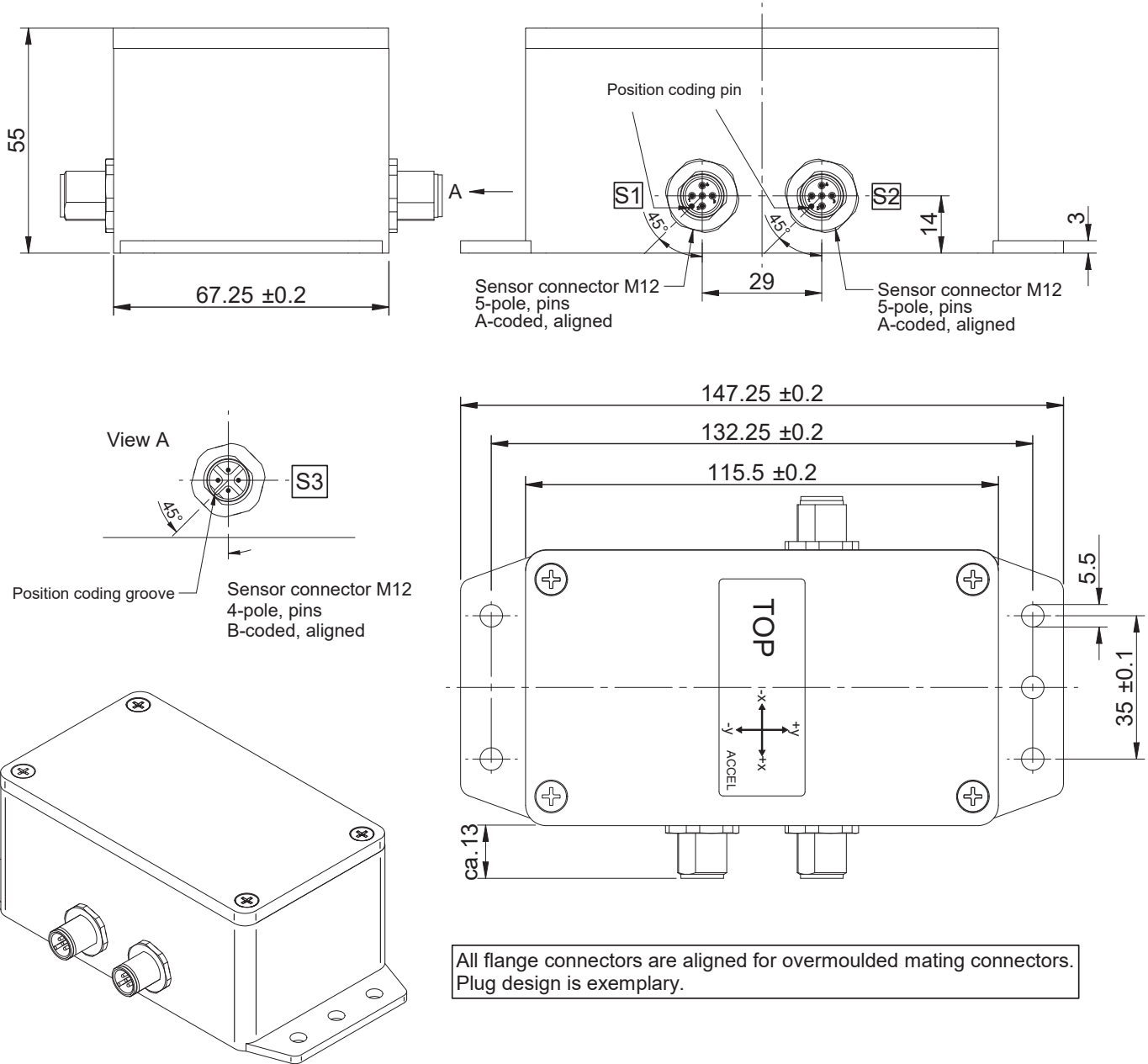

Materials used

Aluminium housing:	ADC12
Connector:	Nickel-plated brass
Sealing rings:	NBR

Installation drawing

Type NVA120

Version with 3 connectors

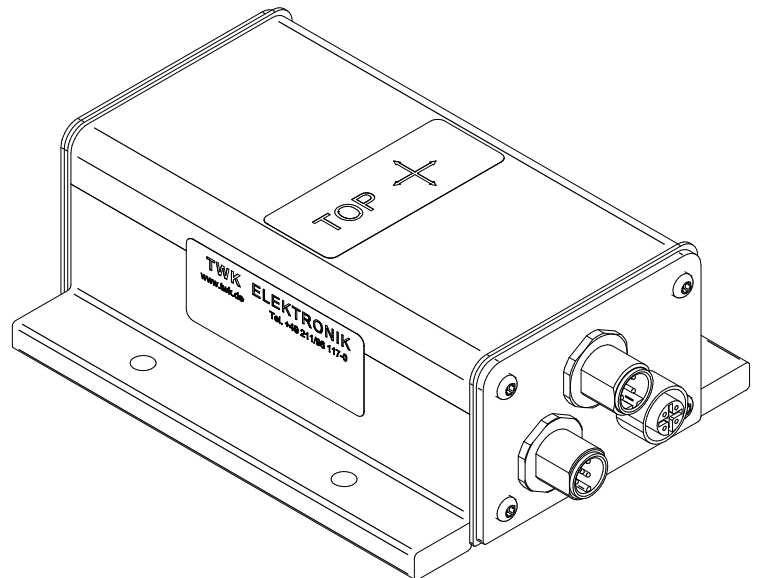
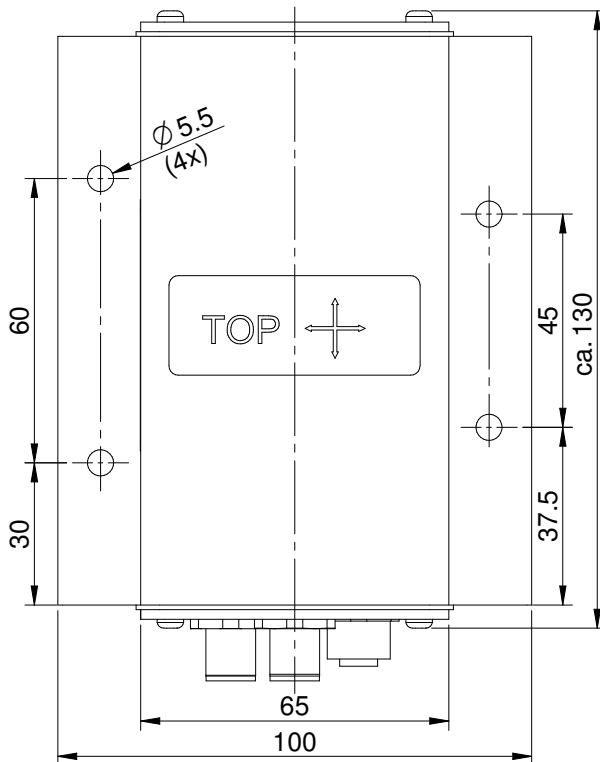
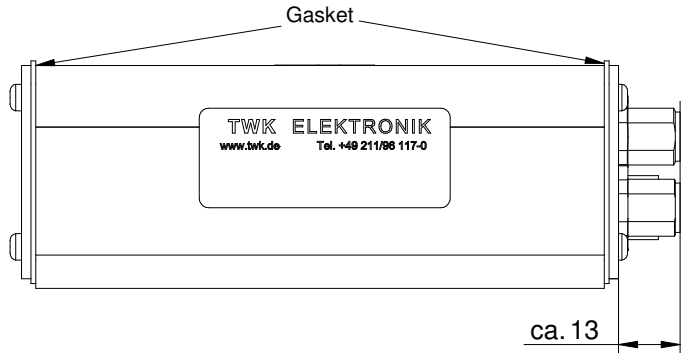
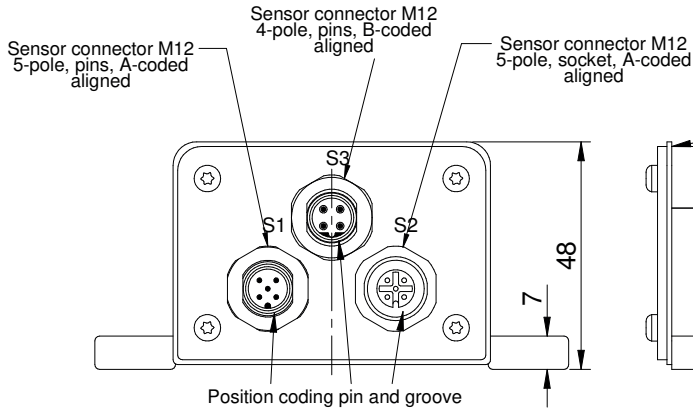

All flange connectors are aligned for overmoulded mating connectors. Plug design is exemplary.



Materials used

- | | |
|--------------------------|------------------------|
| Aluminium housing: | AlMgSi0.5 (EN AW 6060) |
| Aluminium frontplates: | AlMg3 |
| Stainless steel housing: | On request |
| Connector: | Nickel-plated brass |
| Sealing rings: | Silicone |