

MULTI-SPINDLE HEAD - CLASSIC LINE



MULTI H3

TECHNICAL DATA

Lubrication	Grease
Max. drive speed n_2	12,000rpm
Transmission ratio ($n_1: n_2$)	1:4
Max. drive torque M_2	2Nm
Weight	about 4 kg

– Design suitable for nesting applications

STANDARD DESIGN

- 1  Machine Connection
HSK - F63
- 2  32 Spindle distance
-  Output spindle
Whistle Notch Ø6

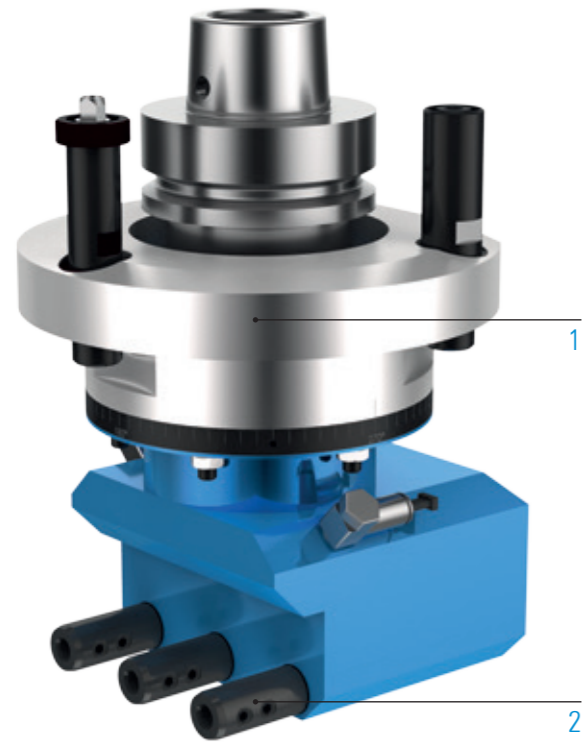

ADDITIONAL OPTIONS: MODULAR DESIGN



MACHINE CONNECTION



 For further information see p. 106



SPINDLE DISTANCE



 Additional spindle distances/ numbers of spindles/ drilling patterns on request

OUTPUT SPINDLE



Whistle Notch
Ø6





 For further information see p. 108

MACHINING



Drilling

SPECIFICATIONS

-  3 Number of output spindles
-  90° Axis angle
-  360° C-angle
-  Grease lubrication

VIDEO



Multi-spindle head - live in the application
Scan QR code or go to:
www.youtube.com/BENZWerkzeugsysteme

ORDER DIRECTLY



Inquiry form:
www.benz-tools.de/en/products