

Globe Control Valve 7027

with integrated positioner

DN 15 to DN 50 - PN 40

Pneumatically operated globe control valve for the control of neutral through to aggressive media.

- High Kvs-values
- Easy to isolate
- Compact design
- All wetted parts made of stainless steel
- For temperatures from -100°C up to +220°C
- Operating pressures up to 40 bar
- Rotable actuators
- Integrated positioner



- Options:
e.g.
- Optical position indicator
 - External I/P-converter Type 8045
 - Ex-electropneumatic positioner (Ex II 2 G EEx ib IIC T6)

Technical information

Body material	Stainless steel 1.4408
Nominal sizes	DN 15 up to DN 50
Connection	Welding ends acc. ISO 1127
Nominal pressure	PN40
Fluid temperature*	-30°C up to +200°C, opt. -100°C up to +220°C
Ambient temperature	Digital positioner -20 (-10) °C up to +75°C Analog positioner -20°C up to +60°C
Leakage acc. IEC 60534-4	Class VI
Packing leakage	ISO FE BH-CC3-SSA1-t(-30°C, +80°C) Test pressure 40 bar

*: Please consider further temperature versions and limits in technical bulletin 32

Materials

Body	Stainless steel 1.4408
Seating seal	PTFE
Bonnet	Brass chrome plated (actuator Ø 50 mm, 80 mm) Aluminium corrosion protected (actuator Ø 125 mm)
Diaphragm actuator	Stainless steel 1.4301/1.4305
Actuator springs	Stainless steel 1.4310 (actuator Ø 80 mm, diaphr.act.) Spring steel wire C, plastic coated (actuator Ø 125 mm)
Packing	PTFE (carbon filled), spring 1.4310
Valve stem	Stainless steel 1.4571, roller burnished
Position indicator	PA Trogamid (clear)

Positioner

For technical information on our positioners please refer to the corresponding data sheets.

Standard version with integrated positioner

Admissible differential pressure with positioner

Digital positioner

DN	Piston Ø	Springs Number	Differential pressure bar	Supply pressure range bar
	mm			
15	80	2	17	4 - 6
20	80	2	17	4 - 6
25	80	1	17	4 - 6
25	125	2	17	3 - 6
25	250	4	17	3 - 6
32	80	1	10	4 - 6
32	125	2	17	3 - 6
32	250	4	17	3 - 6
40	80	1	6	4 - 6
40	125	3	17	4 - 6
40	250	6	17	3 - 6

Reinforced design:

50	80	1	3	4 - 6
50	125	3	11	4 - 6
50	250	6* (Code T)	12	4 - 6
50	250	8	17	4 - 6

* Special springs

Analog positioner

DN	Piston Ø	Spring configuration Number	Differential pressure bar	Supply pressure range bar
	mm			
15	80	2	17	4 - 6
20	80	2	17	4 - 6
25	80	1	12	4 - 6
25	125	2	17	3 - 6
25	250	4	11	2,8 - 6
32	80	1	7	4 - 6
32	125	2	13	3 - 6
32	250	6	17	2,8 - 6
40	80	1	4	4 - 6
40	125	3	11	4 - 6
40	250	6* (Code T)	9	2,8 - 6
40	250	8	15	3,4 - 6

Reinforced design:

50	80	1	2	4 - 6
50	125	3	6	4 - 6
50	250	6* (Code T)	5	4 - 6
50	250	8* (Code W)	9	4 - 6
50	250	10* (Code X)	13	4 - 6
50	250	12	16,9	4 - 6

* Special springs

Admissible differential pressure, direct pressure range

DN	Differential pressure (NC) (bar)		Max. pressure (NO) (bar)		Supply air (bar)		Diaphragm area (cm ²)
	spring range		spring range		spring range		
	0,2 - 1 bar	0,4 - 2 bar	0,2 - 1 bar	0,4 - 2 bar	0,2 - 1 bar	0,4 - 2 bar	
15	17	17	17	17	1,2	2,4	250
20	16	17	17	17	1,2	2,4	250
25	9	17	12	15	1,2	2,4	250
32	5	15	6	13	1,2	2,4	250
40	3	10	2	5	1,2	2,4	250
50	2	6	1	2	1,2	2,4	250

Kvs-Values

DN	linear						equal percentage					
	15	20	25	32	40	50	15	20	25	32	40	50
100%	4,5	7,8	12	18,8	25,7	33,5	3,6	7	12,3	19,7	30	35
63%	-	-	-	-	-	26,5	-	-	-	-	-	22,4
40%	1,8	4,2	6,7	10,3	12,5	-	1,6	2,7	5,3	8,5	12,3	-
25%	1,1	2,9	3,8	-	-	-	1,2	1,8	4,9	-	-	-

Pressure balanced version with integrated positioner

Admissible differential pressure with positioner

DN	Piston Ø mm	Spring configuration Number	Digital positioner 8049		Analog positioner 8047	
			Differential pressure bar	Supply pressure range bar	Differential pressure bar	Supply pressure range bar
50	80	2	17	4 - 6	17	4 - 6

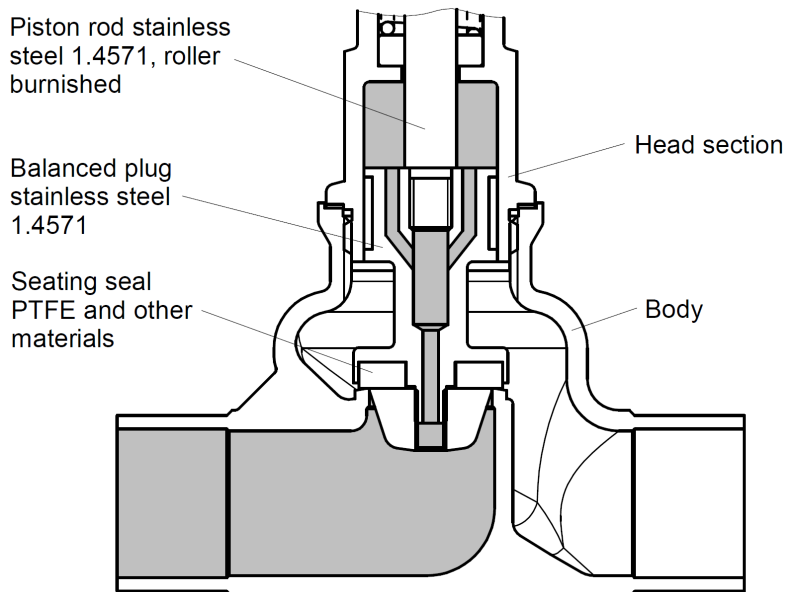

Ordering number system

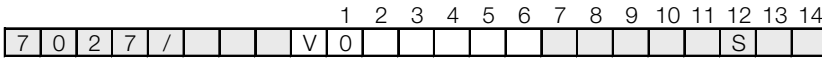

1 - 6 : Please quote all 6 sections.
7 - 14: Quote only if required.

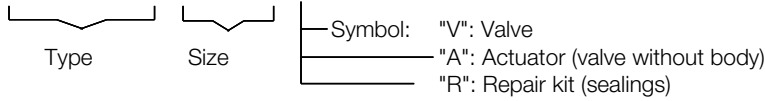

Reinforced version at DN50: "K" at position 22

1.	Body type	2.	Connection	3.	Body materials	4.	Seat material	5.	Positioner	6.	Actuator	7.	Springs
0	globe control valve	H	welding ends acc. ISO 1127	2	stainless steel 1.4408	0	PTFE	6	p/p positioner, Type 8047	1	piston 80 mm	-	without significance
						5	PTFE with 25% glass fibre	7	i/p positioner, Type 8047	2	piston 125 mm	1	spring to open (only with digital positioner)
						7	PEEK	8	i/p positioner with plug connection M12x1, Type 8047	C	diaphragm actuator D250 mm	P	spring set 0,2-1 bar (D 250 mm)
						8	PEEK for applications above 160°C	9	i/p positioner ex-proof (II 2 G Eex ib IIC T6), plug connection M12x1, Type 8047			T	6 springs (D 250 mm)
								C	digital positioner, Type 8049 4 wire			W	8 springs (D 250 mm)
								R	digital positioner Type 8049 2 wire			Y	12 springs (D 250 mm)
								T	digital positioner Type 8049 AS-i version				
								W	digital positioner Type 8049 2 wire, ex-version				
8.	Characteristic	9.	Packing	10.	Kvs-value	11.	Accessories	12.	Special versions	Please declare other remarks and special requests in clear words.			
-	linear	-	standard	-	full Kvs-value	-	without	S	To state if some stations are quoted!				
1	equal percentage	2	packing underneath	1	red. to 40%	6	pilot-valve DN2 230V AC						
				2	red. to 25%	7	pilot-valve DN2 24 DC						
				3	red. to 15%								
				4	red. to 7,5%								
				5	red. to 22,5%								
				6	red. to 10%								

Ordering Example: 7027/020V0H20C1
 Globe Control Valve, nominal size DN 20, welding ends acc. ISO 1127, stainless steel, PTFE seat material, N.C., digital positioner Typ 8049, 4-wire, with position indicator, piston Ø 80 mm, linear characteristic, Kvs-value = 8,8

Globe Control Valve 7027

Standard version with integrated positioner

Dimensions and weights

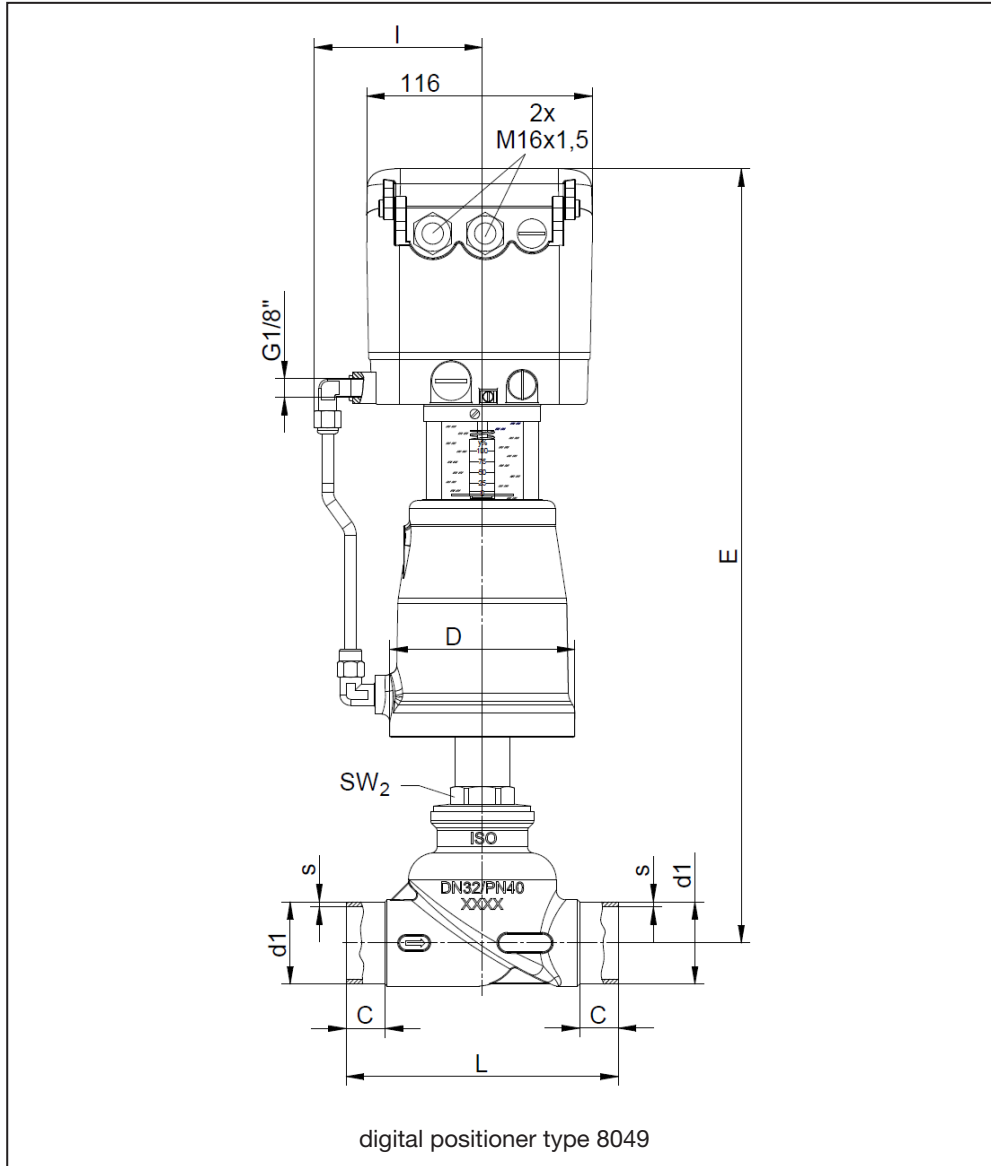

DN	Actuator	d1	s	C	D	E	I	L	SW2	Weight (kg)
15	80	21,3	2	20	96	359	80	95	30	4,4
20	80	26,9	2,3	22	96	367	80	110	30	4,5
25	80	33,7	2,6	21	96	376	80	120	30	4,7
32	80	42,4	2,6	20	96	397	80	140	30	5,0
32	125	42,4	2,6	20	146	419	105	140	30	7,6
40	80	48,3	2,6	22	96	402	80	160	30	5,3
40	125	48,3	2,6	22	146	425	105	160	30	7,9

Reinforced design:

50	80	60,3	2,9	28,0	96	429	80	190	32	5,9
50	125	60,3	2,9	28	146	450	105	190	32	8,5

Globe Control Valve 7027

Standard version with integrated positioner

Dimensions and weights

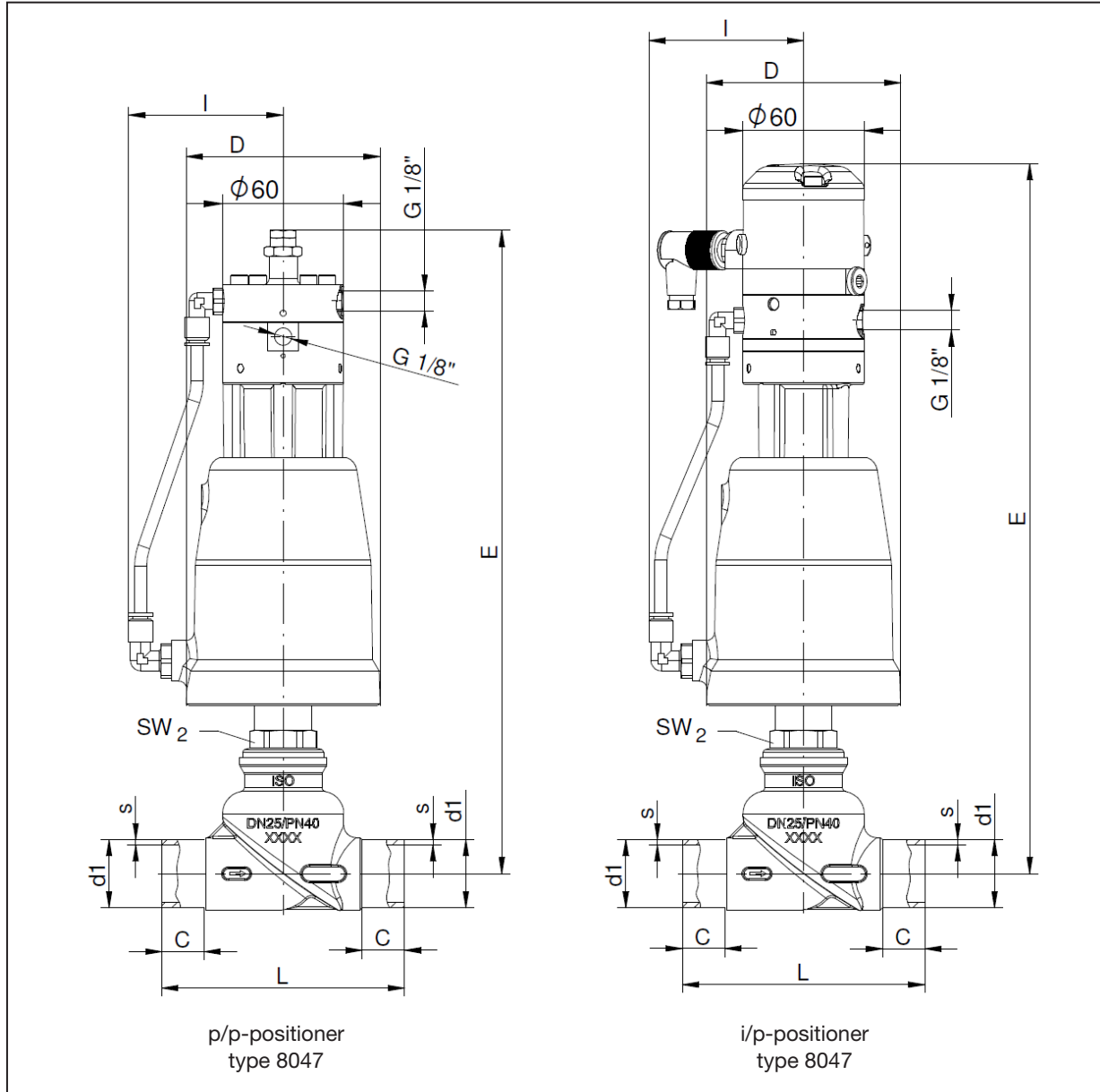

DN	Actuator	d1	s	C	D	E		I	L	SW2	Weight (kg)	
						p/p	i/p				p/p	i/p
15	80	21,3	2	20	96	301	334	77	95	30	3,7	4,0
20	80	26,9	2,3	22	96	309	342	77	110	30	3,8	4,1
25	80	33,7	2,6	21	96	318	351	77	120	30	4,0	4,3
32	80	42,4	2,6	20	96	339	372	77	140	30	4,3	4,6
32	125	42,4	2,6	20	146	363	394	104	140	30	6,9	7,2
40	80	48,3	2,6	22	96	346	379	77	160	30	4,6	4,9
40	125	48,3	2,6	22	146	369	400	104	160	30	7,2	7,5

Reinforced design:

50	80	60,3	2,9	28,0	96	371	404	77	190	32	5,3	5,5
50	125	60,3	2,9	28	146	394	452	104	190	32	7,8	8,1

Globe Control Valve 7027

Standard version with integrated positioner

Dimensions and weights

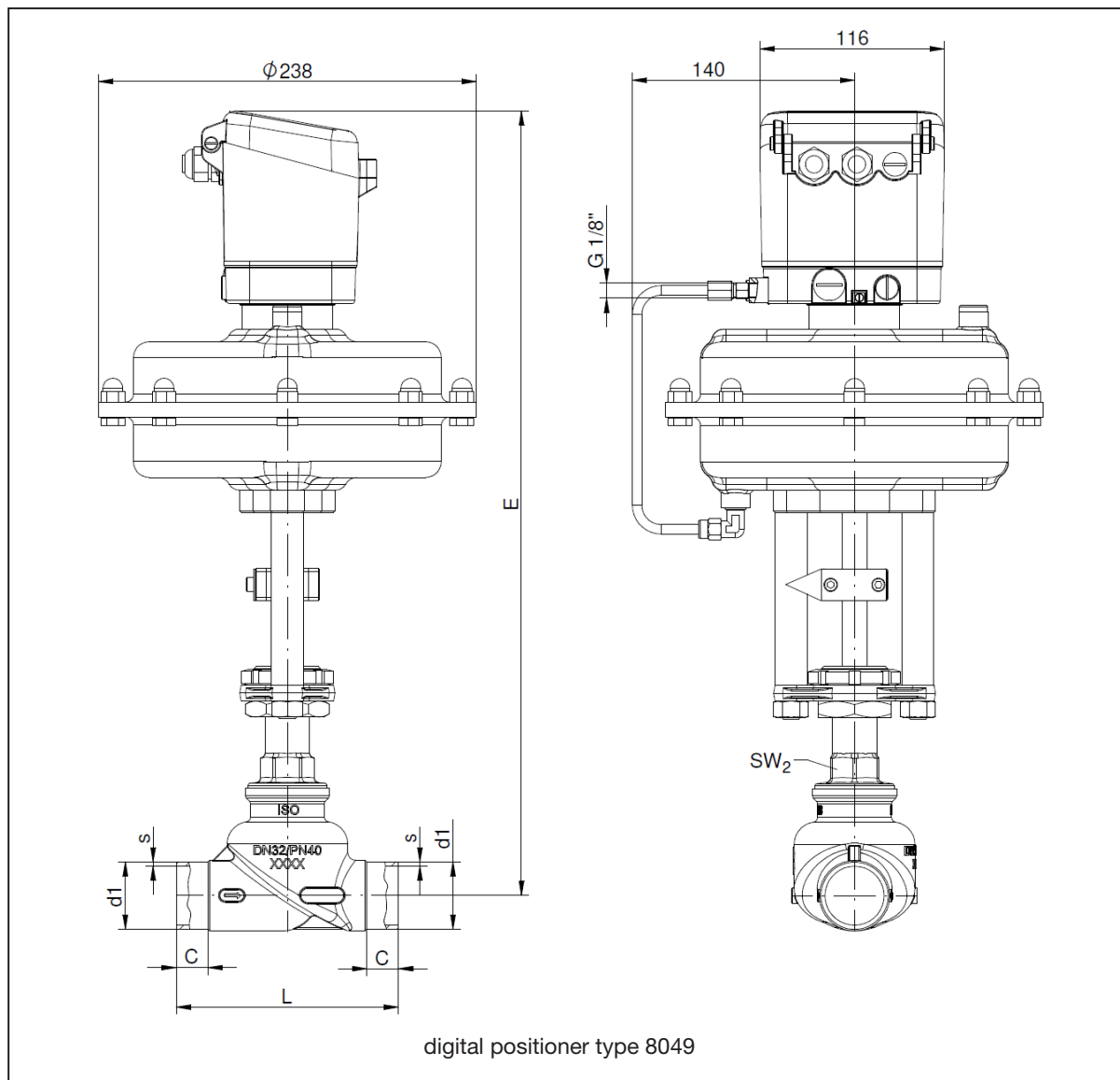

DN	d1	s	C	E	L	SW2	Weight (kg)
15	21,3	2	20	456	95	30	15,6
20	26,9	2,3	22	464	110	30	15,7
25	33,7	2,6	21	473	120	30	15,9
32	42,4	2,6	20	494	140	30	16,0
40	48,3	2,6	22	501	160	30	16,2

Reinforced design:

50	60,3	2,9	28,0	526	190	32	16,5
----	------	-----	------	-----	-----	----	------

Standard version with integrated positioner

Dimensions and weights

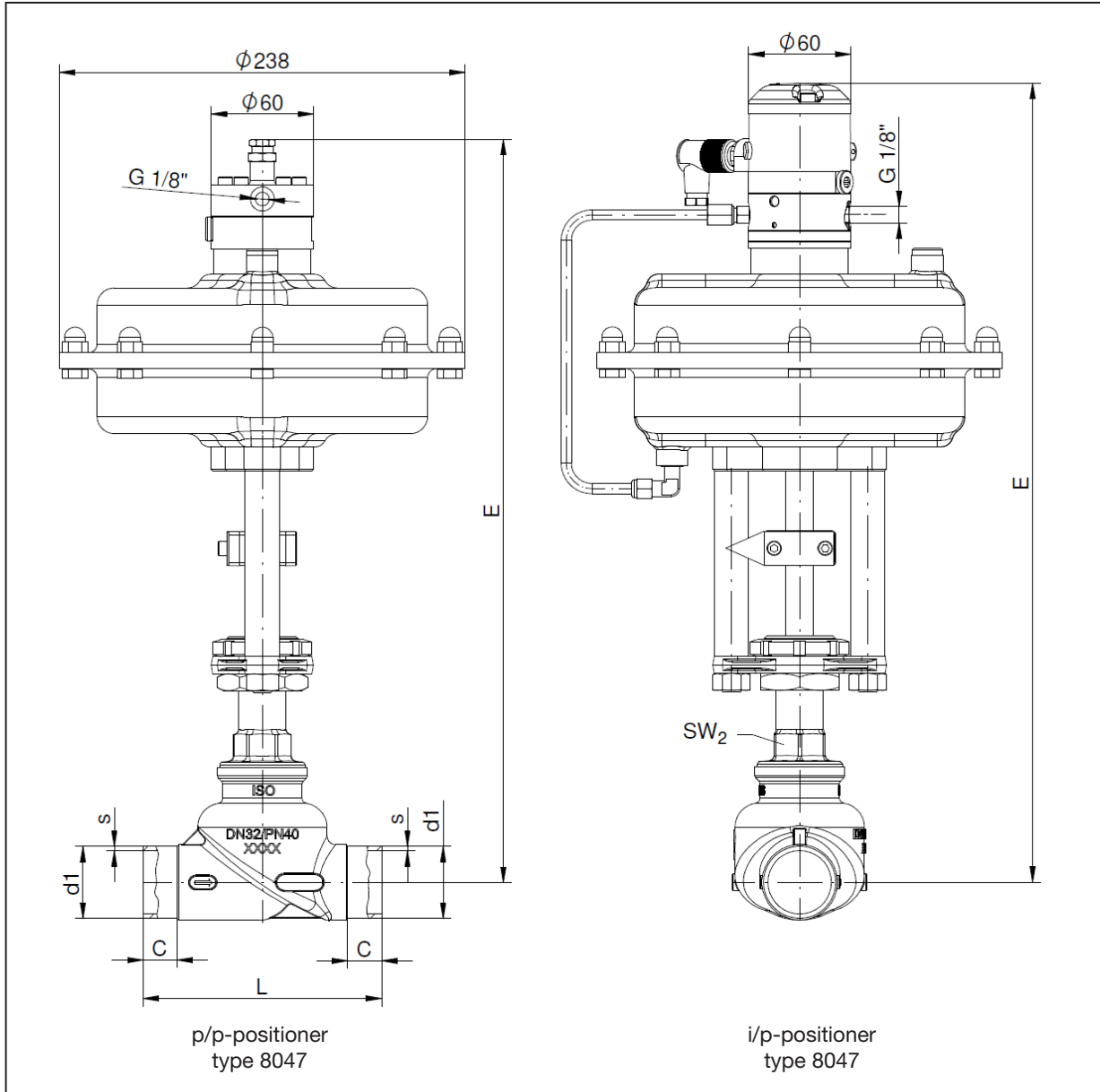

DN	d1	s	C	E		L	SW2	Weight (kg)	
				p/p	i/p			p/p	i/p
15	21,3	2	20	398	431	95	30	14,9	15,2
20	26,9	2,3	22	406	439	110	30	15,0	15,3
25	33,7	2,6	21	415	448	120	30	15,2	15,5
32	42,4	2,6	20	436	469	140	30	15,3	15,6
40	48,3	2,6	22	443	476	160	30	15,5	15,8

Reinforced design:

50	60,3	2,9	28,0	468	501	190	32	15,8	16,1
----	------	-----	------	-----	-----	-----	----	------	------