

Torque Gauge – ATG

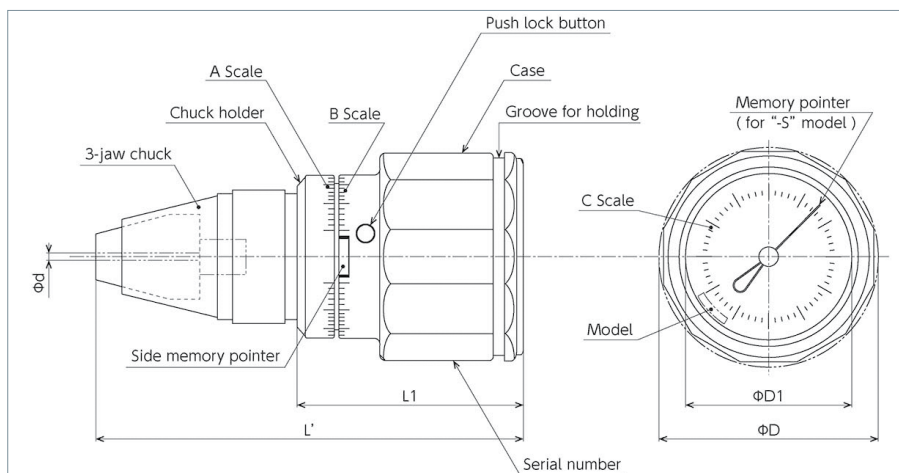

Fig.: ATG with 322



High precision Torque Gauge for measuring of micro torque and tightening

Suitable for fine torque measurements required in inspection, research and assembly of small parts, such as precision instruments, electronic products. There are various application types, e.g. for measuring rotating objects, also for measuring torque on orthodontic springs et al.

Graduation and memory pointer (except smallest model) are on the body side. This ensures excellent visibility.

ATG models have a three-jaw chuck which firmly grasp the object. Main body and chuck are locked when pushing "push lock button". Push lock button makes body and chuck secured while using chuck.



Resin Chuck #322



Steel Chuck #321

- ▶ Accuracy $\pm 2\%$.
- ▶ Bi-directional peak torque measuring – clockwise or counterclockwise.
- ▶ Dial scaled 270 degrees each direction, built-in overload protection.
- ▶ Equipped with aluminium cover and steel chuck (#321) as standard.
- ▶ Models -S have additional memory pointer in top display.
- ▶ Shipped in firm safe box incl. traceable calibration certificate.

Options

INFO

- Resin cover and chuck (#322) for ATG.
- Metric scale (gf-cm) on request.
- Calibration kit ATGTCL24CN.

Note

INFO

When operating with the ATG/BTG (-S) torque gauge series, make sure that at least 10 mm of the object to be measured is clamped in the chuck.

ATG (cN·m)

Model (SI) *	Item No.	Torque Range cN·m	Grad. cN·m	L' mm	ϕD mm	ϕd mm
ATG045CN	T251001	0.05 - 0.45	0.01	90	43.5	1-6.5
ATG09CN	T251004	0.1 - 0.9	0.02	90	43.5	1-6.5
ATG09CN-S	T251004-S					
ATG1.5CN	T251007	0.2 - 1.5	0.02	90	43.5	1-6.5
ATG1.5CN-S	T251007-S					
ATG3CN	T251010	0.3 - 3.0	0.05	90	43.5	1-6.5
ATG3CN-S	T251010-S					
ATG6CN	T251013	0.6 - 6.0	0.1	90	43.5	1-6.5
ATG6CN-S	T251013-S					
ATG12CN	T251016	1.0 - 12	0.2	90	43.5	1-6.5
ATG12CN-S	T251016-S					
ATG24CN	T251019	3.0 - 24	0.5	90	43.5	1-6.5
ATG24CN-S	T251019-S					

ATG (ozf-in)

Model *	Item No.	Torque Range ozf-in	Grad. ozf-in	L' mm	ϕD mm	ϕd mm
ATG06Z	T251003	0.06 - 0.6	0.01	90	43.5	1-6.5
ATG1.5Z	T251006	0.2 - 1.5	0.02	90	43.5	1-6.5
ATG1.5Z-S	T251006-S					
ATG2.4Z	T251009	0.3 - 2.4	0.05	90	43.5	1-6.5
ATG2.4Z-S	T251009-S					
ATG4.5Z	T251012	0.5 - 4.5	0.1	90	43.5	1-6.5
ATG4.5Z-S	T251012-S					
ATG9Z	T251015	1.0 - 9.0	0.2	90	43.5	1-6.5
ATG9Z-S	T251015-S					
ATG18Z	T251018	2.0 - 18	0.5	90	43.5	1-6.5
ATG18Z-S	T251018-S					
ATG36Z	T251021	4.0 - 36	0.5	90	43.5	1-6.5
ATG36Z-S	T251021-S					

* Models with suffix -S have an additional memory pointer in the upper display; except for ATG-045CN and ATG06Z: these require only a very small torque, therefore no lateral memory indicator and no option for the upper memory pointer available.

