

Absolute Monotour/Multitour shaft encoder models TBN/TRN with CANopen Safety SIL2 and CANopen

Document no.: TBN/TRN 14271 DE
Date: 07.08.2019

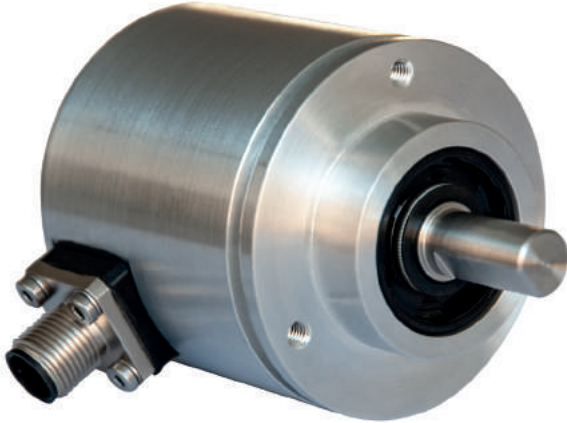

- **Sturdy design for tough applications, e.g. crane technology, construction machinery and mobile working equipment**
- **Magnetic sensor systems**
- **Measuring range**
TBN: **16.384 steps/ 360°**
TRN: **67.108.864 steps**
(16.384 S / U x 4096 revolutions)
- **14-Bit position data and speed signal**
- **Protection grade IP65/IP66**
(IP69K with optional housing potting)
- **Interfaces:**
CANopen Safety SIL2,
CANopen
(CiA DS 406 Encoder Profile, 4.0.2)

Structure

- Sturdy housing made from seawater-resistant aluminium (AlMgSi1 - 3.2315) or stainless steel (material: 1.4305 or 1.4404)
- Constructions with Ø 42, Ø 50 and Ø 58 mm as well as special constructions (application-dependent)
- Magnetic sensor systems for position detection
- Recording of rotations via an absolute Multitour transmission in the TRN model
- Electrical connections via connector M12x1 (Bus In and Bus Out option) or via cable
- Optional housing potting to meet IP69K requirements
- Interface as Standard CANopen or as CANopen Safety SIL2 in accordance with IEC61508

Function

A positive-locking mechanical connection between the customer's shaft and the sensor shaft ensures that the magnet in the sensor shaft precisely reflects the rotation of the customer's shaft.

With the TBN model, one rotation (i.e. max. 16,384 steps) is recorded.

With the subsequent absolute transmission, the TRN shaft encoder reaches a measuring range of up to 4096 rotations.

The position and speed values (PDO - Process Data Object) are output via the CANopen protocol.

With the CANopen Safety protocol, both the position value and the speed value (SRDO - Safety Relevant Data Object) meet the requirements of SIL2. The values for the redundant system are compared and checked for plausibility. If the check is positive, the output will be normal and bit-inverted.

Comprehensive checks using CRC, timing monitoring, voltage monitoring etc. ensure that reliable position and speed values are output.

The speed value can be parameterised via the gate time (1 to 1000 ms) depending on the specific application.

In the event of a fault, emergency protocols are issued and a fault listing is created. The target function here is to move to a safe state in the event of a fault. This is also referred to as the functional safety of the shaft encoder.

Absolute Monotour/Multitour shaft encoder models TBN/TRN with CANopen Safety SIL2 and CANopen

Technical data

Electrical data

■ Sensor system:	Magnetic sensor systems
■ Resolution:	TBN: 14 Bit (16.384 steps/ 360°) TRN: 14 Bit + 12 Bit (26 Bit)
■ Speed value:	In addition to the position signal, a digits/gate time speed signal is also generated, which can be adapted by the customer via an adjustable gate time for the application.
■ Speed value data format:	16 Bit
■ Gate time:	1 to 1000 ms
■ Internal sampling frequency:	1ms
■ Maximum speed:	approx. 120 rpm (at 14 Bit and gate time 1000 ms)
■ Total step count:	TBN: 16.384 steps TRN: 67.108.864 steps (16.384 steps / resolutions x 4096 revolutions)
■ Operating voltage:	9 to 36 VDC with reverse-polarity protection and short-circuit protection
■ Power consumption:	TBN: < 1 W TRN: < 1,5 W
■ Code sense:	CW* or CCW**, parameterisable
■ Reference value:	0 to (total step count -1)
■ Accuracy TBN:	± 0,05 %
■ Accuracy TRN:	± 0,2 %
■ Reproducibility:	± 0,02 %
■ Temperature drift:	< 0,02°/K

*) CW = increasing output value when shaft rotating clockwise

**) CCW = increasing output value when shaft rotating anti-clockwise

CANopen / CANopenSafety SIL2 overview of specifications

CiA DS301	CANopen Application Layer and Communication Profile, Version 4.1
CiA DS406	CANopen - Device Profile for Encoders, Version 4.0.2
CiA DS305	CANopen - Layer Setting Services and Protocol (LSS)
DIN EN 50325-5: 2016-06	Industrial communication sub-system based on ISO 11898 (CAN) - Part 5: Functionally safe communication based on EN 50325-4
■ CAN-Interface:	according to ISO/DIS 11898
■ Address setting:	over LMT / LSS or SDO
■ Terminating resistance:	to be implemented separately
■ Max. transmission length:	200 m, without galvanic isolation, see also CiA DS301 and information on the structure (see page 7)
■ Bootloader function:	yes System prerequisites: - PCAN-USB adapter (www.peak-system.com) including USB cable for PC connection - CANopen tester TWK software, hex file for updating - Shaft encoder connecting cable
■ Number of PDOs:	2 Tx
■ Number of SRDOs:	2 Tx (CANopen Safety SIL2)
■ PDO-Modes:	sync, async, cyclic, acyclic
■ SRDO-Mode:	cyclic (CANopen Safety SIL2)
■ Variables PDO-Mapping:	no
■ Emergency Message:	yes
■ Heartbeat:	yes
■ No. of SDOs:	1 Rx / 1 Tx
■ Device Profile:	CiA DSP 406 Version 4.0.2

The profile details are described in detail in the user manual NOC13100. The CRC calculation is carried out using the CRC DS304 program, which can be provided to the customer on request.

Absolute Monotour/Multitour shaft encoder models TBN/TRN with CANopen Safety SIL2 and CANopen

Technical data

Overall system and safety

- Duty cycle (rise time) supply voltage: 500 ms (10 % to 90 %)
- Information density: up to 10 000 messages / s
- Storage cycle time: 3 s per memory cycle
- Setup Time: ~ 2 s @ T ≥ +20 °C
- Time between the detection of a fault and the output of the emergency message: 100 ms (voltage supply)
5 s (RAM test, all individual bits ok)
2 s (ROM test (within setup time))
- Certificate number: Following provision of the certification documents
- Safety standard: IEC 61508: 2017: Functional Safety of Electrical/Electronic/Programmable Electronic Safety-related Systems
- EDS file: The EDS file is available on request.

Mechanical data

- Operating speed: max. 1.000 min⁻¹ (with shaft sealing ring)
max. 10.000 min⁻¹ (with Nilosring)
- Angular acceleration: 10⁵ rad/s² max.
- Moment of inertia (rotor): 20 gcm²
- Operating torque: ≤ 8 Ncm
- Starting torque: ≤ 3 Ncm
- Permissible shaft load: 250 N axial, 250 N radial (Ø 58 and Ø 50 - design)
50 N axial, 50 N radial (Ø 42 - standard design, other values optional)
- Bearing service life: ≥ 10⁹ rotations*
- Mass: TBN Ø 58: Aluminium approx. 0,3 kg, Steel approx. 0,4 kg
TRN Ø 58: Aluminium approx. 0,5 kg, Steel approx. 0,7 kg
Weight specifications for the other constructions on request.

*) This value applies for maximum shaft load

Ambient data

- Working temperature range: - 40 °C to + 85 °C
- Storage temperature range: - 20 °C to + 60 °C (due to packaging)
- Resistance:
 - to shock: 250 m/s², 6 ms, in 3 axes every 100x (higher values optional)
DIN EN 60068-2-27
 - to vibration: 100 m/s², 5 Hz ... 2000 Hz, in 1 h in 3 axes, (higher values optional)
DIN EN 60068-2-6
- EMC standards: DIN EN 61 000 - 6 - 2; 2013, immission (Burst/ESD/etc.)
DIN EN 61 000 - 6 - 4; 2013, emission
- Protection grade (DIN EN 60529): Shaft side: IP66 - shaft sealing ring, IP65 - Nilos ring
Housing side: IP67, IP69K optional (housing potting)
(For higher degrees of protection up to IP69K, please contact our technical contact persons)

Absolute Monotour/Multitour shaft encoder models TBN/TRN with CANopen Safety SIL2 and CANopen

Bus connection, output level and data profile

Bus connection as per ISO / DIS 11898

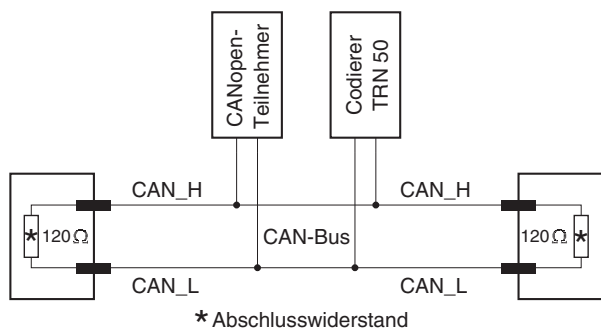

Output level as per ISO / DIS 11898

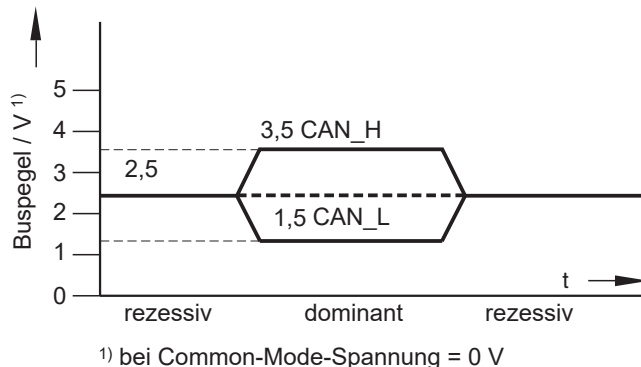

Data profile CANopen

PDO1/2 (position and speed)

PDO 1 / PDO 2

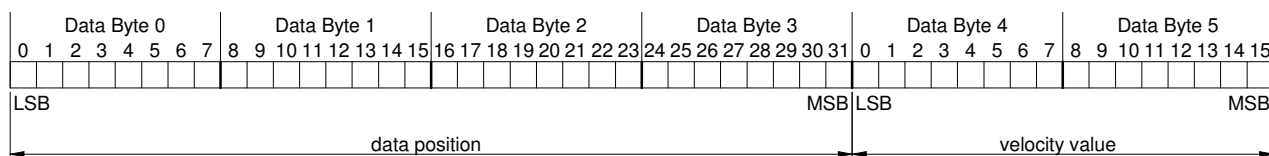

Data profile CANopen Safety SIL2 (model TRN)

SRDO1 (position) – normal and bit-inverted

SRDO 1

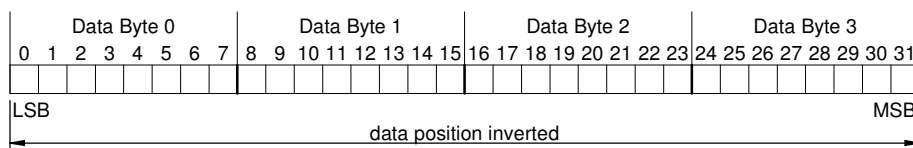
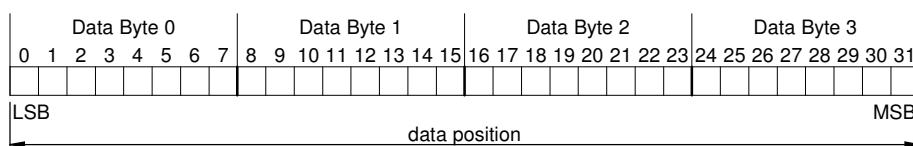

SRDO2 (speed) – normal and bit-inverted (models TRN and TBN)

SRDO 2

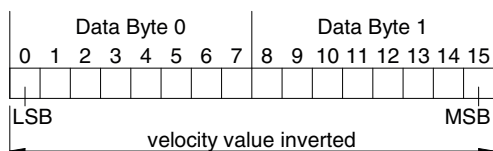
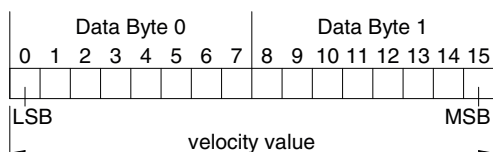

Absolute Monotour/Multitour shaft encoder models TBN/TRN with CANopen Safety SIL2 and CANopen

Schematic diagrams TBN and TRN (construction Ø 58 – CANopen shown)

Model: TBN

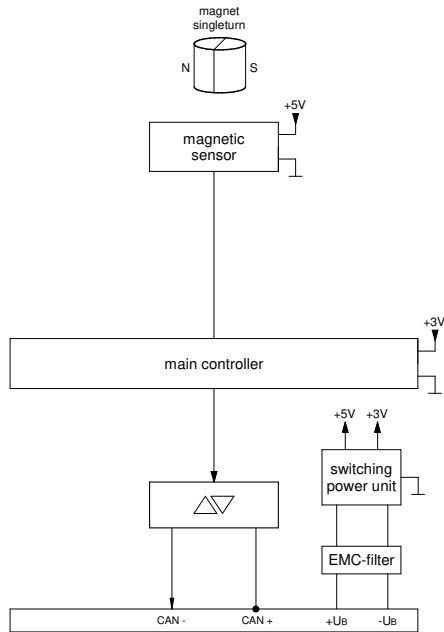

Model: TRN

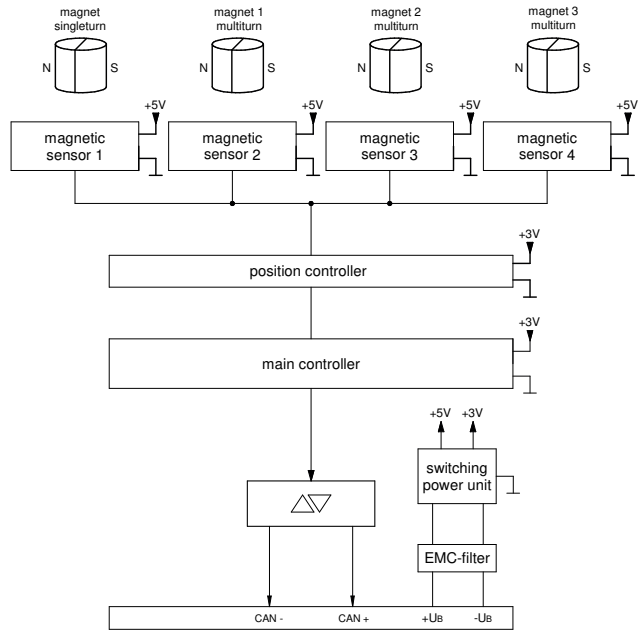

Absolute Monotour/Multitour shaft encoder models TBN/TRN with CANopen Safety SIL2 and CANopen

Electrical connection, mating connector, contact configuration M12x1, note

Electrical connection

- TBN Ø 58 / TRN Ø 58: With connector M12x1, pin, 5-pin, A-coded (standard: Galvanic concept: V3)
With 2 connectors M12x1, pin and socket, 5-pin, A-coded, Bus In and Bus Out
With radial cable, twisted pair, e.g. 2 x 2 x 0.25 mm², shielded (standard)
- The connection assignment TYxxxxx is part of the scope of supply and is included with each device.

Mating connector (to be ordered separately)

Order identification	STK5GS56	STK5GP90	STK5WS58	STK5WP102	STK5GS107	STK5GP106
Type	M12x1	M12x1	M12x1	M12x1	M12x1	M12x1
Pole number	5	5	5	5	5	5
Contact design	Socket, A-coded	Pin, A-coded	Socket, A-coded	Pin, A-coded	Socket, A-coded	Pin, A-coded
Connector design	straight	straight	angled	angled	straight	straight
Housing material	Brass, nickel-plated	Brass, nickel-plated	Brass, nickel-plated	Brass, nickel-plated	Steel	Steel
Cable ø (mm)	6 - 8	6 - 8	6 - 8	6 - 8	5,5 - 8,6	5,5 - 8,6
Connection type	Screws	Screws	Screws	Screws	Screws	Screws
Degree of protection class	IP67	IP67	IP67	IP67	IP67	IP67
Shielding	On the housing (V3)	On the housing (V3)	On the housing (V3)	On the housing (V3)	On the housing (V3)	On the housing (V3)
Max. wire size (mm ²)	0,75	0,75	0,75	0,75	0,75	0,75

Please note: If angled mating connectors are used, please specify the position of the coding groove so that the device connectors can be aligned accordingly.

Contact configuration of the M12x1 5-pin connector, connector side view

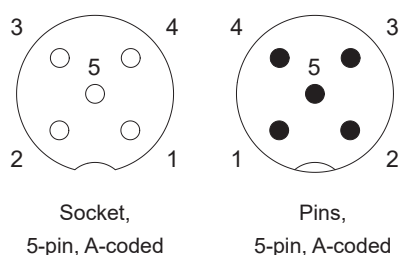

Note:

The 5-pin M12x1 connector is used as standard. There are three different galvanic concepts for potential isolation (V1-V3) (see also page 7).

Absolute Monotour/Multitour shaft encoder models TBN/TRN with CANopen Safety SIL2 and CANopen

Galvanic potential isolation: $-V_s$, CAN_GND and housing/cable shielding

The description of the different versions of galvanic potential (V1 to V3) relates exclusively to the interrelationships between the individual potentials ($-V_s$, CAN_GND and housing/cable shielding), i.e. whether or not they are galvanically connected. The connection assignment (TYxxxx) should be observed. This connection assignment is included with each device and a copy can be requested as needed.

V1: CAN_GND, $-V_s$ and housing/cable shielding galvanically isolated

This version has complete galvanic isolation. The housing/cable shielding are galvanically isolated from $-V_s$ and CAN_GND, and $-V_s$ and CAN_GND are also galvanically isolated from one another. The cable shielding is galvanically connected to the housing via the connector housing

PIN	Function
1	CAN GND
2	Operating voltage + V_s
3	Operating voltage - V_s
4	CAN_H
5	CAN_L

V2: CAN_GND and $-V_s$ not galvanically isolated, cable shielding galvanically isolated

This version has partial galvanic isolation: The housing/cable shielding are galvanically isolated from $-V_s$ and CAN_GND. But: $-V_s$ and CAN_GND are not galvanically isolated from one another. The cable shielding is assigned to pin 1.

PIN	Function
1	Shielding
2	Operating voltage + V_s
3	Operating voltage - V_s and CAN-GND
4	CAN_H
5	CAN_L

V3: CAN_GND, $-V_s$ and cable shielding/housing not galvanically isolated

This version has no galvanic isolation: The housing/cable shielding are not galvanically isolated from $-V_s$ and CAN_GND, and $-V_s$ and CAN_GND are not galvanically isolated from one another.

PIN	Function
1	Shielding – short-circuited with PIN 3
2	Operating voltage + V_s
3	Operating voltage - V_s and CAN-GND, short-circuited with PIN 1
4	CAN_H
5	CAN_L

Absolute Monotour/Multitour shaft encoder models TBN/TRN with CANopen Safety SIL2 and CANopen

Order identification for design Ø 58

TRN	58 -	KP	A	16384	R	4096	S4	S1	V1	N	01
-----	------	----	---	-------	---	------	----	----	----	---	----

01 **Electrical and mechanical versions***

Output signal:

N CANopen-Interface

Galvanic Isolation (see also [page 7](#))

V1 $-V_s \neq \text{CAN_GND} \neq \text{Shield/housing}$

V2 $-V_s = \text{CAN_GND} \neq \text{Shield/housing}$

V3 $-V_s = \text{CAN_GND} = \text{Shield/housing}$

Electrical connection (see also [page 7](#))

→ Combine S, T, K or L and quantity

- 1 1 x Device connector or cable
- 2 2 x Device connector or cable (Bus In/ Bus Out)
- S Device connector M12, 5-polig, radial
- T Device connector M12, 5-polig, axial
- K Cable, 1m, radial (other lengths on request)
- L Cable, 1m, axial (other lengths on request)

CANopen-Interface-Version:

C3 Standard CANopen, Profile version 4.0.2

S4 CANopen Safety SIL2, Profile version 4.0.2

Measuring range:

4096 Rotations (not applicable for TBN)

Output code:

R Binary

Resolution:

4096 Steps / resolutions - 12 Bit

8192 Steps / resolutions - 13 Bit

16384 Steps / resolutions - 14 Bit

Housing material:

A Aluminium AlMgSi1 - 3.2315

S Steel - 1.4305

V Steel - 1.4404

Flange and shaft:

K Clamped flange, shaft Ø 10 mm with flattened areas**

KF Clamped flange, shaft Ø 10 mm with feather key**

KP Clamped flange, shaft Ø 10 mm with disk spring**

KZ Clamped flange, shaft for measurement gear ZRS see data sheet [ZRS 11877](#) (design Ø 58)**

S Synchroniser flange, shaft Ø 6 mm

SR Synchroflansch, Klemmwelle für Ø 12 mm for torque support [ZMS 12939](#) (design Ø 58)

SP Synchroniser flange, shaft Ø 12 mm with disk spring

Design form:

58 Design form Ø 58 mm

Model:

TBN Monotour rotary encoder with CANopen-Interface

TRN Multitour rotary encoder with CANopen-Interface

* According to the datasheet, the basic (standard) versions are indicated by the number 01. Deviations are indicated by a version number and are documented at the factory.

** Standard version with shaft sealing ring

Absolute Monotour/Multitour shaft encoder models TBN/TRN with CANopen Safety SIL2 and CANopen

Order identification for design Ø 50

TRN	50 -	K	A	16384	R	4096	S4	S1	V1	N	01
-----	------	---	---	-------	---	------	----	----	----	---	----

01 **Electrical and mechanical versions***

Output signal:

N CANopen-Interface

Galvanic Isolation (see also [page 7](#))

V1 $-V_s \neq \text{CAN_GND} \neq \text{Shield/housing}$

V2 $-V_s = \text{CAN_GND} \neq \text{Shield/housing}$

V3 $-V_s = \text{CAN_GND} = \text{Shield/housing}$

Electrical connection (see also [page 7](#))

→ Combine S, T, K or L and quantity

- 1 1 x Device connector or cable
- 2 2 x Device connector or cable (Bus In/ Bus Out)
- S Device connector M12, 5-polig, radial
- T Device connector M12, 5-polig, axial
- K Cable, 1m, radial (other lengths on request)
- L Cable, 1m, axial (other lengths on request)

CANopen-Interface-Version:

C3 Standard CANopen, Profile version 4.0.2

S4 CANopen Safety SIL2, Profile version 4.0.2

Measuring range:

4096 Rotations (not applicable for TBN)

Output code:

R Binary

Resolution:

4096 Steps / resolutions - 12 Bit

8192 Steps / resolutions - 13 Bit

16384 Steps / resolutions - 14 Bit

Housing material:

A Aluminium AlMgSi1 - 3.2315

S Steel - 1.4305

V Steel - 1.4404

Flange and shaft:

K Clamped flange, shaft Ø 10 mm with flattened areas**

KP Clamped flange, shaft Ø 10 mm with disk spring**

S Synchroniser flange, shaft Ø 12 mm with disk spring

Design form:

50 Design form Ø 50 mm

Model:

TBN Monotour rotary encoder with CANopen-Interface

TRN Multitour rotary encoder with CANopen-Interface

* According to the datasheet, the basic (standard) versions are indicated by the number 01. Deviations are indicated by a version number and are documented at the factory.

** Standard version with shaft sealing ring

Absolute Monotour/Multitour shaft encoder models TBN/TRN with CANopen Safety SIL2 and CANopen

Order identification for design Ø 42

TRN	42 -	S	S	16384	R	4096	S4	K	N	01
										01 Electrical and mechanical versions*
										Output signal: N CANopen-Interface
										Electrical connection: K Cable, 1m, radial (other lengths an request) L Cable, 1m, axial (other lengths an request)
										CANopen-Interface-Version: C3 Standard CANopen C3, Profile version 4.0.2 S4 CANopen Safety SIL2, certified, Profile version 4.0.2
										Measuring range: 4096 4096 rotations (not applicable for TBN)
										Output code: R Binary
										Resolutions: 4096 Steps / resolution - 12 Bit 8192 Steps / resolution - 13 Bit 16384 Steps / resolution - 14 Bit
										Housing material: A Aluminium - 3.2315 S Steel 1.4305 V Steel 1.4404
										Flange and shaft: S Synchroniser flange, shaft Ø 6 mm
										Design form: 42 Design form Ø 42
										Model: TBN Monotour rotary encoder with CANopen-Interface TRN Multitour rotary encoder with CANopen-Interface

* According to the datasheet, the basic (standard) versions are indicated by the number 01. Deviations are indicated by a version number and are documented at the factory.

Absolute Monotour/Multitour shaft encoder models TBN/TRN with CANopen Safety SIL2 and CANopen

Allocation of flange type, bearing sealing, speed and degree of protections (Design Ø58)

Flange	Performance	rpm	Protection grade
Clamped flange K, KF, KP	Sealing ring	max. 1000 min ⁻¹	IP67
			IP69K - housing side (optional)
Clamped flange KZ	Sealing ring	max. 1000 min ⁻¹	IP67
			IP69K - housing side (optional)
Synchroniser flange S, SP	Sealing ring	max. 1000 min ⁻¹	IP67
	Nilos ring	max. 10.000 min ⁻¹	IP65

Absolute Monotour/Multitour shaft encoder models TBN/TRN with CANopen Safety SIL2 and CANopen

Accessories (please note the shaft encoder version)

Play-free bellows coupling BKM 26 / x - y

x and y: Bore diameter for shaft support

See data sheet [BKM 11995](#)

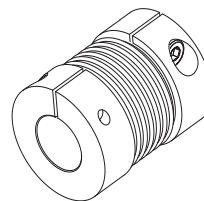

Play-free bellows coupling BKK 32 / x - y

x and y: Bore diameter for shaft support

See data sheet [BKK 11840](#)

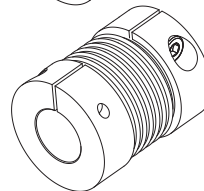

Play-free clamp coupling KK14S / x - y (without groove)

x and y: Bore diameter for shaft support

See data sheet [KK 12301](#)

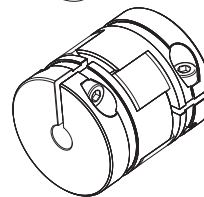

Play-free clamp coupling KK14N / x - y (with groove)

x and y: Bore diameter for shaft support

See data sheet [KK 12301](#)

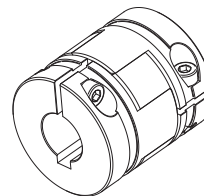

Mounting brackets KL 66-2-S

Mounting brackets for shaft encoder assembly.

See data sheet [MZ 10111](#)



Torque support ZMS58

Torque support/stator coupling. Suitable for use as a shaft encoder bracket for the clamping shaft version, for the offsetting of radial and axial drive shaft play for Ø 58 mm shaft encoders.

See data sheet [ZMS 12939](#)

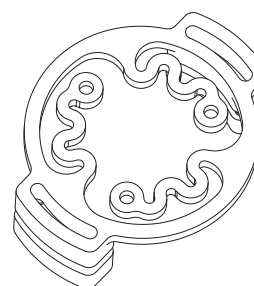

Play free measuring wheel ZRS

Play-free measuring wheel ZRS for Ø 58 mm shaft encoders for live ring applications.

See data sheet [ZRS 11877](#)

Absolute Monotour/Multitour shaft encoder models TBN/TRN with CANopen Safety SIL2 and CANopen

Installation drawings (dimensions in mm)

Order identification: **TBN58 - SA 16384 R S4 S1 V1 N01**

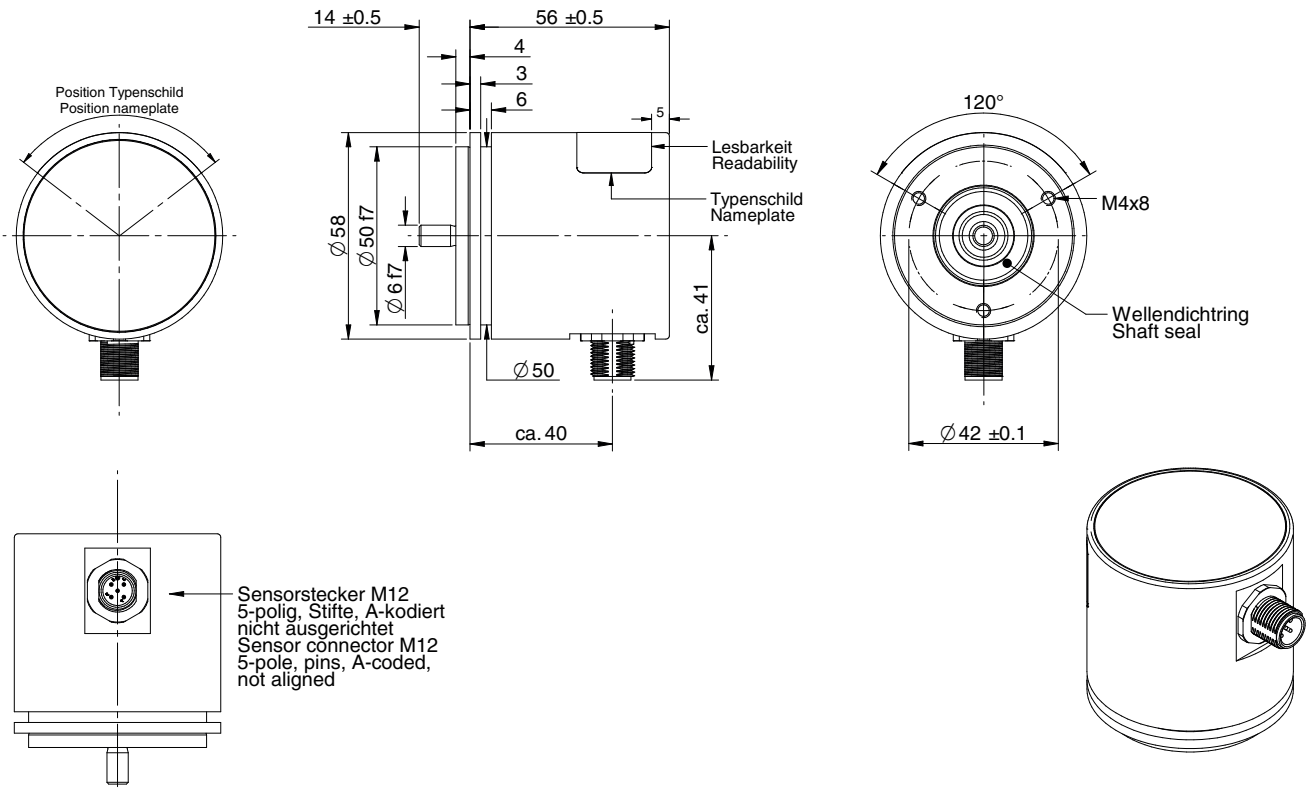

Order identification: **TBN58 - KA 16384 R S4 S1 V1 N01**

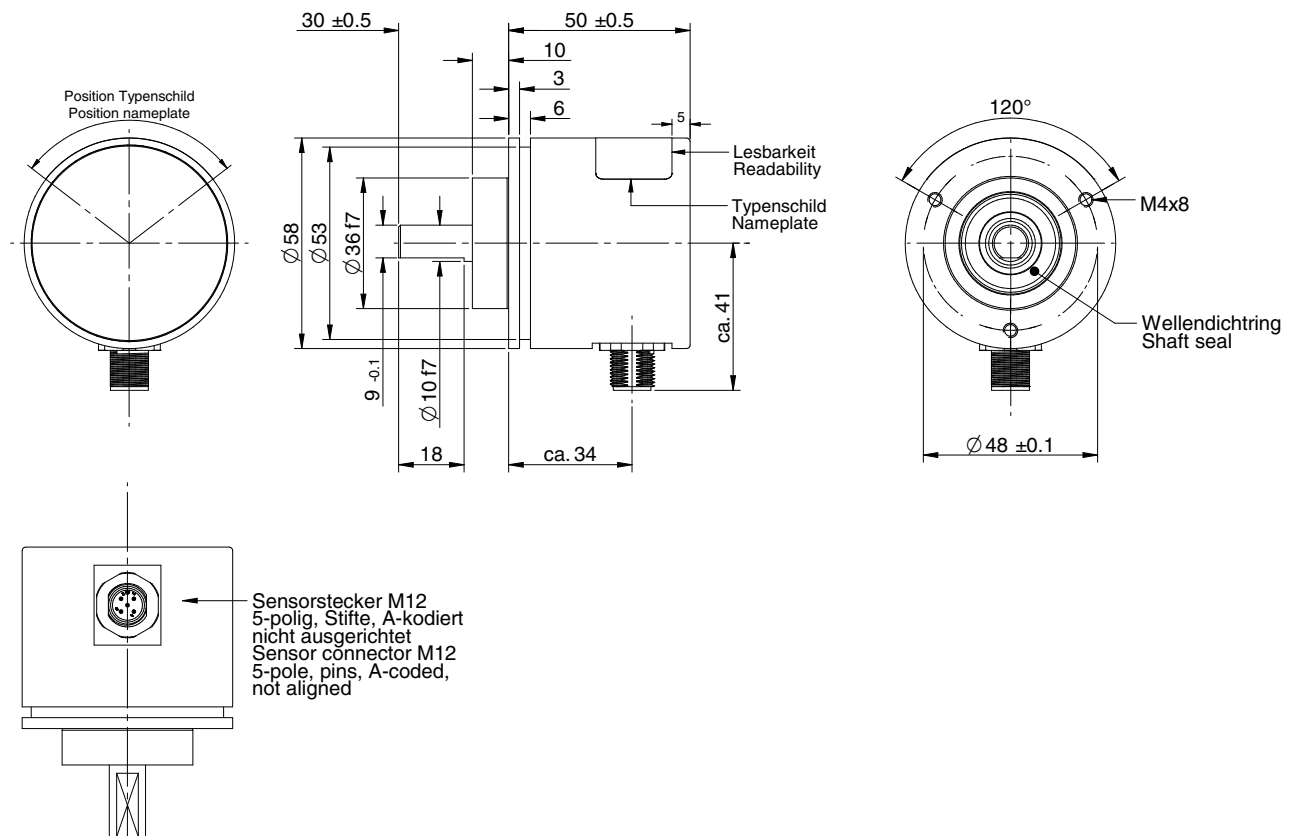

**Absolute Monotour/Multitour shaft encoder
models TBN/TRN with CANopen Safety SIL2 and CANopen**

Installation drawings (dimensions in mm)

Order identification: TRN58 - KA 16384 R 4096 S4 S1 V1 N01

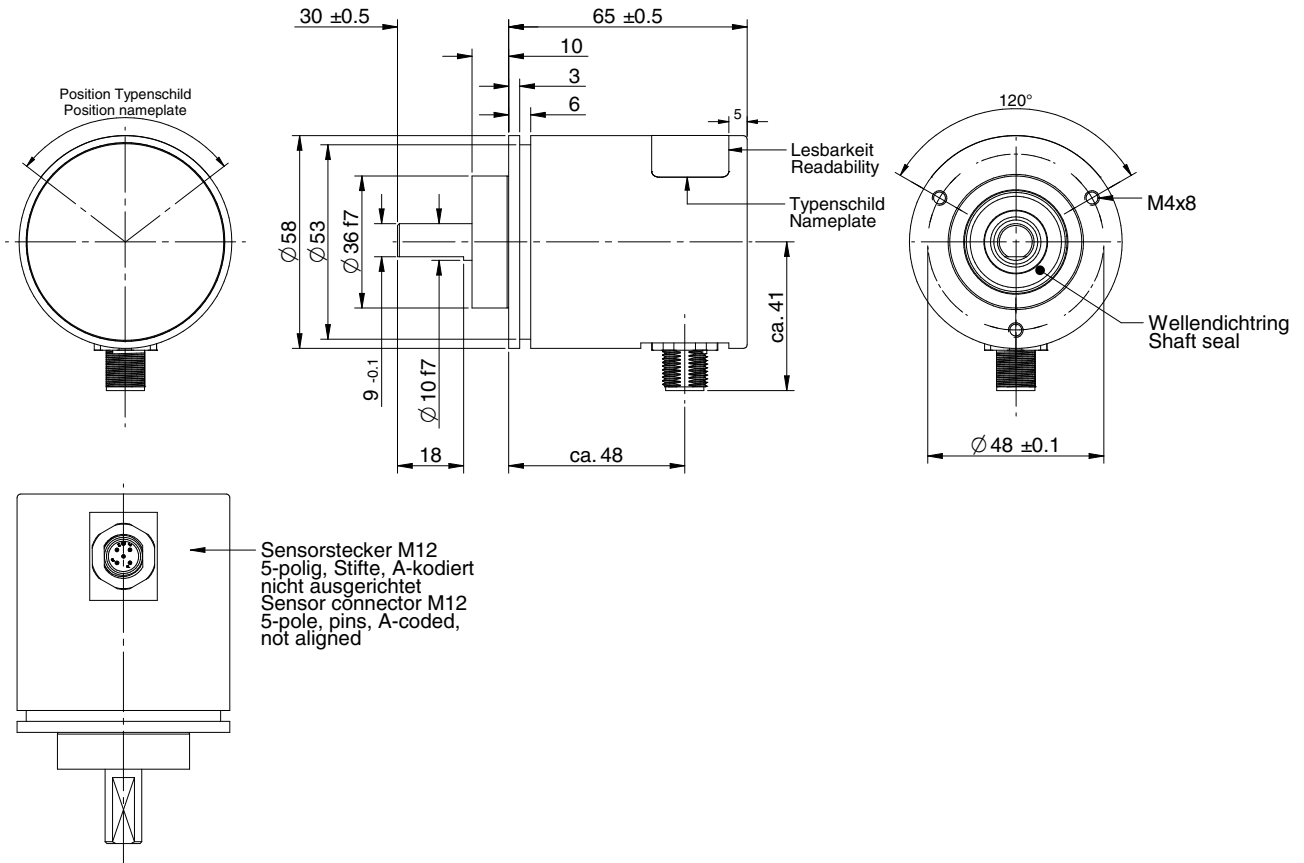

**Absolute Monotour/Multitour shaft encoder
models TBN/TRN with CANopen Safety SIL2 and CANopen**

Installation drawings (dimensions in mm)

Order identification: TBN50 - SA 16384 R C3 S1 V1 N01

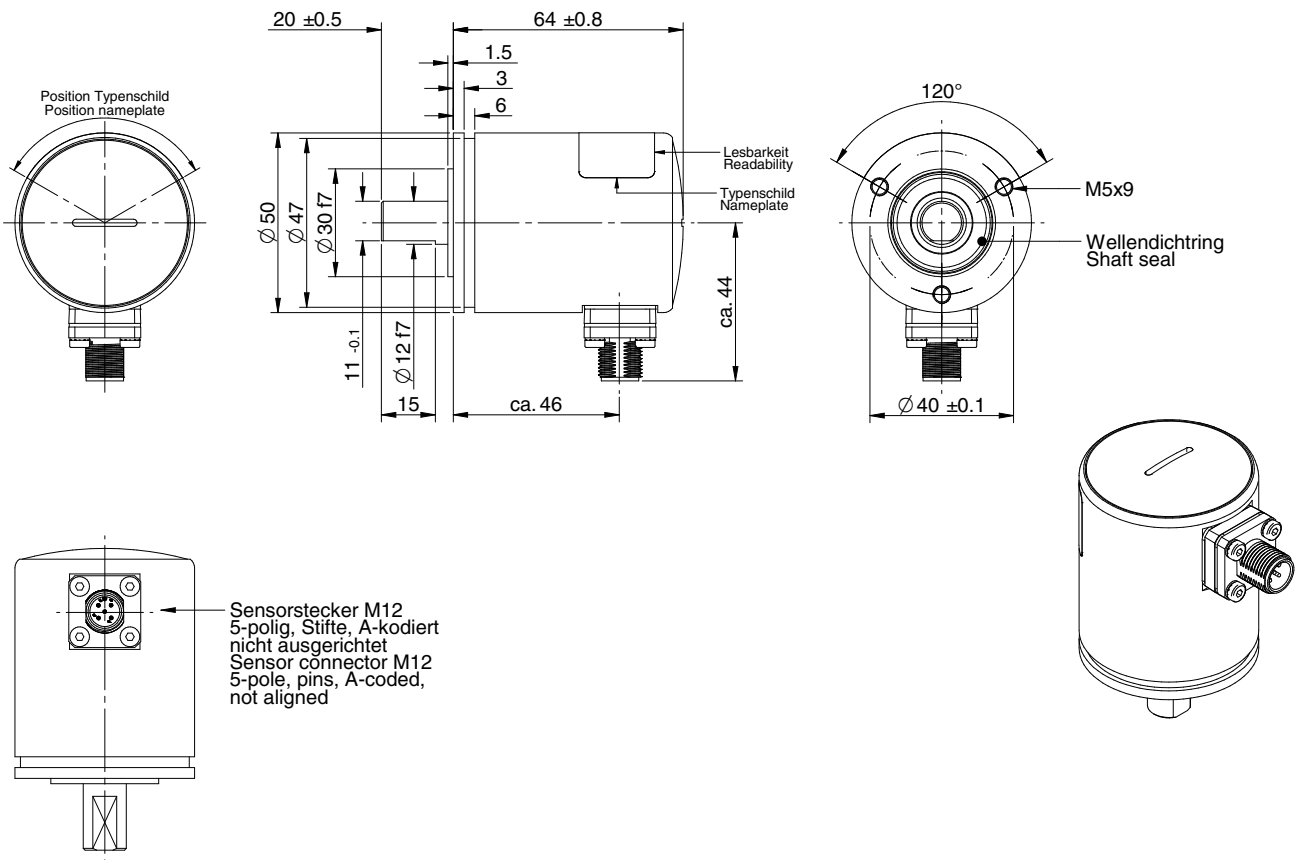

Absolute Monotour/Multitour shaft encoder models TBN/TRN with CANopen Safety SIL2 and CANopen

Installation drawings (dimensions in mm)

Order identification: TBN50 - SA 16384 R S4 S1 V1 N01

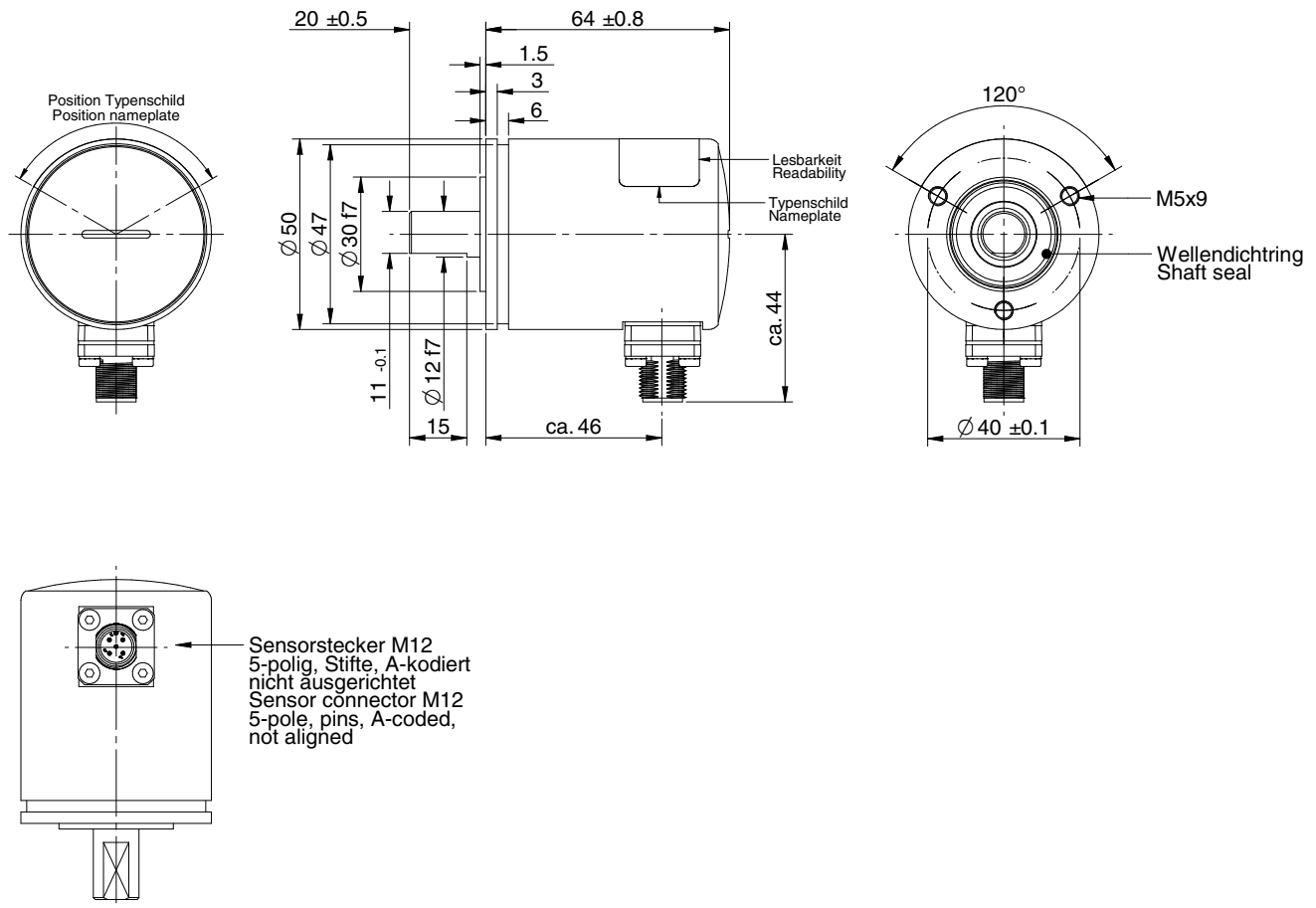

**Absolute Monotour/Multitour shaft encoder
models TBN/TRN with CANopen Safety SIL2 and CANopen**

Installation drawings (dimensions in mm)

Order identification: TRN50 - SA 16384 R 4096 C3 K1 V1 N01

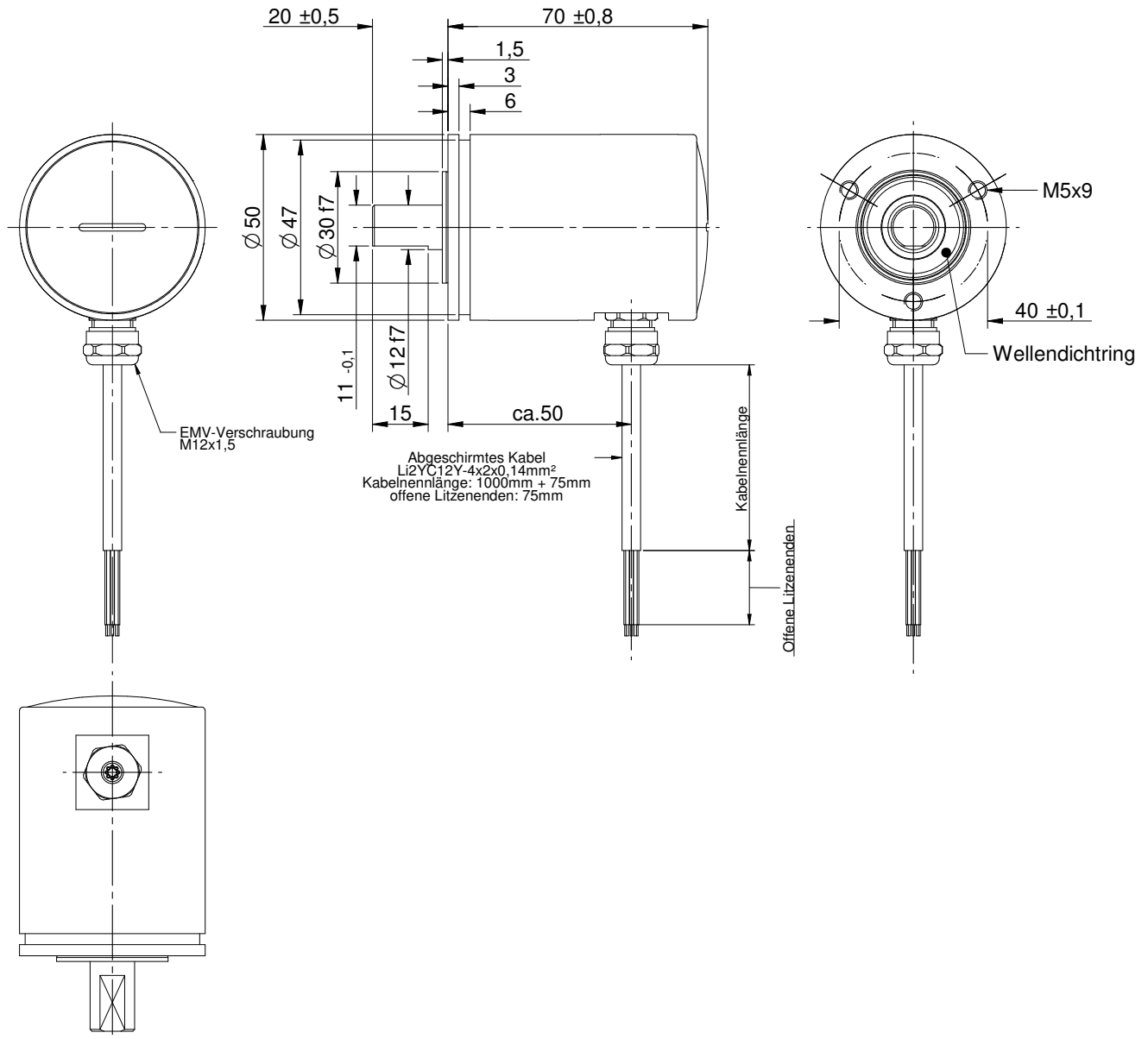

**Absolute Monotour/Multitour shaft encoder
models TBN/TRN with CANopen Safety SIL2 and CANopen**

Installation drawings (dimensions in mm)

Order identification: **TRN42 - SA 16384 R 4096 S4 K1 N01**

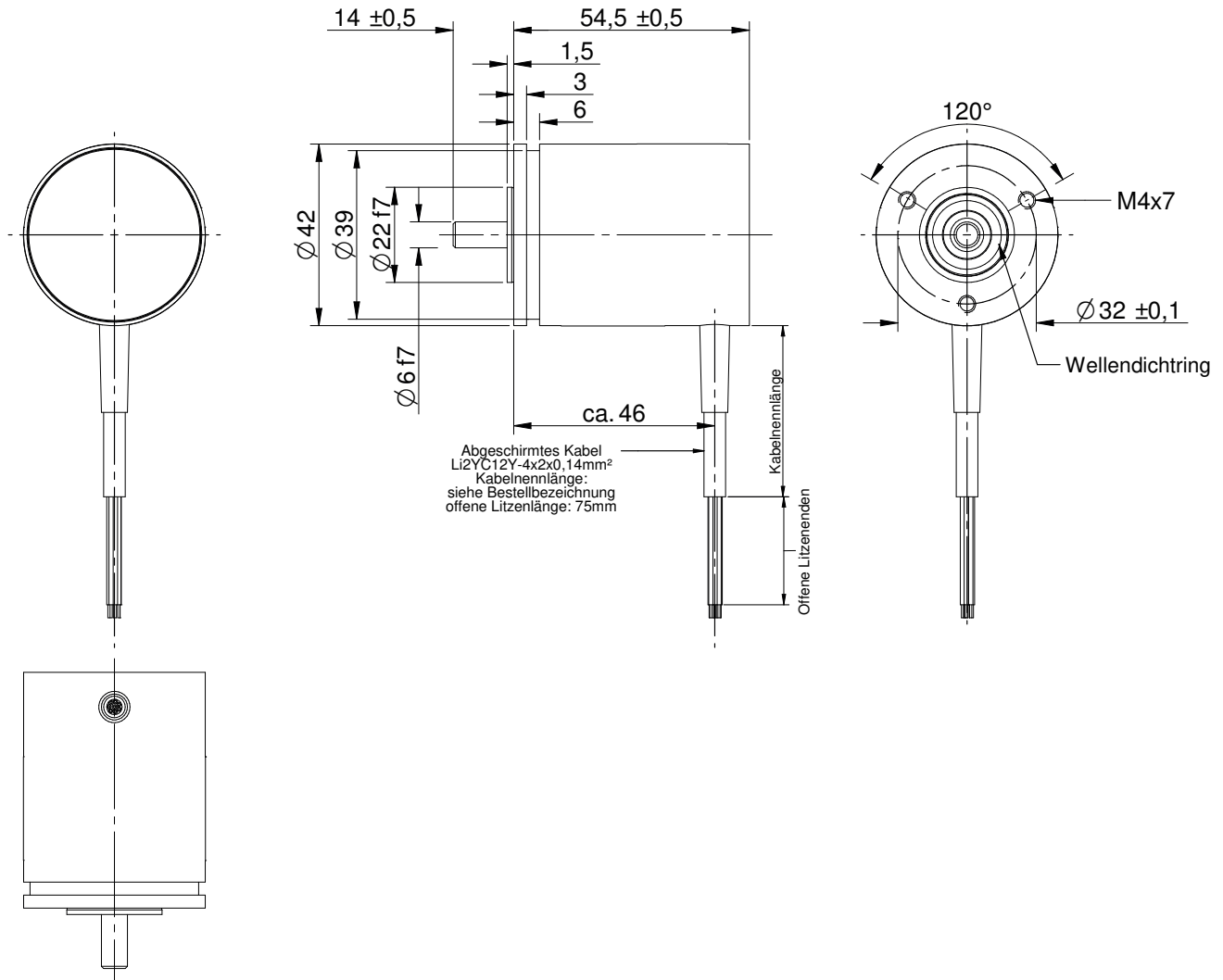

Absolute Monotour/Multitour shaft encoder models TBN/TRN with CANopen Safety SIL2 and CANopen

Installation drawings (dimensions in mm)

Order identification: TRN58 - SRA 16384 R 4096 S4 S1 N01

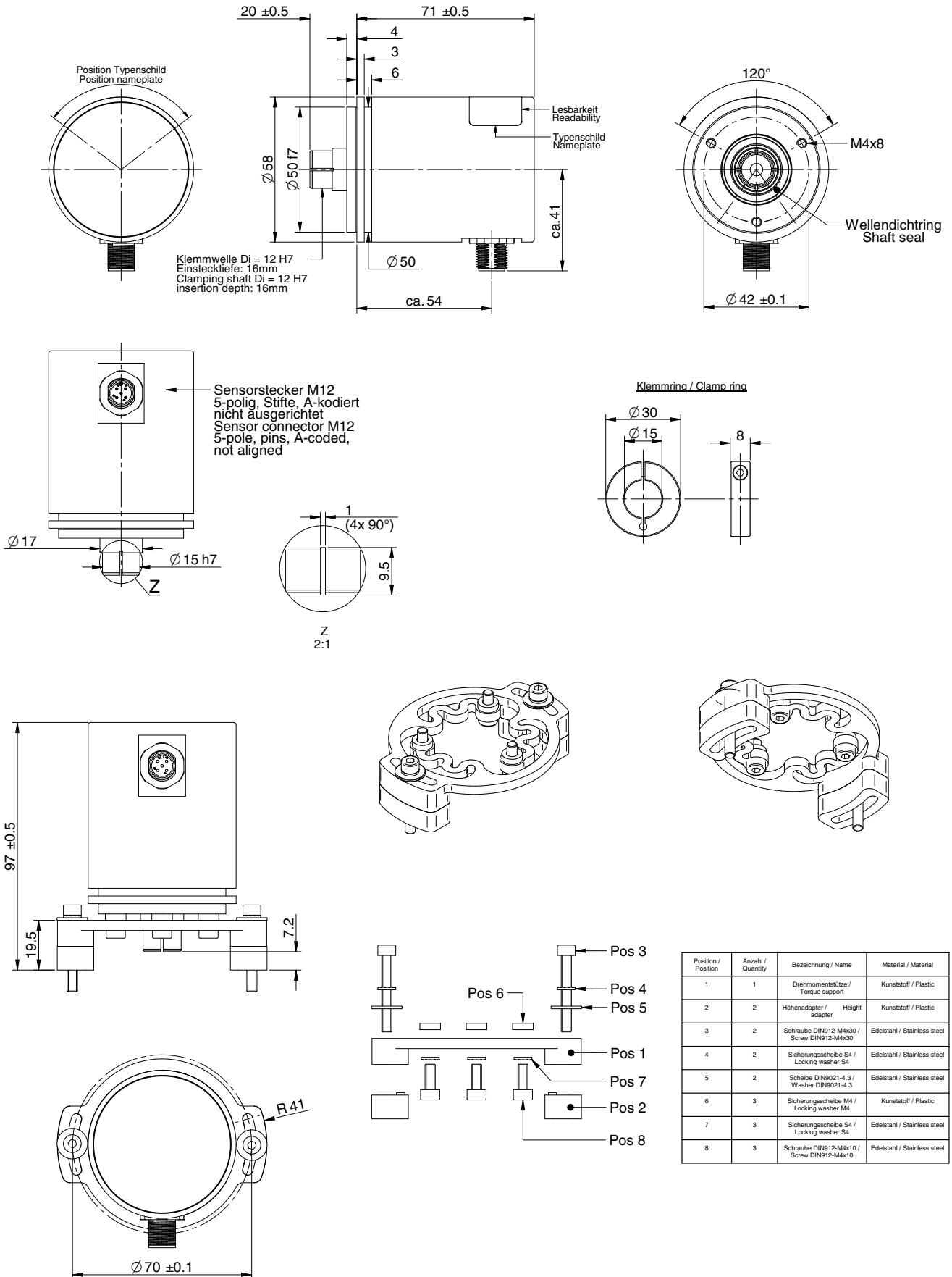

Position / Position	Anzahl / Quantity	Bezeichnung / Name	Material / Material
1	1	Drehmomentstütze / Torque support	Kunststoff / Plastic
2	2	Höhenadapter / Height adapter	Kunststoff / Plastic
3	2	Schraube DIN912-M4x20 / Screw DIN912-M4x20	Edelstahl / Stainless steel
4	2	Sicherungsgeschelbe S4 / Locking washer S4	Edelstahl / Stainless steel
5	2	Scheibe DIN9021-4,3 / Washer DIN9021-4,3	Edelstahl / Stainless steel
6	3	Sicherungsgeschelbe M4 / Locking washer M4	Kunststoff / Plastic
7	3	Sicherungsgeschelbe S4 / Locking washer S4	Edelstahl / Stainless steel
8	3	Schraube DIN912-M4x10 / Screw DIN912-M4x10	Edelstahl / Stainless steel

Absolute Monotour/Multitour shaft encoder models TBN/TRN with CANopen Safety SIL2 and CANopen

Installation drawings (dimensions in mm)

Order identification: TBN58 - SRA 16384 R 4096 S4 S1 N01

