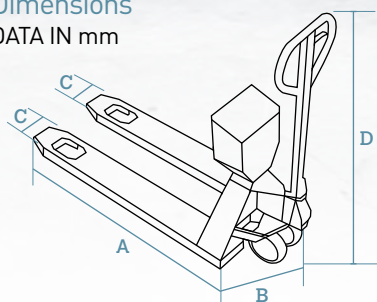
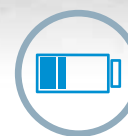

TP

Dimensions
DATA IN mm

A	1,160
B	688
C	244
D	1,212

LCD
SEGMENT
DISPLAY4 LOAD
CELLSINTERNAL
RECHARGEABLE
BATTERY

Specifications

Main characteristics

- Weighing forklift for intensive use in warehouse.
- 4 load cells.
- Backlit LCD segment display, with 5 ½ digits (52 mm).
- Powered by means of an internal rechargeable battery.

Construction

- Structure:
 - › Painted steel.
- 4 steel load cells (IP68).
- Polyurethane coated steel wheels.

Power supply

- External AC adaptor (9 V / 800 mA).
- Internal rechargeable battery 6 V / 10 Ah.

Functions

- Units change: kg/lb.
- Gross weight / net weight.
- Accumulation.
- Zero.
- Tare.

Model

RANGE 2,000 kg (2,000 divisions)

TW

Ref.: 71A000TW012S__