

Pin Type	Interface Dim L	Pin Type	REV	MODIFICATION	DATE	DRAW
Detect	3.5 mm	25,26	E	EN-04-0424	2004/04/16	TONY
General	4.25 mm	All Other Pins	F	EN-07-0906	2007/09/11	SAN
Power	5.0 mm	1,13,38,50	G	EN-10-0418	2010/04/09	TONY

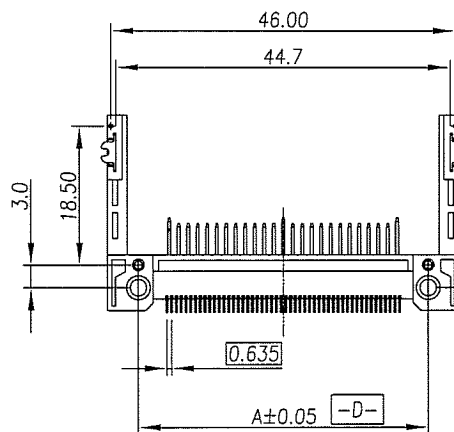
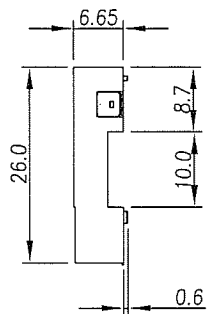
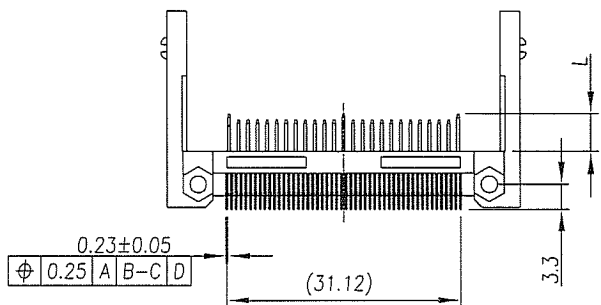
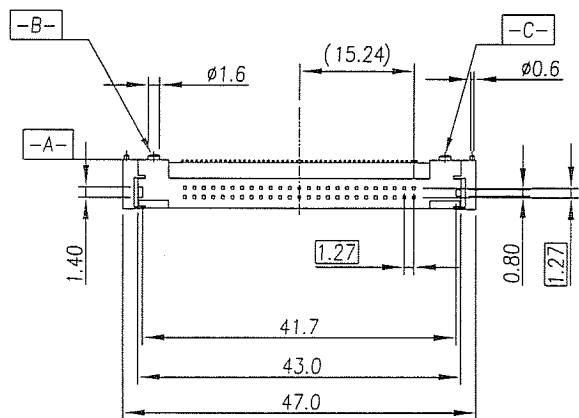

Ordering Information:

CFC M D - 4 5 X XX W 1 1 X
 TYPE 2(SLIM)
 Pin No. 50 Position
 Color: W-White.
 Dim-A 0-38.74 1-40.16

T : COMPLY TO SONY SS-00259

Contact Area Plating:
 01--G/F Gold Plating.
 05--5u" Gold Plating.
 15--15u" Gold Plating.
 30--30u" Gold Plating.

1 : REVERSE TYPE
 1:STANDOFF 2.0mm

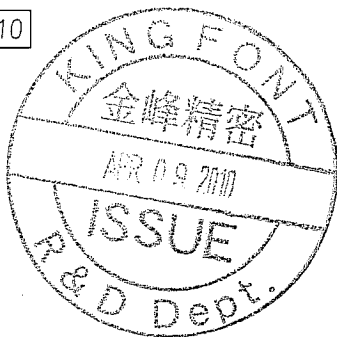
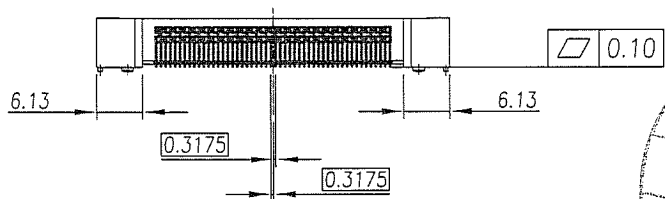

DIMENSION IN mm [Inch]		PROD. SPEC. SPO028	KINGFONT PRECISION INDUSTRIAL CO., LTD.	
TOLERANCE UNLESS OTHERWISE SPECIFIED		PKG. SPEC. PPP-CFC-006	CF CARD CONN. TYPE 1,2 STAND-OFF 2.0mm REVERSE TYPE	CUSTOMER DRAWING
.X±0.30	X.*± 1*	APPROVE <i>Gomy</i>	FILE NO. KFP-028	DWG NO. CFCMD-45XXXW11X
.XX±0.20	.X.*± 0.5*	CHECK <i>3ts</i>	SIZE A4	PROJ. SHEET 1 / 2
.XXX±0.10	.XX.*± 0.25*	DRAW <i>Fory</i>	SCALE 1:1	REV G

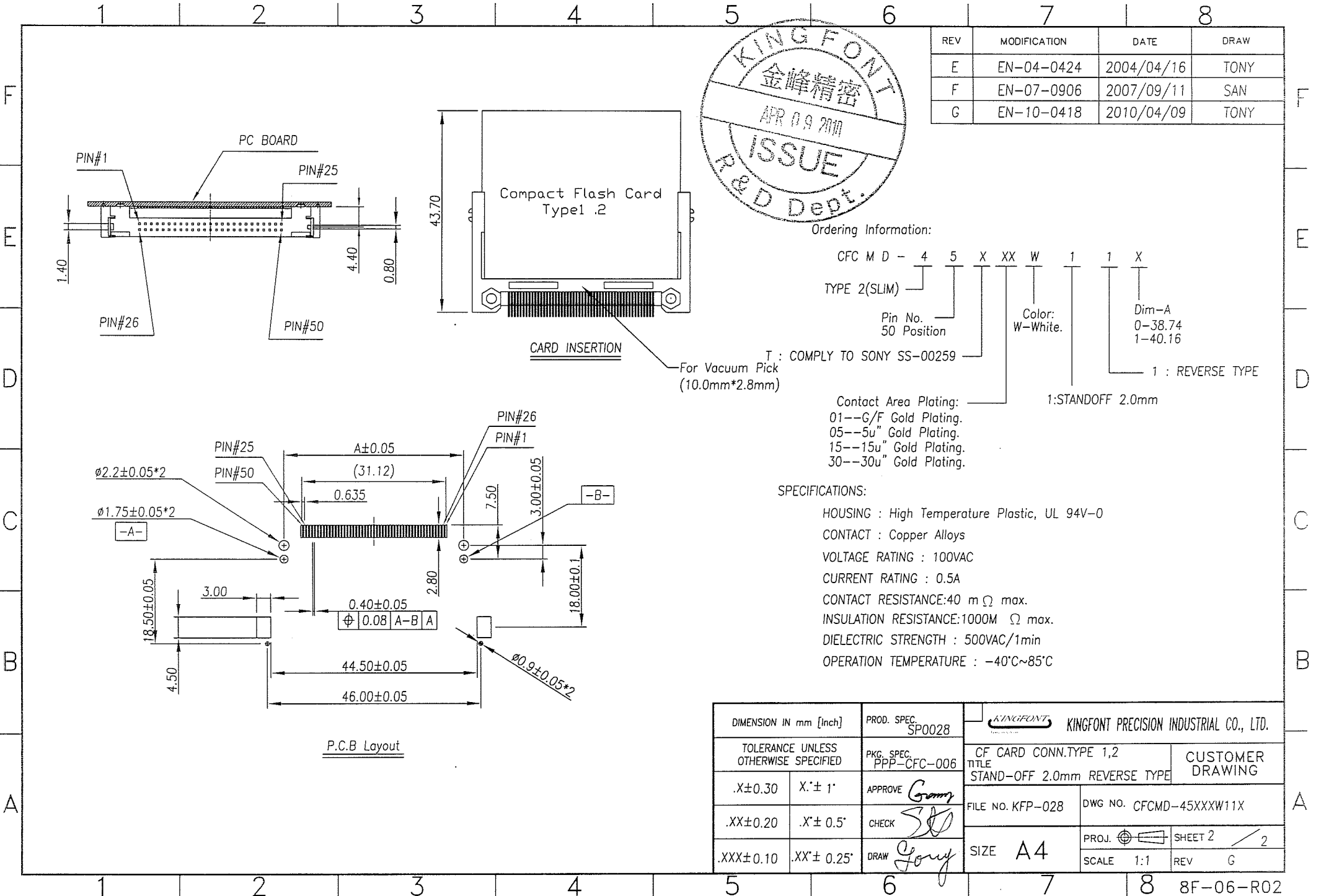

REV	MODIFICATION	DATE	DRAW
E	EN-04-0424	2004/04/16	TONY
F	EN-07-0906	2007/09/11	SAN
G	EN-10-0418	2010/04/09	TONY



Ordering Information:

CFC M D - 4 5 X XX W 1 1 X

TYPE 2(SLIM)

Pin No. 50 Position

Color: W-White.

Dim-A
0-38.74
1-40.16

1 : REVERSE TYPE

1:STANDOFF 2.0mm

Contact Area Plating:
 01--G/F Gold Plating.
 05--5u" Gold Plating.
 15--15u" Gold Plating.
 30--30u" Gold Plating.

SPECIFICATIONS:

HOUSING : High Temperature Plastic, UL 94V-0

CONTACT : Copper Alloys

VOLTAGE RATING : 100VAC

CURRENT RATING : 0.5A

CONTACT RESISTANCE:40 mΩ max.

INSULATION RESISTANCE:1000M Ω max.

DIELECTRIC STRENGTH : 500VAC/1min

OPERATION TEMPERATURE : -40°C~85°C

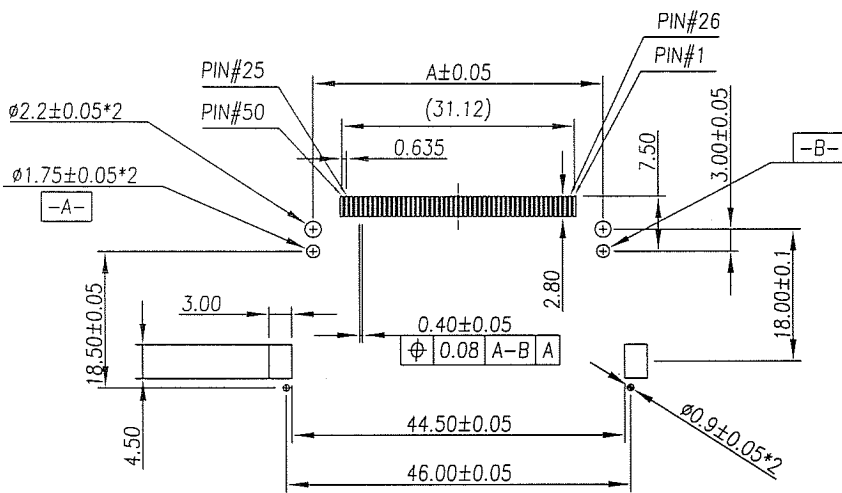

P.C.B Layout

DIMENSION IN mm [Inch]		PROD. SPEC. SPO028	KINGFRONT KINGFONT PRECISION INDUSTRIAL CO., LTD.	
TOLERANCE UNLESS OTHERWISE SPECIFIED		PKG. SPEC. PPP-CFC-006	CF CARD CONN.TYPE 1,2	CUSTOMER DRAWING
.X±0.30	X.*± 1'	APPROVE Gomy	STAND-OFF 2.0mm REVERSE TYPE	
.XX±0.20	.X'± 0.5'	CHECK 30	FILE NO. KFP-028	DWG NO. CFCMD-45XXXW11X
.XXX±0.10	.XX'± 0.25'	DRAW Gomy	SIZE A4	PROJ. SHEET 2 / 2
			SCALE 1:1	REV G