

Top labeling

You want to  
do things right  
instead of accepting  
compromises?



## Top labeling

# The 452E stands for reliability, precision and speed

All these attributes are provided by the machine's generous equipment. Among other things, it offers easy access for adjustments, the innovative HERMA 500, a control system for label presence check and a control panel for managing all formats. With the top labeler 452E you are no longer faced with a choice between labeling precision and speed – it delivers both at the same time.

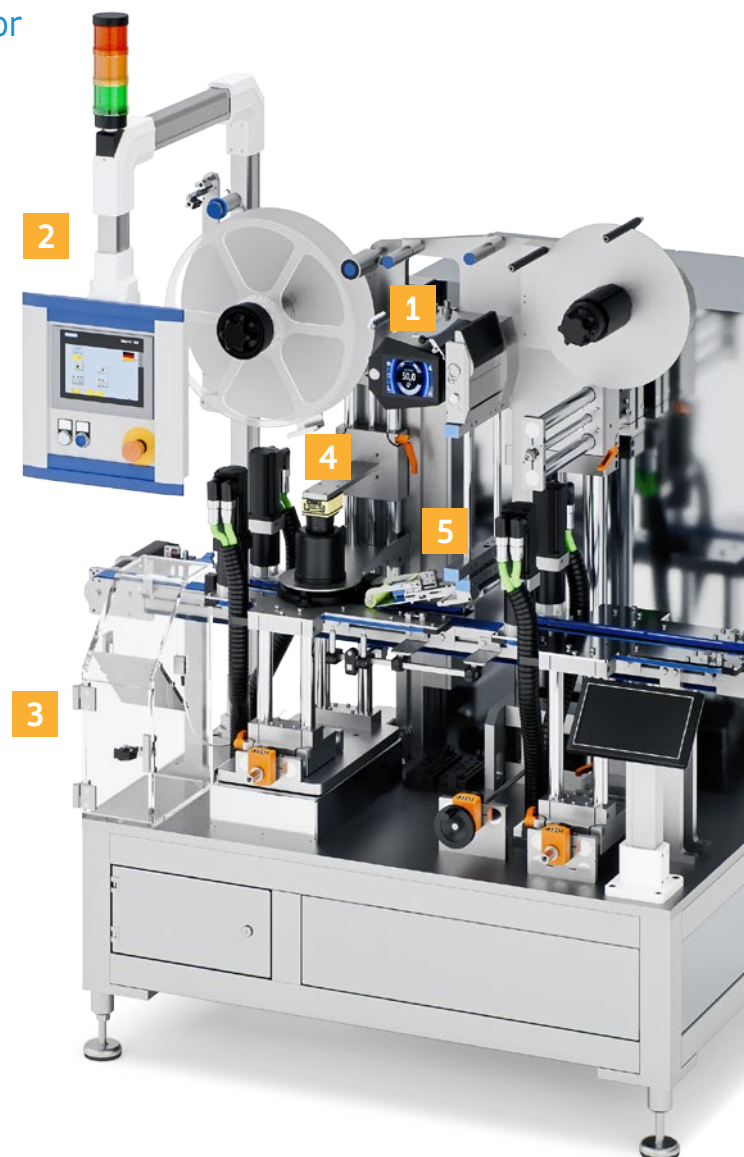

## Best results

Thanks to the integrated HERMA 500, high throughput – even during continuous operation – and absolutely precise label application are guaranteed.

Equipped with a control panel, PLC and intuitive user interface, the operator has all information at a glance at all times.

To ensure that products are not passed down the line without labels, a control system for label presence check detects any that are missing. After the checking station, products with a missing label are re-routed to a reject box by compressed air.



## Useful options

An optional camera system checks both the presence and the position of labels, and uses the captured data to make adjustments for the next labeling. In case of tolerance deviations, machine parameters are adjusted fully automatically as necessary. This ensures that e. g. round labels are placed exactly in the center of round products.

For printing variable data, various hot-foil and thermal transfer printers are easy to integrate.

Various interfaces are available for line integration. For the infeed and outfeed of the conveyor belt optionally motorized transfer belts can be supplied, which ensure a smooth transfer of the products from and to other conveyor belts in the line.

### Technical data

Labeling type:	Top labeling
Product specifications:	Rectangular, cylindrical, free-standing
Product dimensions:	50 x 50 x 15 mm - 100 x 100 x 150 mm (L x W x H)
Label dimensions:	15 - 100 mm x 30 - 100 mm (W x L)
Capacity:	Up to 250 products/minute
Power supply:	400V, TN-C-S, 50 Hz, 3 phases 208 V, delta 4-wire, 60 Hz, 3 phases (optional)
Compressed air supply:	6 bar
Printer:	Various hot-foil and thermal transfer printers (optional)
Components:	Control panel with 7 inch touchscreen, signal column, conveyor belt, side guides for products, applicator with digital position indicators for all adjustments, label presence check, product reject station
Options:	Camera system for checking the label position, self-adjusting system for tracking the label position, print check, code check, transfer belts at the infeed and outfeed end
Note:	If optional features are chosen, the above data may vary

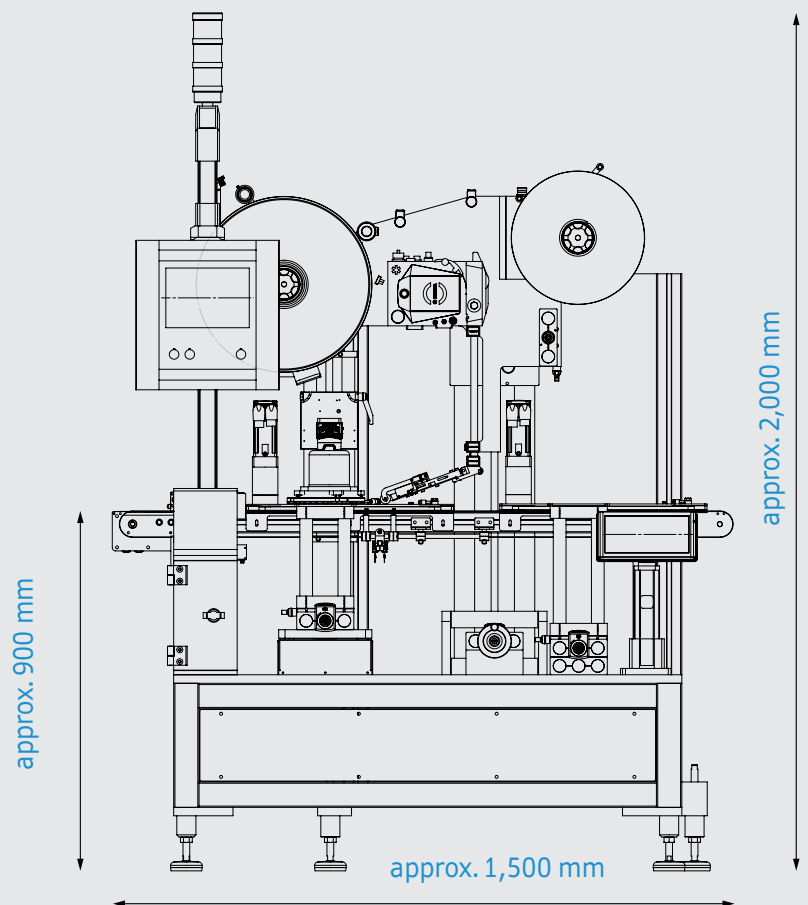

HERMA GmbH  
 Labeling Machines Division  
 Heinrich-Hermann-Straße 14  
 70794 Filderstadt  
 Tel. +49 711 7702-6012  
[www.herma.com/machines](http://www.herma.com/machines)  
[machines@herma.com](mailto:machines@herma.com)



452E Video